



FILTERCHARGER® INJECTION PERFORMANCE KIT

INSTALLATION INSTRUCTIONS

57-1501

Dodge
1992-1996 Dakota
V6-3.9L, V8-5.2L
2 & 4 Wheel Drive

PARTS LIST:

	Description	Qty.	P/N
A	1/4"-20 nylock nut	1	07517
B	Washer	1	08151
C	Rubber washer	1	21708
D	Top plate	1	06842
E	Filtercharger® element	1	E-3742
F	Base plate	1	01545
G	Hose clamp	1	08411
H	Base gasket	1	09988
I	1/4" X 4.5" Bent stud	1	08007

NOTE: FAILURE TO FOLLOW INSTALLATION INSTRUCTIONS AND NOT USING THE PROVIDED HARDWARE MAY DAMAGE THE INTAKE TUBE, THROTTLE BODY AND ENGINE.

INSTALLATION

See the figure above for stock part locations

See the figure on the next page for finished kit locations

- 1) Disconnect the vehicle's negative battery cable.
- 2) Remove the vent hose at stock airbox, then remove the entire airbox along with the intake tube and base gasket.
- 3) Remove and replace the stock stud attached at the throttle-body with the provided 'z' stud.
- 4) Install the new base plate and gasket to the throttle body. (see exploded view on next page)
You will need to cut the stock vent hose and secure it to the fitting. (use supplied hose clamp)
- 5) Install the filter and lid.
- 6) Position for best clearance and tighten all hardware.
- 7) Re-connect battery cable. Double check to make sure everything is tight and properly positioned before starting vehicle.
- 8) The C.A.R.B. exemption sticker, (attached) must be placed in a visible area under the hood so that an emissions inspector can see it when the vehicle is required to be tested for emissions. California requires testing every two years, other states may vary.
- 9) It will be necessary for all FIPK's to be checked periodically for realignment, clearance and tightening of all connections. Failure to follow the above instructions or proper maintenance may void warranty.

ROAD TESTING

1. Start the engine with the transmission in neutral or park, and the parking brake engaged. Listen for air leaks or odd noises for air leaks secure hoses and connections. For odd noises, find cause and repair before proceeding. This kit will function identically to the factory system except for being louder and much more responsive.
2. Test drive the vehicle. Listen for odd noises or rattles and fix as necessary.
3. If road test is fine, you can now enjoy the added power and performance from your kit.
4. K&N suggests checking the Filtercharger element periodically for excessive dirt build-up. When the element becomes covered in dirt (or once a year), service it according to the instructions on the Recharger service kit, part number 99-5050 or 99-5000.

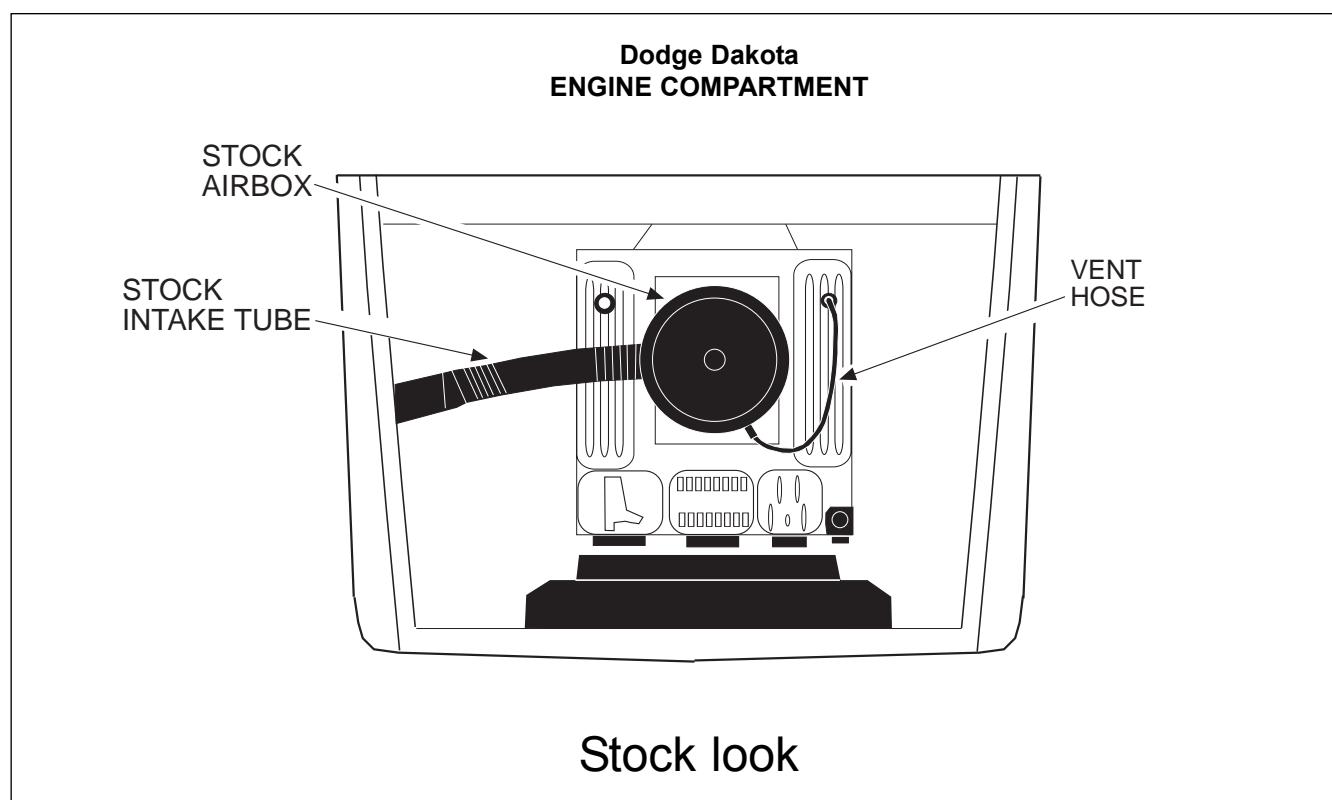
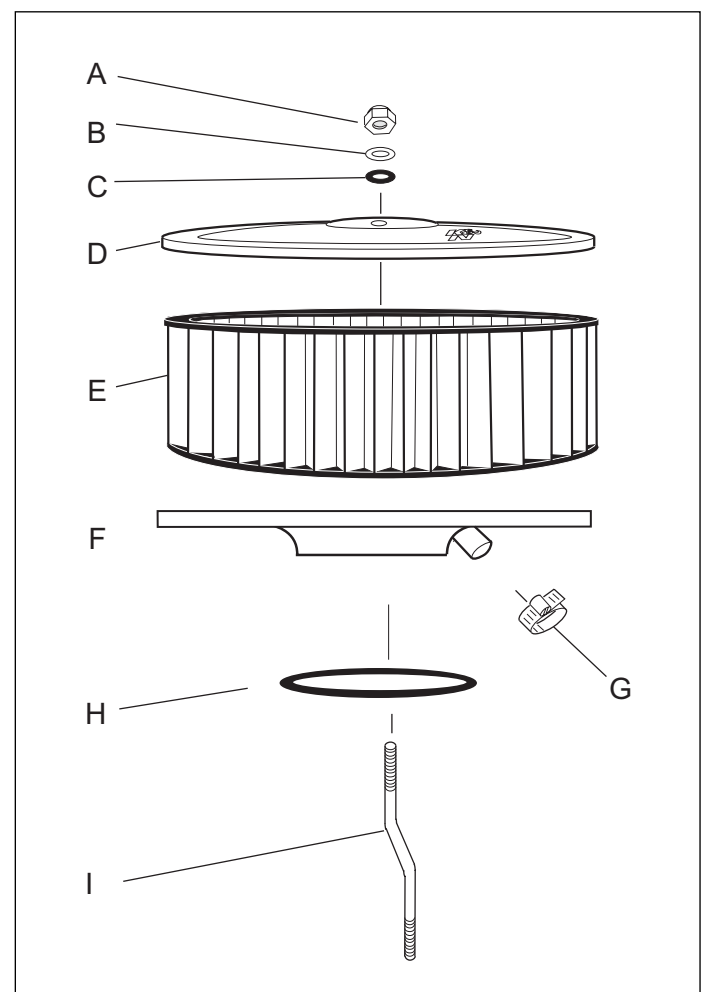

FREE K&N DECAL To register your warranty, please see us online at knfilters.com/register. FREE K&N DECAL

