

It is critical for small tooling to have correct set ups. Speeds and feeds, condition of toolholder, insert and machine, centerline heights, squareness of cutting edge to machine, rigid machine to toolholder relationships are vital for proper performance in all applications. The items listed are general guides, but will not solve all problems. Please call our sales office for additional assistance.

Problem	Things to try
Grooving	
Cutting oversized; Groove walls not square	Check insert squareness; Check toolholder condition; Check insert centerline; Check machine alignment; Decrease IPR
Chatter; Poor finish	Increase speed; Reduce feed; Check toolholder condition; Check centerline; Stub toolholder and review toolholder size and machine set up for maximum rigidity; Add coating; Add top rake
Built up edge; Insert chipping	Increase feed; Increase speed; Run with coolant; Use coated insert; Check insert centerline
Burr on part	Add chamfer to insert; Turn or bore diameter after groove
Insert breaking	Check insert squareness; Check toolholder condition; Check insert centerline; Check machine condition; Decrease IPR; Review speeds and feeds; Verify insert grade
Chip control	Increase feed; Use peck cycle; Mount with cutting edge down; Flood with coolant; Add chip control to insert
Face Grooving	
Cutting oversized; Groove walls not square	Check insert squareness; Check toolholder condition; Check insert centerline; Check machine alignment; Decrease IPR
Chatter; Poor finish	Increase speed; Reduce feed; Check toolholder condition; Check centerline; Stub toolholder and review toolholder size and machine set up for maximum rigidity; Add coating; Add top rake
Built up edge; Insert chipping	Increase feed; Increase speed; Run with coolant; Use coated insert; Check insert centerline
Burr on part	Add chamfer to insert; Turn or bore diameter after groove
Insert breaking	Check insert squareness; Verify clearance diameter; Check insert centerline; Check toolholder condition; Check machine condition; Decrease IPR; Review speeds and feeds; Verify insert grade
Chip control	Increase feed; Use peck cycle; Mount with cutting edge down; Flood with coolant; Add chip control to insert
Boring/Turning	
Chatter; Poor Finish	Increase speed; Reduce feed; Check toolholder condition; Check centerline; Verify chip evacuation; Verify coolant reaching cutting edge; Stub toolholder and review toolholder size and machine set up for maximum rigidity; Add coating; Add top rake
Built up edge; Insert chipping	Increase feed; Increase speed; Increase corner radius; Run with coolant; Use coated insert; Check insert centerline
Insert breaking	Check squareness; Verify clearance diameter; Check centerline; Check toolholder condition; Check machine condition; Decrease IPR; Review speeds and feeds; Verify insert grade
Chip control	Increase feed; Mount with cutting edge down; Flood with coolant; Add chip control to insert
Threading	
Chatter; Poor finish	Increase speed; Reduce depth of cut per pass; Check toolholder condition; Check centerline; Verify chip evacuation; Verify coolant reaching cutting edge; Stub toolholder and review toolholder size and machine set up for maximum rigidity; Add coating
Built up edge; Insert chipping	Increase depth of cut per pass; Increase speed; Increase corner radius; Run with coolant; Use coated insert; Check insert centerline
Insert breaking	Check squareness; Check centerline; Check toolholder condition; Check machine condition; Decrease depth of cut per pass; Review speeds and feeds; Verify insert grade
Parting	
Insert leading; Faces not square	Check insert squareness; Check toolholder condition; Check insert centerline; Check machine alignment; Decrease IPR; Add lead angle
Chatter; Poor finish	Increase speed; Reduce feed; Check toolholder condition; Check centerline; Stub toolholder and review toolholder size and machine set up for maximum rigidity; Add coating; Add top rake
Built up edge; Insert chipping	Increase feed; Increase speed; Run with coolant; Use coated insert; Check insert centerline
Burr on part	Chamfer before parting; Add lead angle to drop side of insert
Insert breaking	Check insert squareness; Check toolholder condition; Check insert centerline; Check machine condition; Decrease IPR; Review speeds and feeds; Verify insert grade
Chip control	Increase feed; Use peck cycle; Mount with cutting edge down; Flood with coolant; Add chip control to insert

KAISER TOOL COMPANY, INC.

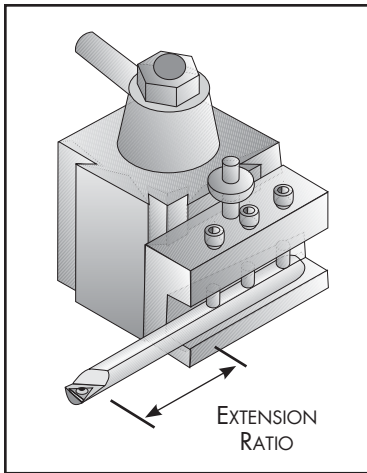

Extension Ratios					
Bar Diameter	Steel 4 x ø	Heavy Metal 6 x ø	Carbide 8 x ø	Shank Height	Steel
.156"	.625"	.937"	1.250"	.312"	1.250"
.187"	.750"	1.125"	1.500"	.375"	1.500"
.250"	1.000"	1.500"	2.000"	.500"	2.000"
.312"	1.250"	1.875"	2.500"	.625"	2.500"
.375"	1.500"	2.250"	3.000"	.750"	2.500"
.500"	2.000"	3.000"	4.000"	1.000"	2.500"
.625"	2.500"	3.750"	5.000"	1.250"	2.500"
.750"	3.000"				
1.000"	4.000"				

Extending a toolholder beyond these recommendations can cause excessive deflection which will result in poor surface finish and reduced insert life. These recommendations may need to be reduced if cutting materials with low machinability, taking heavy cuts or using the tooling in non-rigid machine set-ups.

Toolholder Notes:

- To avoid burrs on your shanks, use only dog point screws. The use of cup point screws promotes burrs on the shanks and can result in problems removing or re-installing bars.
- Complete toolholders may be an assembly of several components each having an individual part number.
- Heavy Metal is a high density Tungsten based alloy that is very tough, stiff and vibration resistant.

INTERNAL TOOL & FACE GROOVING CUTTING HEIGHTS

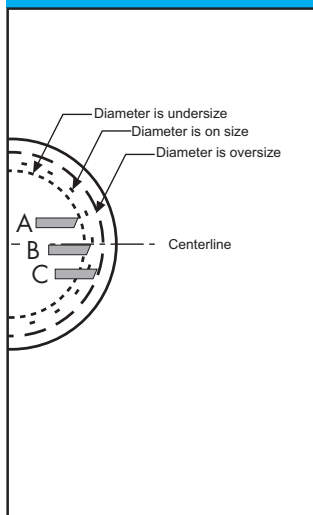

- Normal cutting forces cause tool deflection, therefore internal tools are manufactured to cut .002" to .010" above centerline.
- Setting tool above 'A' will cause diameter to be under desired size.
- Setting tool to cut at 'A' will cause insert to deflect to 'B' and cut desired diameter.
- Setting tool below 'A' will cause insert to deflect to 'C' and cause diameter to be oversized.
- Keep in mind if tools are mounted cutting edge toward floor, above center is toward floor.

EXTERNAL TOOL CUTTING HEIGHTS

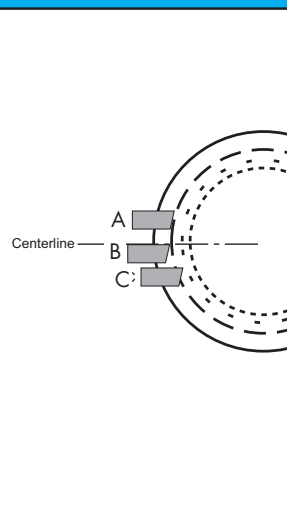

- External tools are manufactured to cut on center to .005" below centerline.
- Setting tool to cut at 'A' can cause heel of insert to rub or cause failure.
- Setting tool to cut at 'B' will cause insert to deflect slightly and cut at 'C'.
- Setting tool below 'C' can cause insert to grab or fail.
- Keep in mind if tools are mounted cutting edge toward floor, below center is toward ceiling.

DEEPCROOVE® Head and Shank Compatibility Chart

Shank	Package	Page	Head	Clamp	Shank	Package	Page	Head	Clamp	Shank	Package	Page	Head	Clamp
DGS__XL	C	2-16	DGH4	DGC2	DGS__XR	B	2-16	DGH3	DGC1	DGS__ZR	N	2-8	DGH6	DGC6
	E	1-14	DGH2	DGC2		F	1-14	DGH1	DGC1		O	7-13	DGH3	DGC1
	S	7-14	DGH5	DGC5		T	7-14	DGH6	DGC6		Q	7-13	DGH1	DGC1
DGS__YR	D	2-16	DGH4	DGC2	DGS__YL	A	2-16	DGH3	DGC1	DGS__ZL	M	2-8	DGH5	DGC5
	G	1-14	DGH2	DGC2		H	1-14	DGH1	DGC1		P	7-13	DGH4	DGC2
	U	7-14	DGH5	DGC5		V	7-14	DGH6	DGC6		R	7-13	DGH2	DGC2

TROUBLE SHOOTING & TOOLHOLDERS

KAISER TOOL COMPANY, INC.