









# A ASSEMBLY INSTRUCTION

No	Part list ( for 2 Chair )	Qty
A	Hoop	2pcs
B	Seat	2pcs
C	Leg frame With sticker left (FL) and Sticker Right (FR)	4pcs
D	Long Spindle	4pcs
E	Medium Spindle	4pcs
F	Short Spindle	4pcs
G	Crossbar	2pcs

No	HARDWARE LIST ( For 2chair)	Qty
H	 M6 x 60 JCBC Screw	8 pcs
I	 1/4 x 1.2 Flat Washer	16 pcs
J	 M6 Spring Washer	16 pcs
K	 M6 x 13 JRN Nut	8 pcs
L	 M4 x 58 Allen key	1 pcs
M	 Wood Burton	8 pcs
N	 M4 x 30 JCBC Screw	12 pcs
O	 M6 x 35 JCBC Screw	12 pcs

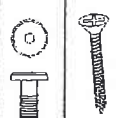

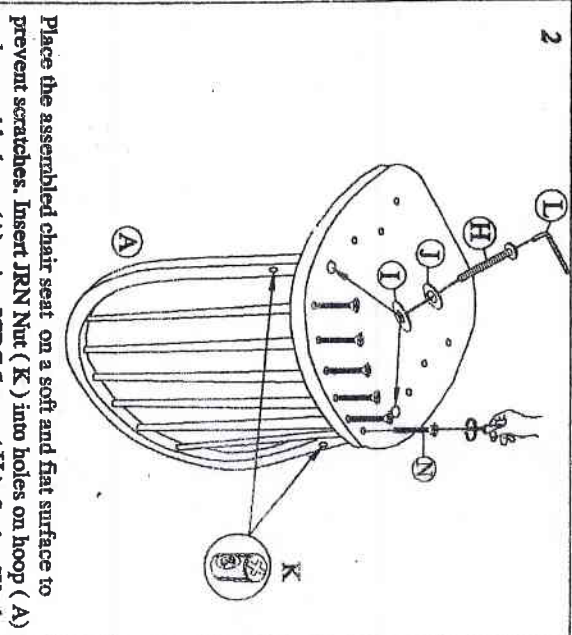
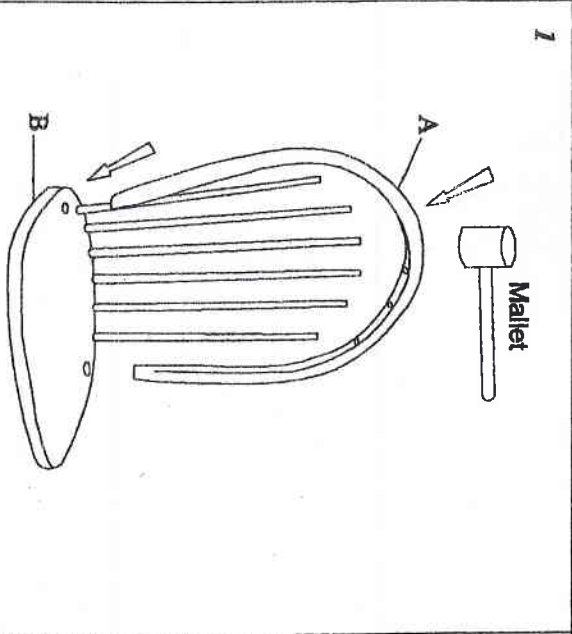
Fix the Spindles (D),(E) & (F) to the Hoop (A) & seat (B), use a mallet to knock the spindles fit in the holes

Place the assembled chair seat on a soft and flat surface to prevent scratches. Insert JRN Nut ( K ) into holes on hoop ( A ) and assemble hoop (A) using JCBC Screw ( H ), Spring Washer (J) and Flat Washer ( I ) in line with JRN Nut ( K ). Please tighten JCBC Screw ( H ) With Allen Key ( L ), then assemble spindles ( D ), ( E ), ( F ) with chair seat by JCBC screw ( N )

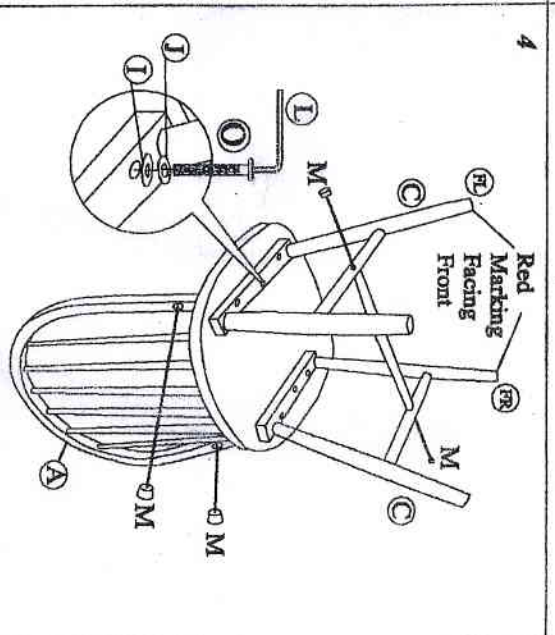
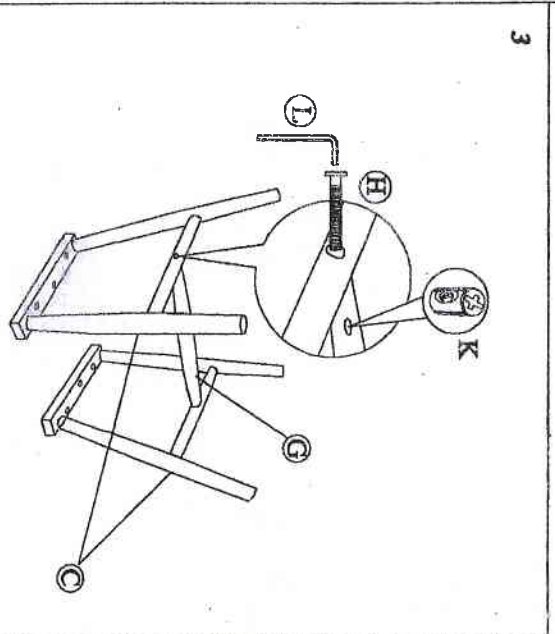

Assemble leg frame ( C ) and Crossbar ( G ) together by insert the JRN Nut ( K ) in the Crossbar ( G ), Secure using JCBC Screw ( H ) as shown.

Attach the Leg Frame ( C ) to the Chair Seat ( B ). Red Marking on leg frame should facing front. Secure it using JCBC ( O ) Spring washer ( J ) and Flat washer ( I ) Tighten it with Allen key ( L ). Insert the Wood Burton ( M ) to the cover the hole on leg frame ( C ) & Hoop ( A )