

Hamilton Beach®

Stand Mixer

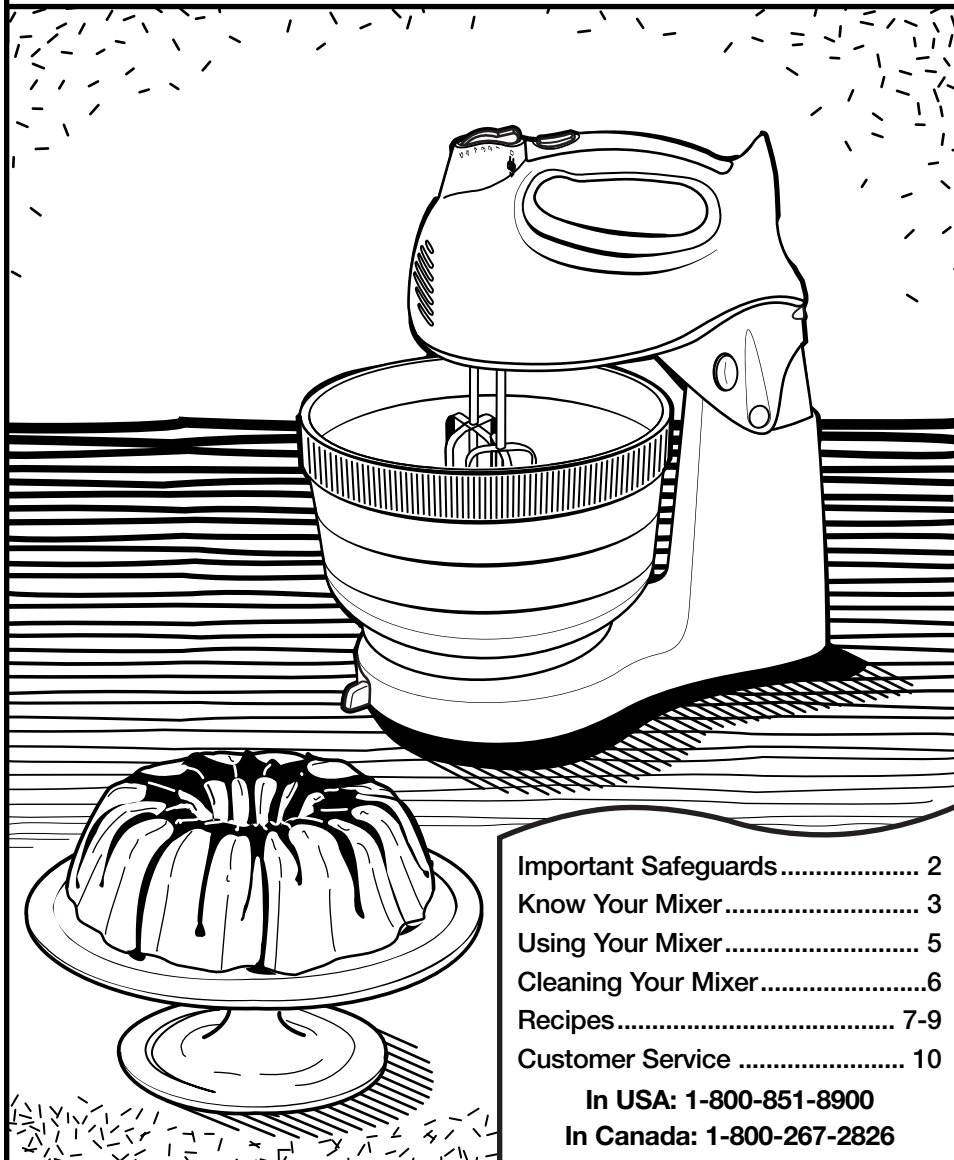

Important Safeguards	2
Know Your Mixer	3
Using Your Mixer	5
Cleaning Your Mixer	6
Recipes	7-9
Customer Service	10

In USA: 1-800-851-8900
In Canada: 1-800-267-2826

IMPORTANT SAFEGUARDS

When using electric appliances, basic safety precautions should always be followed, including the following:

1. Read all instructions.
2. To protect against risk of electrical shock, do not put cord, plug, or mixer body in water or other liquid.
3. Close supervision is necessary when any appliance is used by or near children.
4. Unplug from outlet when not in use, before putting on or taking off parts, and before cleaning.
5. Avoid contacting moving parts. Keep hands, hair, and clothing, as well as spatulas and other utensils, away from beaters during operation to reduce risk of injury to persons, and/or damage to mixer.
6. Remove beaters from mixer before washing.
7. Do not let cord hang over edge of table or counter, or touch hot surfaces, including stove.
8. Do not operate any appliance with a damaged cord or plug, or after the appliance malfunctions or is dropped or damaged in any manner. Call our toll-free customer service number for information on examination, electrical repair, mechanical repair, or adjustment.
9. The use of attachments not recommended or sold by Hamilton Beach/Proctor-Silex, Inc. for use with this model may cause fire, electric shock or injury.
10. Do not use outdoors.
11. Do not place on or near a hot gas or electric burner, or in a heated oven.
12. Check that control is off before plugging cord into wall outlet. To disconnect, turn control to OFF, then remove plug from wall outlet.
13. Do not use appliance for other than intended purpose.

SAVE THESE INSTRUCTIONS

Consumer Safety Information

This appliance is intended for household use only.

This appliance is equipped with a polarized plug. This type of plug has one blade wider than the other. The plug will fit into an electrical outlet only one way. This is a safety feature intended to help reduce the risk of electrical shock. If you are unable to insert the plug into the outlet, try reversing the plug. If the plug should still fail to fit,

contact a qualified electrician to replace the obsolete outlet. Do not attempt to defeat the safety purpose of the polarized plug by modifying the plug in any way.

WARNING: To reduce risk of personal injury, always unplug mixer before inserting or removing beaters.

BEFORE FIRST USE: Wash bowl and beaters in hot, soapy water. Rinse and dry.

CAUTION: Never place mixing bowl in an oven, microwave oven, or on a hot cooking surface. The mixing bowl is not intended to be used at high temperatures and should never be used as cookware, ovenware, or bakeware.

Mixing Tips

Cookie dough is one of the thickest doughs to mix. Make it easier by following these tips:

- Use a large mixing bowl, like the one provided, to spread out ingredients for easier mixing.
- Have butter or margarine at room temperature.
- Add ingredients one at a time, thoroughly mixing after each addition.
- Add flour one cup at a time.
- If adding chips or nuts to a very thick dough or batter, we recommend stirring them in by hand at the very end of the recipe.

Know Your Mixer

Parts and Features

1. Speed Control (On/Off) and Eject
2. Beaters
3. Bowl
4. Turntable
5. Shift and Stir™ Bowl Lever
6. Power Burst
7. Mixer
8. Hand Mixer Release Button
9. Mixer Lockdown Button
10. Stand

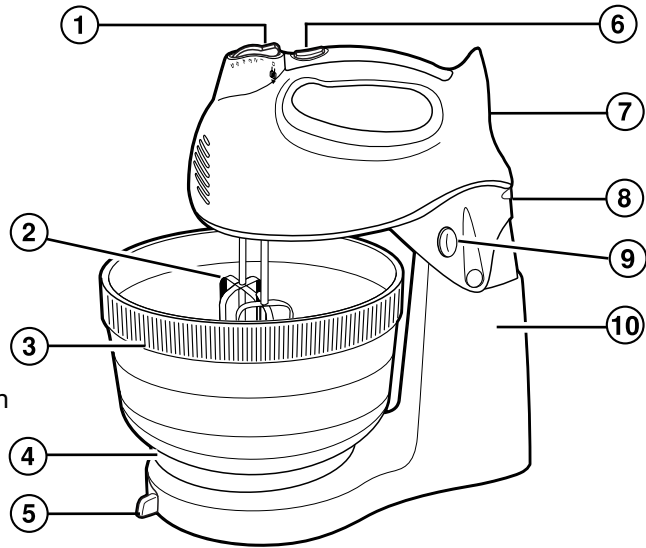

How to Assemble Stand

The stand mixer is very convenient for most recipes. However, small amounts—like one cup of cream—may not contact the beaters in the stand mixer mode. In these cases we recommend using as a hand mixer.

NOTE: Attach mixer to stand before attaching mixing shield, beaters, or other attachments.

1. Set stand on counter and put turntable onto stand. With platform level and while holding mixer as shown, place L-shaped tab on platform into slot on bottom of mixer, as illustrated.

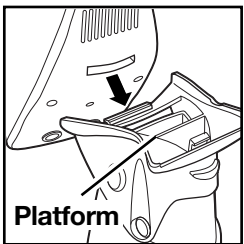

2. As the mixer is lowered, gently press the back of the mixer onto the platform until it locks in position.

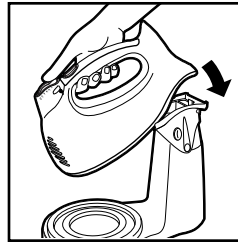

3. The mixer can now be used as a stand mixer.

Optional Attachments (Available on selected models)

Before first use: wash beaters or attachments in warm, sudsy water; rinse and dry. Always unplug mixer from electrical outlet before inserting or removing attachments. This mixer comes with 1 or more of the following attachments:

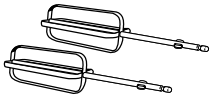
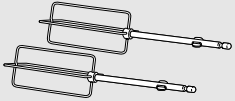
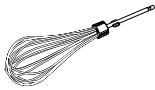
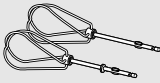
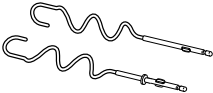
ATTACHMENT	DESCRIPTION
	The flat beaters are designed for general mixing purposes.
	The straight wire beaters , which have no center post for ease in cleaning, are designed for mixing thick batters and cookie dough.
	The single whisk is perfect for whipping cream. The whisk may be inserted into either opening.
	The twisted wire beaters , which have no center post for ease in cleaning, are designed for mixing thick batters and cookie dough.
	The dough hooks can perfectly knead a one loaf bread recipe. Always use dough hooks on speed 4, 5, or 6 in the hand mixer mode. Do not use dough hooks in the stand mixer mode.

To Insert Attachments

Flat Beaters, Straight Wire Beaters, and Whisk

1. Always make sure mixer is unplugged and speed control is set to OFF.
2. Insert a beater or attachment into an opening on the bottom of the mixer. Push until it clicks into place. Repeat with other beater or attachment.

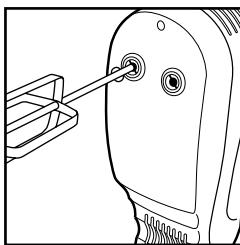

Repeat with other beater or attachment.

Twisted Wire Beaters and Dough Hooks

1. Always make sure mixer is unplugged and speed control is set to OFF.

2. Insert the wire beater or the dough hook with the collar into the opening indicated by the illustration on the mixer.

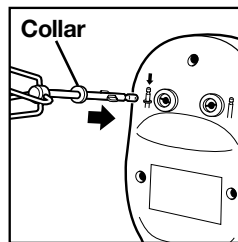

3. Align tabs on the beater or dough hook with the slots in the opening. Push until it clicks into place. Repeat with other beater or dough hook.

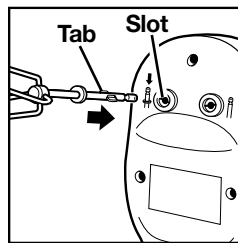

Optional Features (Available on selected models)

Mixing Shield

- To attach:** Place small tabs on the mixing shield into grooves on side of mixer. Push the shield back onto the mixer. The mixing shield will snap into place in

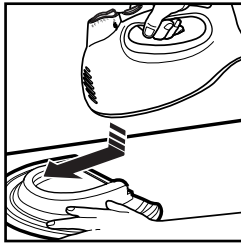

the groove around the mixer.

- Now insert the beaters or other attachments and use the mixer as you normally would.
- To remove:** Turn mixer off and unplug. Eject beaters or other attachments.
- Grasp mixing shield in one hand, while holding mixer in other hand. Pull shield straight out, then up, to remove.

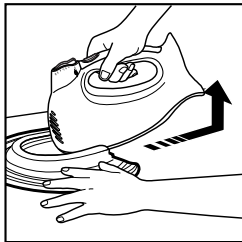

- Wash mixing shield in hot, soapy water. Rinse and dry.

Mixer Lockdown Button

Use this feature to lock the mixer in the “down” position when using on the stand.

Power Boost

Press and hold down the button for additional power at any speed.

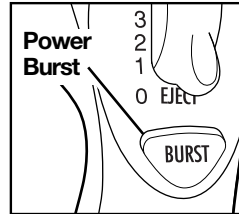

NOTE: Never use Power Burst for more than two minutes at a time or motor may overheat.

Bowl Rest™

This feature can be used on most large mixing bowls. Use the Bowl Rest while adding ingredients or checking a recipe. To use, TURN MIXER OFF, then set the mixer on the edge of the bowl.

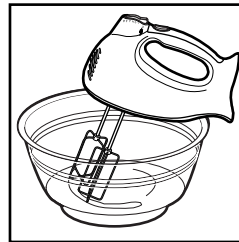

CAUTION:

- Never use Bowl Rest when mixer is on.
- Do not use Bowl Rest on small (1½ quart) mixing bowls or plastic mixing bowls.

Shift and Stir™ Bowl Lever

Use the lever to move the turntable. This allows you to position the beaters near the edge of the bowl or in the center.

Using Your Mixer

- Always make sure mixer is unplugged and speed control is set on OFF. Insert beaters. Use as hand mixer or assemble on stand.
- Plug mixer into electrical outlet.
- Move the speed control to desired speed, starting at 1 and increasing to a higher speed as necessary.
- If using as a stand mixer do not leave mixer unattended. Always monitor the progress of the mixing.

Using Your Mixer (continued)

5. When finished mixing, move the speed control to OFF and unplug mixer.

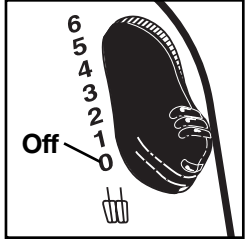

6. To eject beaters, push straight down on the speed control.

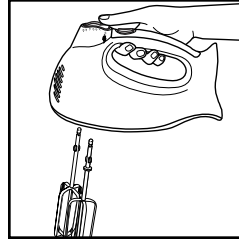

7. To remove mixer from stand, hold mixer and press mixer release button. Pull mixer to release from stand.

Mixing Guide

The following mixing guide is a suggestion for selecting mixing speeds. Begin on speed 1 and increase to desired speed depending on the recipe consistency.

6 SPEED	FUNCTION
0	OFF and/or Eject
1	LOW speed for folding or mixing in dry ingredients, muffins, or quick breads
2	To cream butter and sugar; most cookie dough
3	MEDIUM speed for most packaged cake mixes
4	Frosting and mashed potatoes; kneading dough
5	Beating egg whites; kneading dough
6	HIGH speed for whipping cream; kneading dough

Cleaning Your Mixer

1. Always unplug mixer from electrical outlet and eject the attachments before cleaning.
2. Wash attachments in hot, soapy water; rinse and dry.
3. Wipe the mixer body and cord with a clean, damp cloth.

NOTE: Do not use abrasive cleaners or scouring pads. To reduce the risk of electrical shock do not immerse the mixer body in water at any time.

Cord Wrap and Clip

When finished using the mixer, clean as instructed. Then wrap cord around mixer body as illustrated and secure cord in clip.

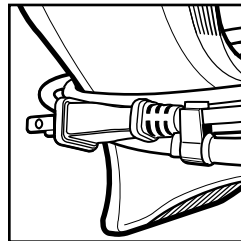

Recipes

Check our Web site for more recipes.

Lemon Chess Squares

18-ounce package yellow cake mix	1-pound box confectioners sugar
1 egg	2 eggs
½ cup butter or margarine, melted	¼ teaspoon lemon extract
8-ounce package cream cheese, room temperature	½ teaspoon vanilla extract

In a large mixing bowl combine dry cake mix, 1 egg, and butter. Mix until combined at Speed 1. Pat into ungreased 9x13-inch pan. With same mixing bowl and same beaters (not necessary to wash) beat cream cheese and sugar at Speed 2 until smooth. Add eggs and extract; beat at Speed 3 until well blended. Pour cream cheese mixture over top of cake in pan. Bake at 350°F for 45 to 50 minutes. Let cool then cut into bars. **Yield: About 36 bars.**

Fluffy White Frosting

Not as sweet as traditional butter cream frosting.

¾ cup vegetable shortening	5 to 6 tablespoons milk
1-pound box confectioners sugar	2 teaspoons vanilla extract
1 teaspoon salt	

Beat ingredients at Speed 4 for 3 minutes. **Makes enough to frost two 9-inch round layers.**

Ginger Cookie Bars

¾ cup vegetable shortening	2 teaspoons baking soda
1 cup sugar	1 teaspoon ground cinnamon
¼ cup molasses	½ teaspoon ground cloves
1 egg	½ teaspoon ground ginger
½ teaspoon vanilla	½ teaspoon salt
2 cups flour	

In a mixing bowl, using beaters combine shortening, sugar, molasses, egg, and vanilla at Speed 2 until smooth. Add flour, baking soda, cinnamon, cloves, ginger, and salt. Mix at Speed 2 until blended. Spread in an ungreased 15x10x1-inch baking pan. Bake at 375°F for 12 minutes or until lightly browned. Do not overbake. Cool on a wire rack before cutting. **Makes about 4 dozen bars.**

Brown Sugar Butterscotch Cookies

1 cup butter, room temperature	2½ cups flour
1 cup white sugar	½ teaspoon salt
1 cup brown sugar	1 teaspoon baking soda
2 eggs	4 cups crispy rice cereal
2 teaspoon vanilla	2 cups butterscotch chips

In a large mixing bowl, using beaters cream butter and sugars at Speed 2. Add eggs and vanilla and continue mixing. Add flour, salt, and baking soda and mix at Speed 3. Add rice cereal and chips and mix on Speed 3. Drop by spoonfuls onto cookie sheet. Bake at 350°F for 12 to 15 minutes or until lightly browned. **Makes 6 dozen.**

Double Dark Chocolate Cookies

12-ounce package semisweet chocolate chips	$\frac{2}{3}$ cup sugar
1½ cups flour	$\frac{2}{3}$ cup packed brown sugar
½ cup unsweetened baking cocoa	$\frac{3}{4}$ cup butter, room temperature
1 teaspoon baking soda	3 eggs
1 teaspoon salt	1 teaspoon vanilla

Melt chocolate chips and set aside to cool slightly. Stir together the flour, cocoa, baking soda, and salt into a bowl. In a large bowl, combine sugar, brown sugar, and butter. Beat with mixer at Speed 2 for two minutes. Add eggs, one at a time, beating after each addition. Add vanilla and beat another 30 seconds. Add melted chocolate and beat on Speed 1 until thoroughly mixed. Add the flour mixture and beat on Speed 1, gradually increasing speed to Speed 3 until thoroughly mixed. Drop by heaping tablespoons onto an ungreased baking sheet. Bake 10 to 12 minutes at 325°F. Allow cookies to cool on baking sheet for five minutes. Transfer to cooling racks to cool completely before storing.

Makes about 3½ dozen large cookies.

Zesty Mashed Potatoes

8 large baking potatoes, peeled, cubed, cooked, and drained	$\frac{1}{2}$ cup butter, room temperature
½ cup sour cream	$\frac{1}{2}$ cup milk
8-ounce package cream cheese, room temperature	$\frac{1}{2}$ to 1 teaspoon minced garlic
	Salt and pepper to taste

Place potatoes into a large bowl. Start mixing the potatoes at Speed 3 until they are smooth. Add sour cream, cream cheese, butter, milk, garlic, salt, and pepper and continue beating at Speed 4 until thoroughly mixed. Pour into a greased 9x13-inch baking dish. Bake uncovered for 30 minutes at 400°F. **Makes 8 servings.**

Blackberry Cobbler

2 to 3 cups fresh or 1 (14-ounce bag) frozen blackberries, thawed	1 cup flour
½ cup low fat margarine (40% vegetable oil), melted	1 cup sugar
¼ cup sugar	1½ teaspoons baking powder
	½ teaspoon salt
	1 cup milk

Place blackberries and melted margarine into a 9x13-inch baking pan. Sprinkle ¼ cup sugar over the berries and stir to blend in. In a medium bowl, combine flour, 1 cup sugar, baking powder, salt, and milk. Beat with mixer at medium speed for two to three minutes. Pour over the berry mixture. Bake at 325°F for 45 minutes. **Makes 8 servings.**

Creamy Peanut Butter Pie

½ cup butter	9-inch graham crust
¾ cup packed brown sugar	2 ounces semi-sweet chocolate
1 cup peanut butter	2 tablespoons butter
12-ounce container frozen whipped topping, thawed	

In a medium saucepan, combine butter and brown sugar. Cook over medium heat until butter is melted and mixture is smooth, stirring frequently. Refrigerate for 10 minutes. In a large bowl, beat peanut butter and brown sugar mixture at Speed 1 until blended. Increase to Speed 5 and beat one minute. Reduce to Speed 1 and add whipped topping. Beat one additional minute. Pour into graham crust and refrigerate. For topping: In a small saucepan over low heat, melt chocolate and 2 tablespoons butter. Stir constantly until smooth. Cool slightly then spread over top of pie. Refrigerate for several hours or overnight before serving. Store in refrigerator.

Baked Spinach-Parmesan Dip

10-ounce package frozen whole spinach, thawed	1 clove garlic, minced
1 cup mayonnaise	1 cup parmesan cheese
3-ounce package cream cheese, room temperature	⅛ teaspoon pepper
1 small onion, minced	½ teaspoon paprika
	2 baguettes, thinly sliced

Squeeze spinach to remove liquid and chop finely. In a medium bowl combine spinach, mayonnaise, cream cheese, onion, garlic, parmesan, and pepper. Beat ingredients at Speed 3 until well blended, about one minute. Spoon the mixture into a three or four cup baking dish that has been sprayed with vegetable spray. Sprinkle evenly with paprika. Bake in a 350°F oven until hot in center and lightly browned on top, 25 to 30 minutes. Serve hot to spread on baguette slices.

Chocolate Angel Food Cake

1½ cups confectioners sugar	½ teaspoon vanilla
1 cup flour	1½ teaspoons cream of tartar
¼ cup baking cocoa	½ teaspoon salt
1½ cups egg whites (about 10 eggs)	1 cup sugar

Combine confectioners sugar, flour and cocoa in a bowl and stir to mix. Set aside. Using hand mixer, in a large mixing bowl, beat egg whites, vanilla, cream of tartar, and salt at Speed 3 until soft peaks form. Increase to Speed 5 and add sugar, one tablespoon at a time, beating until stiff peaks form. Fold in the cocoa mixture by hand, about a fourth at a time. Spoon into an ungreased 10-inch tube pan. Carefully run a metal spatula or knife through batter to remove any air pockets. Bake on lowest oven rack at 375°F for 35 to 40 minutes or until the top springs back when lightly touched. Turn pan upside down and cool completely. Run a knife around edges and center of tube to loosen then remove cake.

Customer Service

If you have a question about your mixer, call our toll-free customer service number. Before calling, please note the model, type, and series numbers and fill in that information below. These numbers can be found on the bottom of your mixer. This information will help us answer your question much more quickly.

MODEL: _____ **TYPE :** _____ **SERIES:** _____

LIMITED WARRANTY

This product is warranted to be free from defects in material and workmanship for a period of two (2) years for Hamilton Beach Portfolio products or one (1) year for Hamilton Beach products from the date of original purchase, except as noted below. During this period, we will repair or replace this product, at our option, at no cost. THE FOREGOING WARRANTY IS IN LIEU OF ANY OTHER WARRANTY, WHETHER EXPRESS OR IMPLIED, WRITTEN OR ORAL INCLUDING ANY WARRANTY OF MERCHANTABILITY OR FITNESS FOR A PARTICULAR PURPOSE. ANY LIABILITY IS EXPRESSLY LIMITED TO AN AMOUNT EQUAL TO THE PURCHASE PRICE PAID, AND ALL CLAIMS FOR SPECIAL, INCIDENTAL AND CONSEQUENTIAL DAMAGES ARE HEREBY EXCLUDED. There is no warranty with respect to the following, which may be supplied with this product: glass parts, glass containers, cutter/strainer, blades, and/or agitators. This warranty extends only to the original consumer purchaser and does not cover a defect resulting from abuse, misuse, neglect, use for commercial purposes, or any use not in conformity with the printed directions. This warranty gives you specific legal rights, and you may also have other legal rights which vary from state to state, or province to province. Some states or provinces do not allow limitations on implied warranties or special, incidental or consequential damages, so the foregoing limitations may not apply to you.

If you have a claim under this warranty, DO NOT RETURN THE APPLIANCE TO THE STORE! Please call our CUSTOMER SERVICE NUMBER. (For faster service please have model, series, and type numbers ready for operator to assist you.)

CUSTOMER SERVICE NUMBERS

In the U.S. 1-800-851-8900

In Canada 1-800-267-2826

Web site address: www.hamiltonbeach.com

KEEP THESE NUMBERS FOR FUTURE REFERENCE!

HAMILTON BEACH  PROCTOR-SILEX, INC.

263 Yadkin Road
Southern Pines, North Carolina 28387

PROCTOR-SILEX CANADA, INC.

Picton, Ontario K0K 2T0