



11 Pint Smart-Touch Dehumidifier User Guide

IVA20PDEHU

Thank you for purchasing the Ivation® 11 Pint Smart-Touch Dehumidifier. This User Guide is intended to provide you with guidelines to ensure that operation of this product is safe and does not pose risk to the user. Any use that does not conform to the guidelines described in this User Guide may void the limited warranty.

Please read all directions before using the product and retain this guide for reference. This product is intended for household use only. This product is covered by a limited one-year warranty. Coverage is subject to limits and exclusions. See warranty for details.



Box Contents

Dehumidifier

User guide

Safety Precautions

- Install the unit on flat and hard floor to diminish vibration or noise.
- Never immerse the unit in water or other liquids.
- Never operate the unit if the cable or other connector is damaged, or something abnormal may happen, please call customer service for help.
- Disconnect the unit from power supply when it is not in use, or before relocating or cleaning it.
- Operate the unit only at the voltage specified.
- The unit is for indoor use only. Don't use it for other purpose.
- Do not put heavy objects on the appliance.
- Do not tip the unit to any side as spilt water could damage the appliance.
- Never insert any object into the unit body to avoid any hazard or unit failure.
- Do not put the unit close to heat-generating devices or near flammable and dangerous materials.
- This appliance is not intended for use by persons (including children) with reduced physical, sensory or lack of experience and knowledge, unless they have been given supervision or instruction concerning use of the appliance by a person responsible for their safety. Children should be supervised to ensure that they do not play with the appliance.
- If the supply cord is damaged, it must be replaced by the manufacturer or its service agent or a similarly qualified person in order to avoid a hazard.
- The appliance must be positioned so that the plug is accessible.
- The appliance should be installed in accordance with national wiring regulations.
- The ambient temperature range for the appliance is 41°F–95°F (5°C–35°C).
- Don't try to repair, dismantle or remold the appliance, or it may become damaged. Even changing the power cord should be done by special qualified person.

Parts

- A. Touch panel
- B. Top air outlet
- C. Side air inlet
- D. Side panel
- E. Purify component
- F. Turbofan
- G. Motor
- H. Condenser
- I. Evaporator
- J. Temperature and humidity sensor
- K. Compressor
- L. Float
- M. Reservoir
- N. Filter
- O. Back air inlet

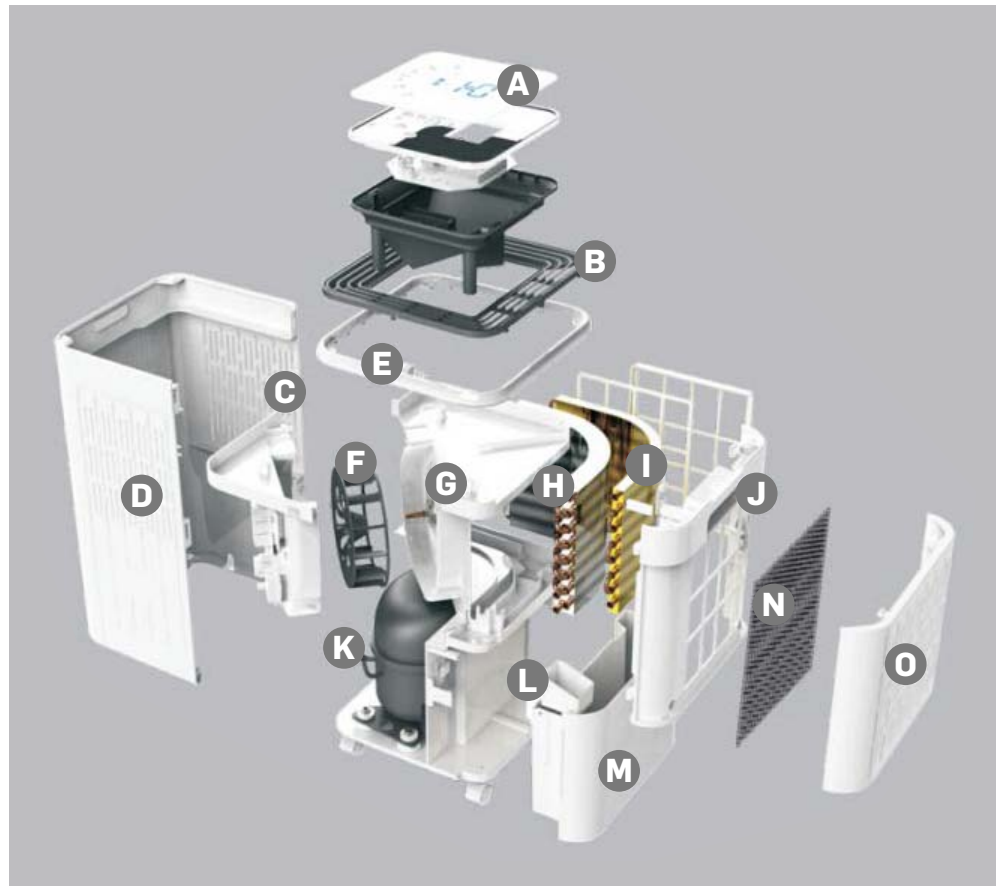

Control Panel

- A. Ion
- B. Timer
- C. Reservoir full indicator
- D. Power
- E. Continuous mode indicator
- F. Humidity setting
- G. Fan speed

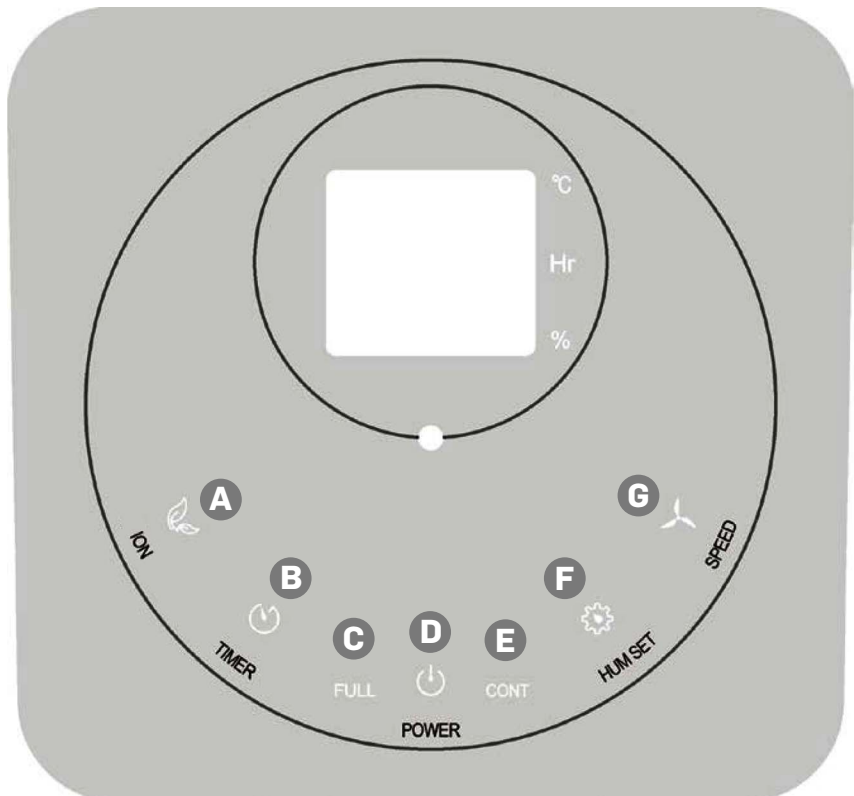

Operation



Power:

1. Press the POWER key to turn the unit on.
 - a. The dehumidifier will automatically enter continuous mode, and the CONT icon will glow red on the control panel.
 - b. The fan speed will automatically be set to high, and the SPEED icon will glow red on the control panel.
2. Press the power key again to turn the unit off. The fan will continue running for 10 seconds before powering off.

NOTE 1: When plugged in, the control panel will glow blue.

NOTE 2: When operating, the control panel icons will glow red.



Humidity settings:

1. Press the HUM SET key to exit continuous mode and enter smart mode.
2. Each press of the key will increase the humidity level by 5% from 40%–80%. When the indoor humidity is lower than the set humidity, the machine would stop automatically.
3. 5 seconds after the humidity is set, the room's current humidity will be displayed on the control panel.
4. Press and hold the key for 3 seconds to view the current temperature.

NOTE 1: The default humidity level is 60%.

NOTE 2: If the humidity displays as "--%", the system is currently in continuous mode.



Timer:

1. Press the TIMER button to set the 24 hour timer.
2. Each press will add 1 hour to the timer, up to 24 hours.
3. To turn off the timer, press the TIMER button until the displayed time is "--"

NOTE: When the timer is set, the TIMER icon will glow blue.



Fan Speed:

1. Press the SPEED button to switch the fan between high and low speed.

NOTE 1: When high speed is selected, the SPEED icon will glow red.

NOTE 2: When low speed is selected, the SPEED icon will glow blue.



Ion:

1. Press this button to activate the ion feature.
2. This feature can be used independently of the dehumidifying feature.

NOTE: When the ionizer is on, the ION icon will glow blue.

Status codes



LO: the current humidity is below 20%



HI: the current humidity is above 95%

Removing Collected Water

When the reservoir is full, the unit will beep 15 times and the FULL indicator will glow red.

NOTE: The unit will stop operating while the FULL indicator light is on.

Collected water can be removed in the following ways:

1. When the water reservoir is full, remove and empty it, as illustrated in FIG 1.
2. Continuous draining: water can be automatically emptied into a floor drain by attaching the unit to a water hose with a female threaded end (not included).
 - a. Remove the water reservoir from the unit as illustrated in FIG 1.
 - b. Connect your hose to the water outlet as illustrated in FIG 2.
 - c. Lead the other end of the hose to a floor drain or other location where you want the water to flow, as indicated in FIG 3.
 - d. Place the reservoir back into the unit, leading the hose out through the slot.



FIG 1

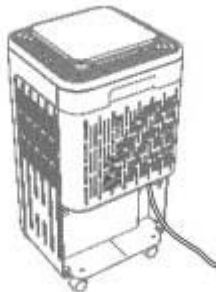

FIG 2

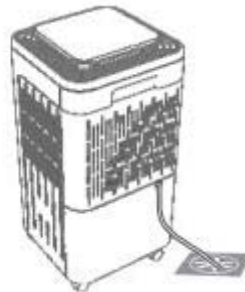

FIG 3

Drainage notes:

1. Do not block the water outlet or hose.
2. Do not bend the drainage hose or risk damage to the unit.
3. The reservoir must be in place in order for the unit to operate.
4. The unit will stop running if the reservoir is removed.
5. Do not remove the float from the reservoir, or the control panel will display FULL and stop working.
6. When the reservoir is full, drain the reservoir and reset the unit.
7. When placing the reservoir back in the unit, use two hands to push it securely into its place.

Care and Maintenance

Always turn off and unplug the dehumidifier before performing any kind of maintenance.

Cleaning:

- Clean the housing with a soft moist cloth. Do not use chemical solvents (such as benzene, alcohol, gasoline). The surface may be damaged or even the whole case may be deformed.
- Do not clean with water.

Air filter:

- To wash the air filter, immerse it in warm water with a neutral detergent. Rinse and dry it thoroughly in a shaded place.
- Clean the washable filter every 2 weeks. If the filter is blocked with dust, the efficiency will reduce.

Storage:

- Drain the reservoir completely and make sure no more water is inside.
- Unplug the unit and fold up the power supply cord.
- Remove and clean the air filter, allow it to dry completely and reinstall it.
- Store the dehumidifier in a cool, dry location, away from direct sunlight, extreme temperature, and excessive dust.

Troubleshooting

Problem	Possible Cause	Solution
The unit doesn't operate	No power supply	Connect to a functioning outlet and switch on
	The reservoir is full	Drain the reservoir and make sure it is securely in place. Then reset the unit
	The room temperature is under 41° and the error shows "CL" Or the room temperature is above 95° and the error shows "CH"	Built in safety features prevent this unit from operating at these temperatures
	Timer function is active	Deactivate timer function
The dehumidifying function doesn't work or the unit turns on / off frequently	The air filter may be clogged	Clean the air filter
	The door/window may be open	Close the door/window
	The unit may be close to a heat source	Move the unit to a cool place
	The vents may be blocked	Remove the obstruction from the vents
E1 error code	Evaporator sensor problem	Remove the connection mouth and plug it in again. If this does not solve the problem, change the sensor.
E2 error code	Humidity sensor problem	Remove the connection mouth and plug it in again. If this does not solve the problem, change the sensor.

Specifications

Power Supply: 115V/60Hz
 Power Consumption: 230W/ 2.5A @ 80°F, 60% RH; 270W/2.9A @ 86°F, 80% RH
 Dehumidify Capacity: 11Pints/Day @ 80°F, 60% RH
 Reservoir Capacity: 3.5 pints (2L)
 Noise: ≤45dB(A)
 Air Circulation: 71CFM
 Refrigerant / Charge: R134a/3.88 oz. (110g)
 Working Temp.: 41°F–95°F
 Recommended Room Size: 160–215 sq. ft.
 Timer: 0–24hr
 Auto Defrost: Yes
 Button: Touch
 Dimensions: 10" ×9.6" ×19.5"
 Net Weight: 22 lbs.

Customer Service:

info@myivation.com
 866-849-3049

Distributed by
 C&A Marketing, Inc.
 114 Tived Lane East
 Edison, NJ 08837 USA

Europe: C&A Europe
 167 Hermitage Road
 Crusader Industrial Estate
 London N4 1LZ
 United Kingdom

info@myivation.com

Made in China
 Ivation and the Ivation logo are registered
 trademarks of C&A Holdings, LLC in the U.S.
 ©2017 All rights reserved