

NOTES:

1. HOLD ROUGH-IN DIMENSIONS $\pm 1/4"$ (6.4mm).
2. WHEN INSTALLING THIS UNIT, LOCAL, STATE, OR FEDERAL CODES SHOULD BE ADHERED TO. FOR INSTALLATION HEIGHTS OTHER THAN SHOWN, DIMENSIONS MARKED (*) MUST BE ADJUSTED ACCORDINGLY.
- 3 REFER TO 5874/VRK5874 OPERATION AND MAINTENANCE MANUAL FOR PUSH BUTTON AND VALVE INSTALLATION/MAINTENANCE INSTRUCTONS.



1455 KLEPPE LANE
SPARKS, NEVADA 89431
(775) 359-4712 FAX (775) 359-7424
E-MAIL: HAWS@HAWSCO.COM
WEBSITE: WWW.HAWSCO.COM

ECN NO.	REVISED PER	BY:	MODEL(S)	PART NUMBER
	ECN: 4797	HM	1431	0002076851.D
DRAWN:	DATE:	CHK'D:		DRAWING NO.
PM	09/20/00			14819A00
APPROVED:	DATE:		SCALE: 1:10	DRAWING NO. 13
			DRAWING TYPE: INSTALLATION	SHEET 1 OF 2

4. CONNECT WHITE "POLYPROPYLENE" TUBING ON PRESSURE SIDE (INLET) OF VALVE.
5. CONNECT CLEAR "POLYETHYLENE" TUBING ON FREE FLOW SIDE (VALVE TO BUBBLER HEAD) ONLY.

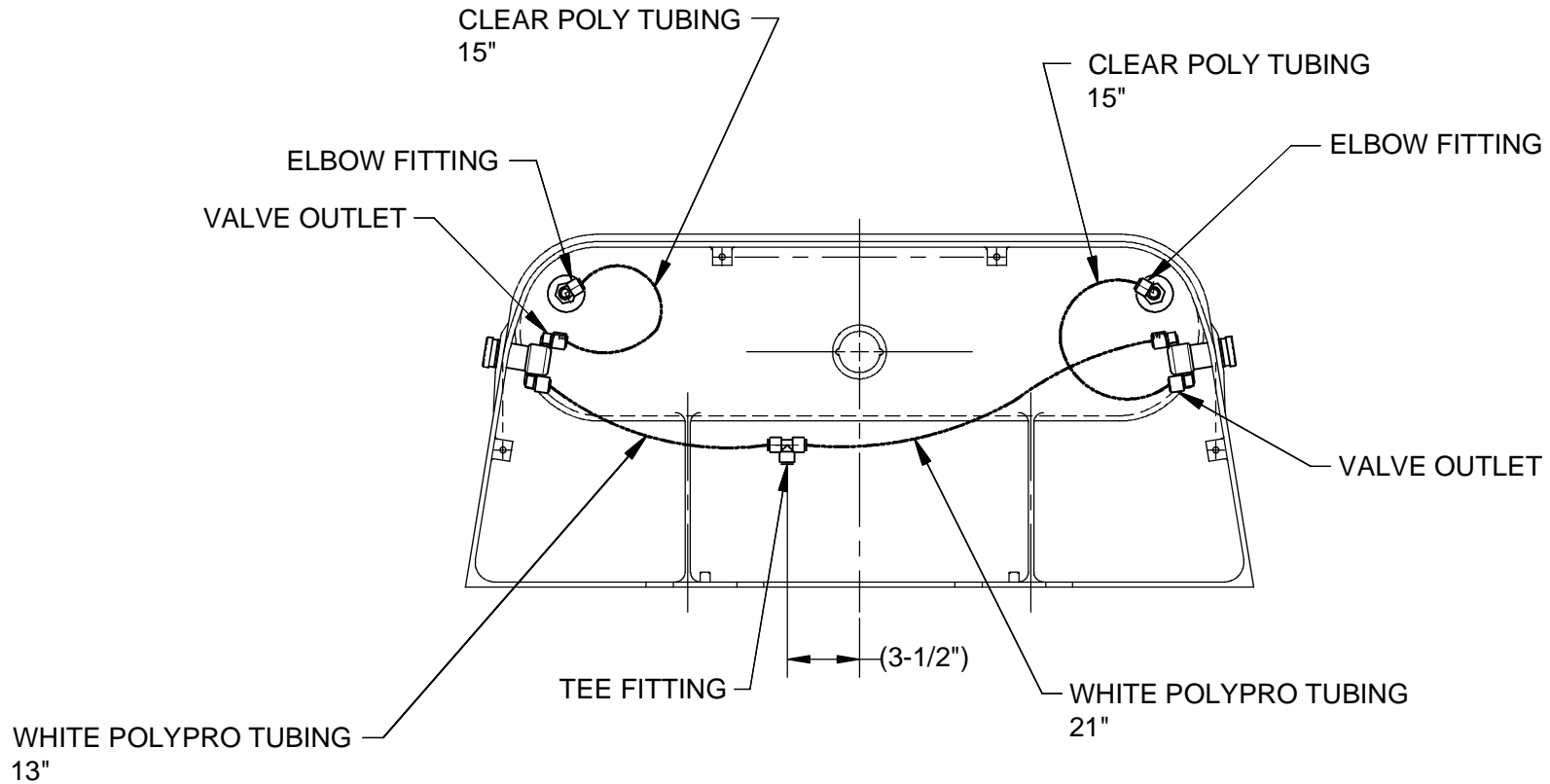

		1455 KLEPPE LANE SPARKS, NEVADA 89431 (775) 359-4712 FAX (755) 359-7424 E-MAIL: HAWS@HAWSO.COM WEBSITE: WWW.HAWSO.COM	
		ECN NO. REVISED PER BY: MODEL(S) ECN: 4797 HM	PART NUMBER 0002076851.D
DRAWN: PM DATE: 09/20/00	DATE: CHK'D.: DATE:	1431	DRAWING NO. REV 14819A00 13
APPROVED:	DATE:	SCALE: 1:10	DRAWING TYPE: INSTALLATION SIZE: A SHEET 2 OF 2