

Gateway Label

The gateway label is located on the bottom of your SBG7580-AC.

To receive high-speed Internet service, your service provider may request the Media Access Control (MAC) address (see **HFC MAC ID**) and Serial number (see **S/N**) listed on the gateway label.

If the label is not attached, please refer to the bottom of your gateway.

You may need the following gateway label information to activate your gateway and set up a wireless network connection:

- **Model** – Gateway model name
- **SSID** – Default network name of your wireless network. It is highly recommended that you change the default network name or add additional wireless networks.
- **WI-FI SECURITY KEY** – Wireless network password to access your wireless network. It is highly recommended that you change the default Wi-Fi Security Key to a more secure password to protect your wireless network from unauthorized access.
- **S/N** – Gateway serial number. Your service provider may request this number to activate your gateway.
- **HFC MAC ID** – Your service provider may request the Media Access Control (MAC) number to activate your gateway.

© 2016 ARRIS Enterprises, LLC. All rights reserved.

No part of this publication may be reproduced or transmitted in any form or by any means without written permission from ARRIS Enterprises, LLC.

ARRIS, SURFboard, and the ARRIS logo are all trademarks or registered trademarks of ARRIS Enterprises, LLC. Other trademarks and trade names may be used in this document to refer to either the entities claiming the marks or the names of their products. ARRIS disclaims proprietary interest in the marks and names of others.

ARSVD01709-b 10/2016



SURFboard™ SBG7580-AC Wireless Gateway

Quick Start Guide

In the Box

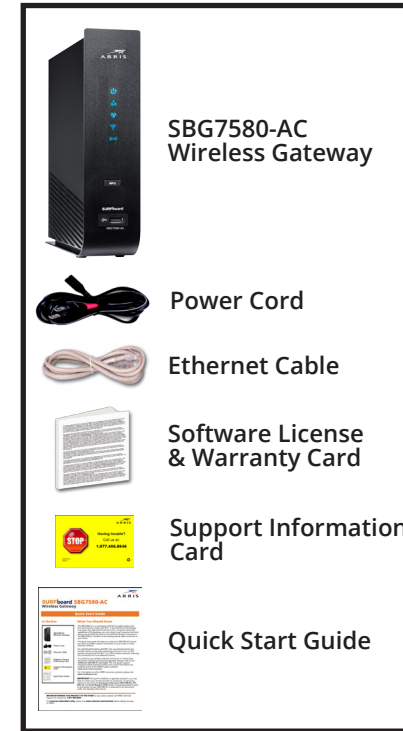

What You Should Know

The SBG7580-AC is a combination DOCSIS 3.0 cable modem and four-port Ethernet router with Wi-Fi. It uses DOCSIS 3.0 technology to provide ultra high-speed Internet access. Using the connection capabilities of the gateway, you can connect your computer and other devices via the Ethernet ports or two different Wireless connections. The SBG7580-AC connects to the existing coaxial cable connection in your home.

This quick start guide will help you install your SBG7580-AC and set up a secure wireless network connection on your home or small business network.

For optimal performance with 802.11ac, you should connect any wireless devices using older networking protocols to the 2.4 GHz wireless network (not the 802.11ac 5 GHz wireless network), reserving this connection for more advanced clients.

To customize your wireless network connection or review other connection methods and advanced gateway settings, refer to the *SURFboard SBG7580-AC User Guide*. The user guide, support frequently asked questions (FAQs), and contact information are available online at the ARRIS Support website: www.arris.com/consumers.

For information on other ARRIS consumer products, please visit www.surfboard.com.

IMPORTANT! During the installation or gateway activation, you may have to contact your service provider for assistance. To save time, make sure you have the **Gateway model name (SBG7580-AC)**, **HFC MAC ID**, and **Serial Number (S/N)** listed on the gateway label located on the bottom of your SBG7580-AC or attached to this document under the Gateway Label section.

BEFORE RETURNING THIS PRODUCT TO THE STORE for any reason, please call ARRIS Technical Support for assistance: **1-877-466-8646**

For **Comcast subscribers only**, please visit www.comcast.com/activate before calling Comcast or ARRIS.

Install the Gateway

1. Connect the coaxial cable from the cable wall outlet or RF splitter (not included) to the **Cable** connector on the rear of your SBG7580-AC.
Use your hand to tighten each connector.
2. Connect the Ethernet cable to the **Ethernet** port on your Ethernet-enabled device and to any available **Ethernet** port on the rear of your SBG7580-AC.
3. Connect the power cord to the **Power** port on the rear of your SBG7580-AC and then plug it into an electrical wall outlet that is not controlled by a wall switch.

This automatically powers ON your SBG7580-AC.

4. Check the front panel LEDs on your SBG7580-AC.

During the initial startup, the **Power**, **Send/Receive**, and **Online** LEDs will FLASH. Afterwards, check that all three LEDs are lit SOLID green or blue. Both **Wireless** LEDs will light up only when wireless devices are connected. See **Front Panel LEDs** for more information.

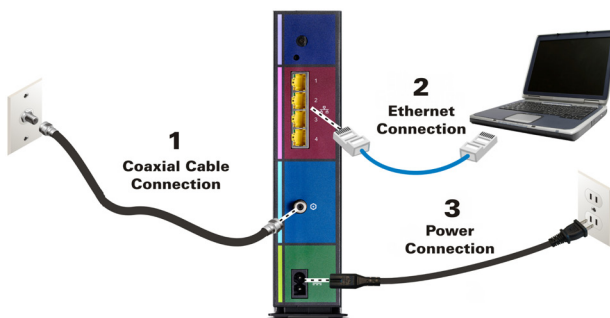

Test the Gateway Connection

1. Power ON your computer and log in.
2. Contact your service provider to activate (provision) your SBG7580-AC.
3. Open a web browser on your computer, such as Internet Explorer, Google Chrome, Firefox, or Safari.
4. Type a valid URL (such as www.surfboard.com) in the address bar and press **Enter**.

The ARRIS website should open. If it fails to open, please contact your service provider to set up your Internet service or activate your gateway.





Front Panel LEDs

During normal operation, the **Power**, **Send/Receive**, and **Online** LEDs on the SBG7580-AC front panel should always be lit SOLID green or blue.

Note: During startup, the first three LEDs will FLASH and then light up SOLID in sequence. If the **Power** LED does not light up, please first check the gateway power connection before contacting ARRIS. If the other LEDs do not light up correctly, please call ARRIS Technical Support at **1-877-466-8646**.



LED Status

	ON - Power is properly connected to the gateway
	ON - Upstream (Send) and Downstream (Receive) status
	ON - Gateway is connected to the network
	FLASH - 2.4 GHz wireless connection is made between the gateway and wireless device
	FLASH - 5 GHz wireless connection is made between the gateway and wireless device

Set Up a Wireless Network Connection

Choose one of the following options to set up your wireless network connection. When done, proceed with **Test Your Wireless Network Connection**.

- Computer Wireless Network Options (**A**)
- WPS Pairing Button (**B**)

A Set Up the Wireless Network on Your Computer

Note: The steps for setting up a wireless network may differ slightly depending on the operating system installed on your computer. The following steps apply to Windows® 7.

1. From the Windows task bar on your computer, click the following in sequential order to open the list of available wireless networks:
 - **Start** button
 - **Control Panel**
 - **Network and Sharing Center**
 - **Connect to a network**
2. Scroll down the list and then click on the wireless network name or SSID for your SBG7580-AC.
The SSID, **SBG7580AC-XXXX**, is listed on the gateway label.
3. Select **Connect automatically** to set up automatic log on connections for the wireless devices on your home network.
4. Click **Connect** to open the Connect to a Network window.
5. Type your wireless network security code or password in the **Security key** field.

Note: Enter the **Wi-Fi Security Key** listed on the gateway label or create your own network password (see the **SURFboard SBG7580-AC User Guide** for more information).

- The **Successfully added** message should display.
6. Close the Wireless Network Connection window.

B Use the WPS Pairing Button

To use WPS, your computer hardware must support WPS and also have WPA security compatibility.

WPS automatically assigns a random SSID wireless network name and Wi-Fi Security Key to connect your SBG7580-AC and other WPS-enabled wireless devices to your wireless network.

Do the following to connect your WPS devices:

1. Power ON your SBG7580-AC and other WPS-enabled wireless devices that you want to connect to your wireless network.
2. Press the **WPS** button located on the top of your SBG7580-AC.
3. Press and hold the **WPS** button on your WPS-enabled wireless computer or other WPS device for five or more seconds, then release.
4. Repeat steps 2 and 3 for each additional WPS-enabled wireless device.

Test Your Wireless Network Connection

1. If connected, disconnect the Ethernet cable from your computer and SBG7580-AC.
2. Open a web browser on your computer.
3. Type a valid URL (such as www.surfboard.com) in the web browser address bar and press **Enter**.

Start the Gateway Web Manager

Use the SBG7580-AC Web Manager to set up and manage your wireless gateway and network security configurations. To access the web manager:

1. Open any web browser on your computer, type **192.168.0.1** in the address bar, and press **Enter**.
2. Type the default user name: **admin**.
3. Type the default password: **password**.
4. Click **Apply** to open the web manager.