

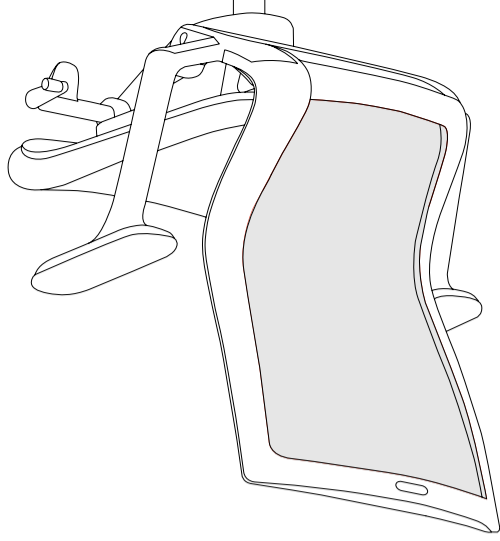

Scan QR Code for Assembly Video



Assembly Instructions

T50 Series

FURSYS GROUP

Caution

- Please read the assembly instruction sheet completely before assembly.
- Remove all parts from carton and ensure all parts are included prior to assembly.
- Assemble the chair on the carton or table to prevent scratching the chair.
- Do not use power tools.
- Examine all packaging materials and remove staples before discarding carton.
- For immediate help with assembly or product information, please contact customer@sidiz.com.
- The parts of the product may be slightly different from the pictures.

[Using the allen wrench]

1. Use the allen wrench when you assemble the bolts.
2. Use the long end of the allen wrench when the bolts need to be fastened quickly.
3. Use the short end of the allen wrench for final tightening.

SIDIZ is not responsible for any claims/defects on products or wounds on the user caused during assembly.

Parts List

Backrest



Seat Pan

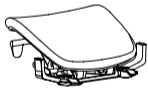

Armrest

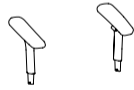

Gas Lift



Screws for Armrest Assembly



Star Base

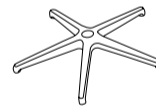

Casters



Wrench



Screws for Backrest Assembly



• Spare

Spare Screws for Backrest Assembly



• Option

Headrest



Screws



Headrest Cover



01 Armrest and Seat Pan Assembly

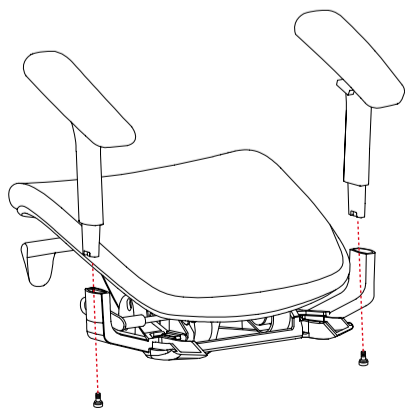

1. Prepare 2 bolts and a wrench for each armrest.

2. Insert an armrest into the seat pan and assemble with bolts.

02 Backrest and Seat Pan Assembly

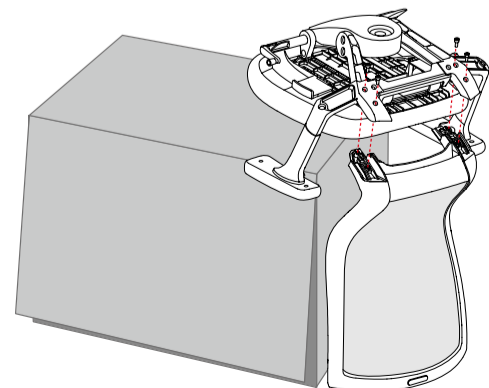

1. Prepare 4 bolts and a wrench for backrest assembly.

2. Match the backrest into the seat pan and assemble with bolts.

03 Star Base, Gas Lift Assembly

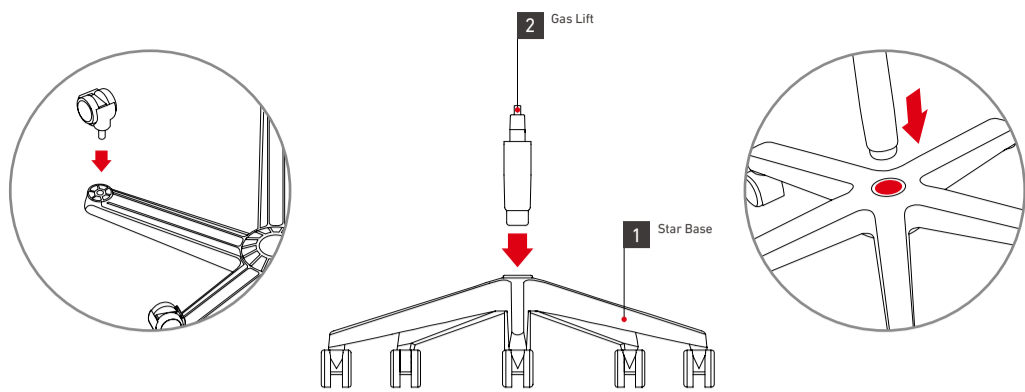

1. Assemble on a smooth surface in order not to scratch the parts.

2. Turn the star base **1** upright and insert the gas lift **2** into the center hole of Star Base.

04 Final Assembly

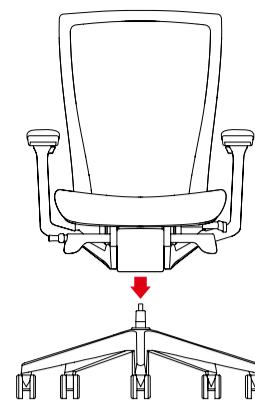

1. Combine the upper part of the chair with the already assembled bottom part.
2. Fix the cylinder on to the hole located below the upper part of the chair.

3. After installing the cylinder, sit on the chair and check if the chair height adjustment lever is fully functional.

01 Headrest (Option) - Cover Assembly

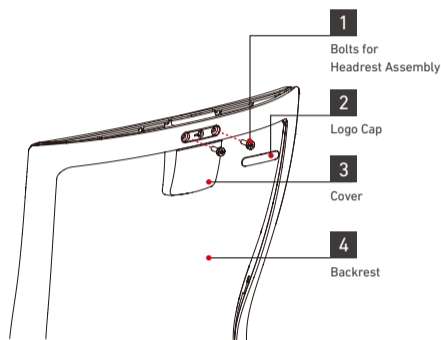

1. Place the headrest cover **3** and use 2 bolts **1** to install it with the backrest **4**. Then attach the logo cap **2** into the backrest.

02 Headrest (Option) - Headrest Assembly

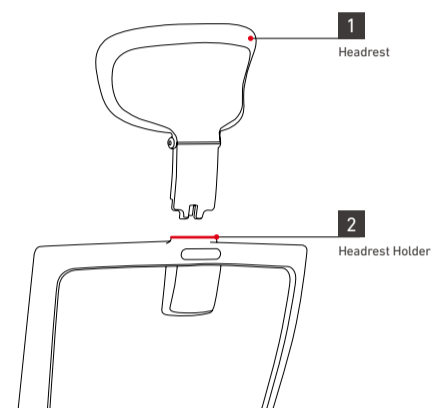

1. Insert the headrest **1** to the headrest holder **2** on the top of the Backrest.

Seat cover for T50 air - Putting on the seat cover

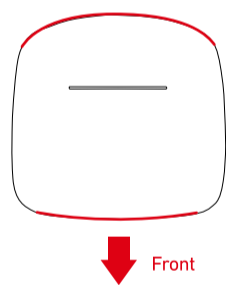

1. Place the cover so that the flat line comes to the front.

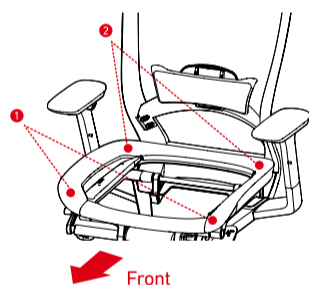

2. Cover the front part of the chair first, and move to the back in sequence.

Seat cover for T50 air - Taking the cover off

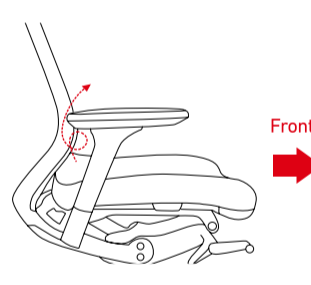

1. When taking the cover off, peel from the back side of the chair.