



ApexDesk™

ELECTRIC HEIGHT-ADJUSTED SIT TO STAND DESK

Vortex Series 2-leg Desk Assembly Guide

For desk with underframe Model No. AL4628-XX



REV-1509A

Table of Contents

IMPORTANT SAFETY INSTRUCTIONS.....	3
CAUTION, USE & LIABILITY.....	4
PARTS & HARDWARE.....	5
ASSEMBLY INSTRUCTIONS.....	6
CARE INSTRUCTIONS.....	11
TECHNICAL SPECIFICATIONS.....	11
WARRANTY INFORMATION.....	12
CONTACT INFORMATION.....	12

IMPORTANT SAFETY INSTRUCTIONS

WARNING -When using electric appliances, basic precautions should always be followed, including the following:

- A) Read all the instructions before using the appliance.
- B) To reduce the risk of injury, close supervision is necessary when an appliance is used near children.
- C) Do not contact moving parts.
- D) Only use attachments recommended or sold by the manufacturer.
- E) Do not use outdoors.
- F) To disconnect, turn all controls to the off ("O") position, then remove plug from outlet.
- G) Do not unplug by pulling on cord. To unplug, grasp the plug, not the cord. Unplug from outlet when not in use and before servicing or cleaning
- H) Do not operate any appliance with a damaged cord or plug, or after the appliance malfunctions or is dropped or damaged in any manner. Return appliance to the nearest authorized service facility for examination, repair, or electrical or mechanical adjustment.
- I) Connect to a properly grounded outlet only. See grounding Instructions below.

GROUNDING INSTRUCTIONS

This appliance must be grounded. In the event of malfunction or breakdown, grounding provides a path of least resistance for electric current to reduce the risk of electric shock. This appliance is equipped with a cord having an equipment-grounding conductor and a grounding plug. The plug must be plugged into an appropriate outlet that is properly installed and grounded in accordance with all local codes and ordinances. This appliance is for use on a nominal 120 V circuit, and has a grounding plug that looks like the plug illustrated in sketch A.

A temporary adaptor, which looks like the adaptor illustrated in sketches B and C, may be used to connect this plug to a 2-pole receptacle as shown in sketch B if a properly grounded outlet is not available. The temporary adaptor should be used only until a properly grounded outlet can be installed by a qualified electrician. The green colored rigid ear, lug, and the like, extending from the adaptor must be connected to a permanent ground such as a properly grounded outlet box cover. Whenever the adaptor is used, it must be held in place by the metal screw.

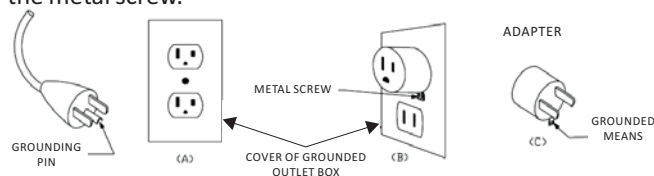

CAUTION, USE & LIABILITY

CAUTION

Make sure no obstacles are in the desk's path. Make sure the desk is not touching any walls. Make sure all cords are of appropriate lengths to accommodate the change in desk height.



Keep children away from electric sit to stand desks, control units and handsets.



Keep all electrical components away from liquids.



Do not sit or stand on desk. Do not crawl or lie under desk.



Do not place any objects taller than 20" underneath desk.



Do not open any of the components lifting columns, control box, or controller.
There is a risk of electric shock.

USE & LIABILITY

This sit to stand adjustable desk has electric motors and is designed for use in an indoor environment and dry work areas only. The desk height is adjustable so that it can be positioned at the most suitable height. Any other use is at user's risk. Under no circumstances does the manufacturer accept warranty claims or liability claims for damages caused from improper use or handling of the desk.

PARTS & HARDWARE

PARTS DIAGRAM

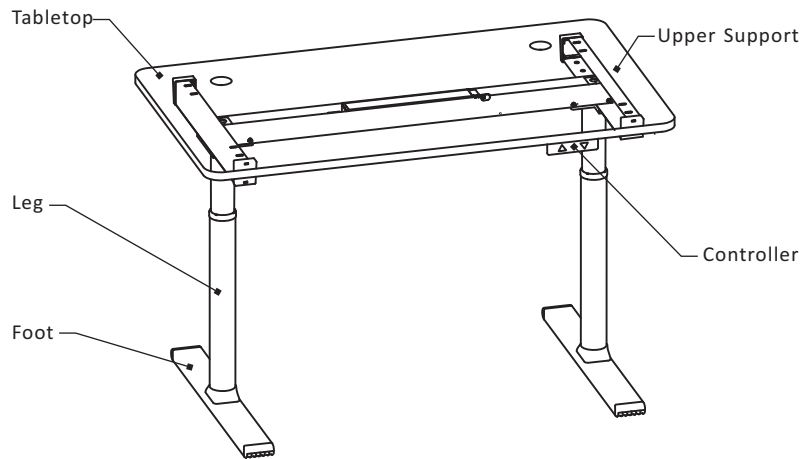

PARTS LIST

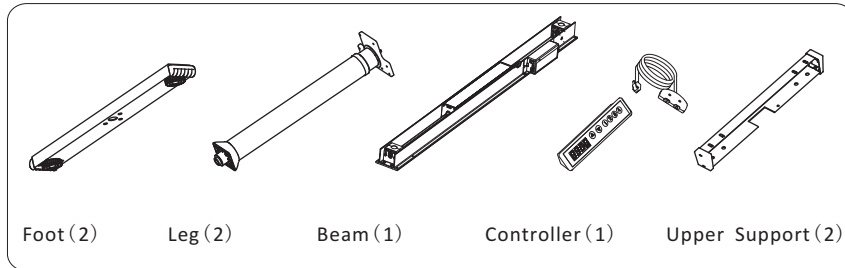

HARDWARE LIST

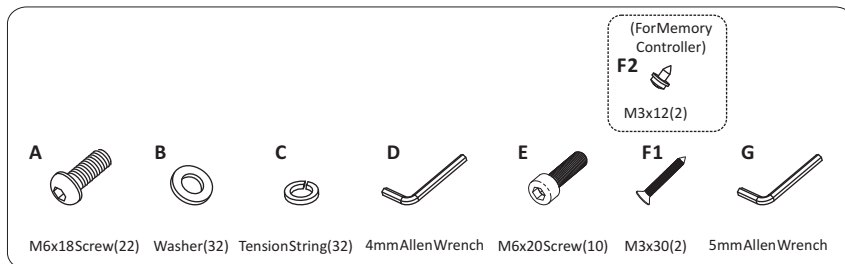

ASSEMBLY INSTRUCTIONS

BEFORE YOU BEGIN

1. Lay out all components and hardware to ensure that you have all the parts listed on the parts on page 5.
2. Desk weighs close to 100 lbs. Two people are needed to turn or move desk and some of its components. When turning or moving the assembled desk, grab it by UPPER SUPPORTS (not desk top).
3. Assemble on soft and non-abrasive surface to avoid scratch or damage to the desk top.

STEP 1

Lay the lower support (foot) flat on the floor and secure it to the leg with Screw E as illustrated below. Make sure to use longer socket-headed BLACK Screw E not shorter dome-headed Screw A.

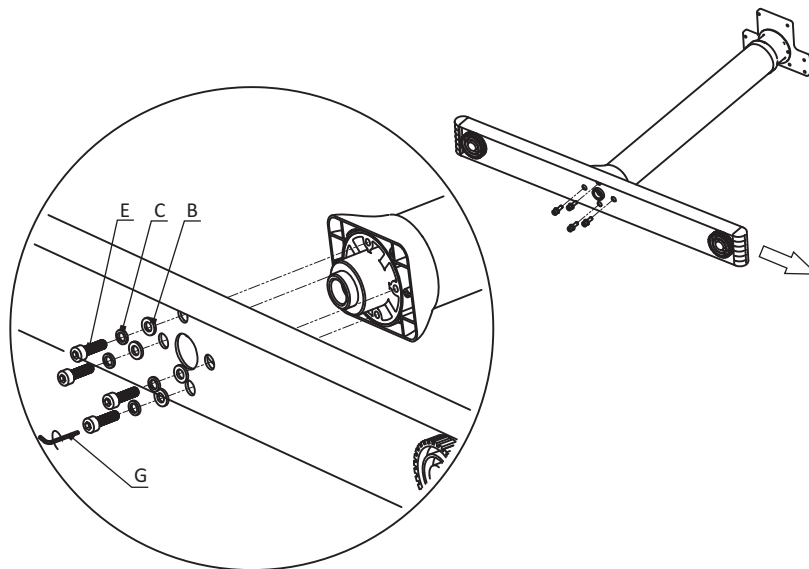

The foot is hollow. In an unlikely event that a screw or washer falls into the foot, you can get it out by unscrewing the leveling stud and prying open the plastic ender with a flat screwdriver. You may also choose not to do anything as extras are provided.

STEP 3

Use Screw A to secure two upper supports to the beam.

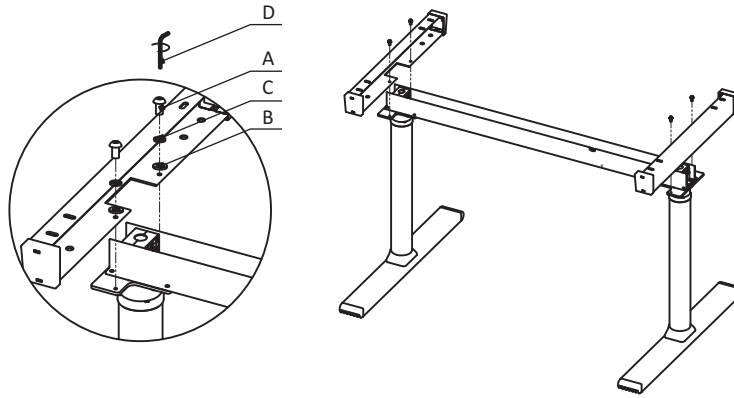

STEP 4

Lay the tabletop on a soft and non-abrasive surface. Carefully move the underframe onto the top, align the holes on the upper supports to the pre-drilled anchors on the top. Secure the top with Screw A. Don't over-tighten the screws.

Use Screw F1 to mount non-memory controller. Please note that pre-drilled holes are only available on the right side. Non-memory controller looks identical on both sides. The upper side of non-memory controller is labeled "Attach this side to tabletop".

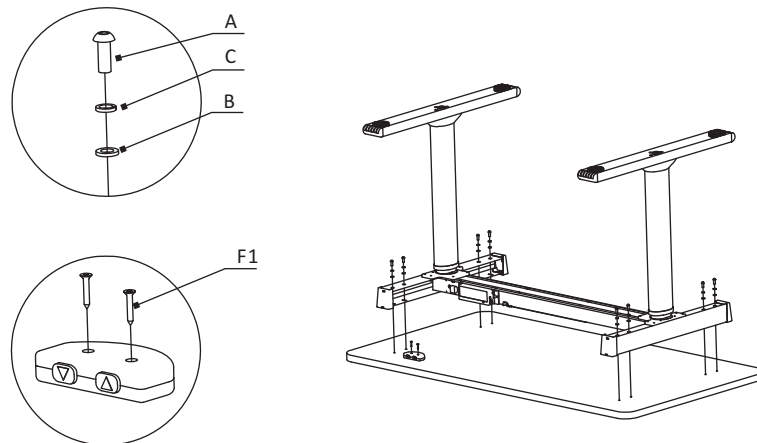

STEP 4-1 (Memory Controller Option)

Use Screw A to secure top and Screw F2 to secure controller.

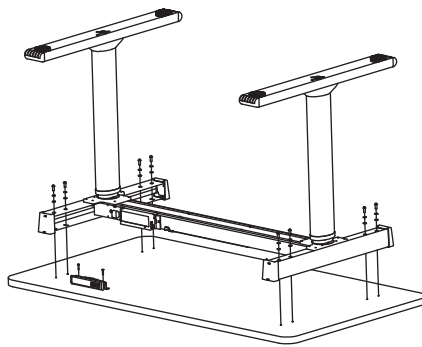
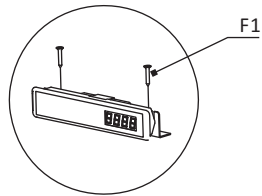
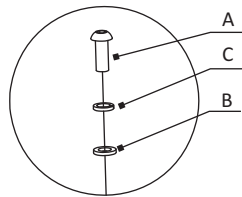

STEP 5

Connect controller to control box. Connect power to a wall plug. If the desk is unsteady, check all screws and make sure they are all tight, and make adjustment to the leveling studs. Please note that minor unsteadiness is common for all standing desks at standing height especially when it is on a hard surface like hardwood floor.

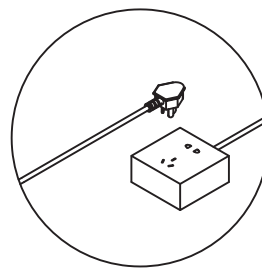
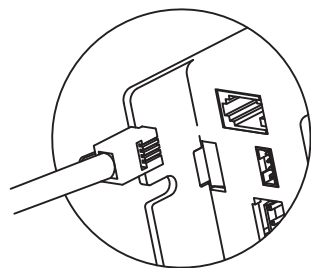

Memory Function Controller for Desk Underframe Model# AL4628-2M

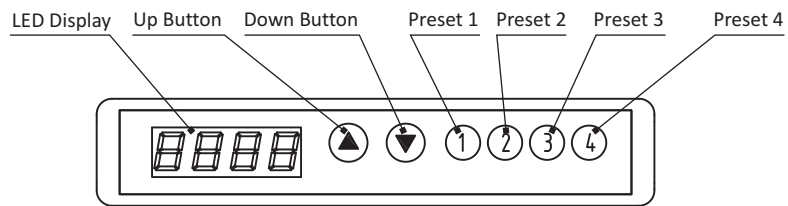

- a. LED panel displays minimum height of 28.5" and maximum height of 46.6"
- b. Factory default settings for four memory buttons are 32.1", 35.7", 39.3" and 42.9" respectively.
- c. To set your own height, press up or down button until the desk reaches the desired height, press and hold memory button until you hear two beeps. Factory setting will be erased once you set your own.
- d. LED light turns off by itself if inactive for 5 seconds and turns back on when any button is pressed.

TROUBLESHOOTING

Problem(s)	Solution
Desk is unsteady.	All standing desks have some degree of unsteadiness at standing height especially on a hard surface like hardwood floor. Adjust leveling stud, or put a rug under it if necessary. Check all screws and make sure they are all tight.
Desk does not go up or down.	Check all connections. Make sure controller box is plugged into a power outlet and controller is plugged into control box.
Desk goes up or down unevenly.	Make sure BOTH spindles are set properly into the gear boxes. Unplug the power from the source to reset controller. If the problem persists, send an email to support@apexdesk.com.

CARE INSTRUCTIONS

Recommend checking the screws and bolts several times a year to ensure they stay tight.
For all surfaces: wipe clean with a damp cloth and a weak cleaning solution, then dry with a clean and dry cloth.

TECHNICAL SPECIFICATIONS

Height Range	27.56" 45.67" (without top)
Lifting Speed	0.5" per second
Load Capacity	170 lbs
Input Power	110V, 2A, 50Hz
Duty Cycle	Max 4 min. ON / 18 min. OFF

WARRANTY INFORMATION

SCOPE OF WARRANTY

Apex Furniture LLC (“ApexDesk”) warrants to the original purchaser its new desk (except for components not warranted under “Exclusions”) manufactured by ApexDesk to be free from defects in material and workmanship under normal use and service. ApexDesk’s obligation under this warranty is limited to the repair or replacement, at ApexDesk’s sole option, of the parts or products the defect of which are reported to ApexDesk within the applicable warranty period and which, upon examination by ApexDesk, prove to be defective.

APPLICABLE WARRANTY PERIOD

The applicable warranty period, measured from the date of delivery to the original user, shall be two (2) years on motor and moving parts, five (5) years on steel frame for all warranted desks.

EXCLUSIONS

This limited warranty does not cover and ApexDesk shall not be liable for the following: (1) repairs and replacements because of misuse, abuse, negligence, alteration, accident, freight damage, or tampering; (2) products which are not installed, used, stored and properly cleaned as required in the ApexDesk “Assembly Guide” for this product; (3) products considered to be of a consumable nature; (4) Shipping to or from repair center; (5) accessories or parts not manufactured by ApexDesk; (6) charges by anyone for adjustments, repairs, replacement parts, installation, or other work performed upon or in connection with such products which is not expressly authorized in writing in advance by ApexDesk.

EXCLUSIVE REMEDY

ApexDesk’s only obligation under this warranty is the repair or replacement of defective parts. ApexDesk shall not be liable for any direct, special, indirect, incidental, exemplary, or consequential damages or delay, including, but not limited to, damages for loss of profits or loss of use.

CONTACT INFORMATION

Apex Furniture LLC (“ApexDesk”)
18467 Railroad Street
City of Industry, CA 91748
Email: support@apexdesk.com
(877) 516-DESK
www.apexdesk.com

For technical assistance, please call us or visit us at www.apexdesk.com/support.