

fig. 1

- 1 Knob
- 2 Handle Bar
- 3 LEVER
- 4 Carousel (removable)
- 5 Funnel for coffee (removable)
- 6 Operating Panel

fig 1.1

- 6a Main On/Off Switch (illuminated)
- 6b Pump On/Off Switch
- 6c Red Indicator Light (empty coffee container / tray missing)
- 6d Thermostat Light (yellow)

- 7 Selector Switch

fig 1.2

- 7a Coffee Position (spout)
- 7b Hot Water Position
- 7c Steam/Frothing Position

- 8 Frother

- 8a Cylinder (movable)
- 8b Frother Tip (removable)

- 9 Grid (removable)

- 10 Tray (removable)

fig 1.3

- 10a Tray Base
- 10b Overflow Indicator
- 10c Used Coffee Container

- 11 Measuring Scoop

- 12 Dual Coffee Spout (height-adjustable)

- 13 Tab to move spout up and down

- 14 Water Tank (removable)

- 15 Lid for Water Tank

- 16 Lid for Coffee Funnel

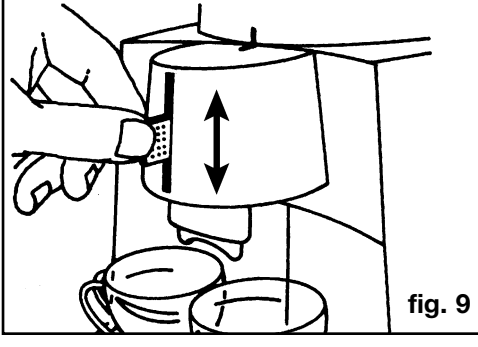
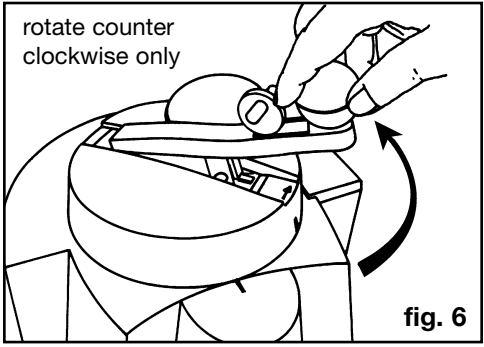
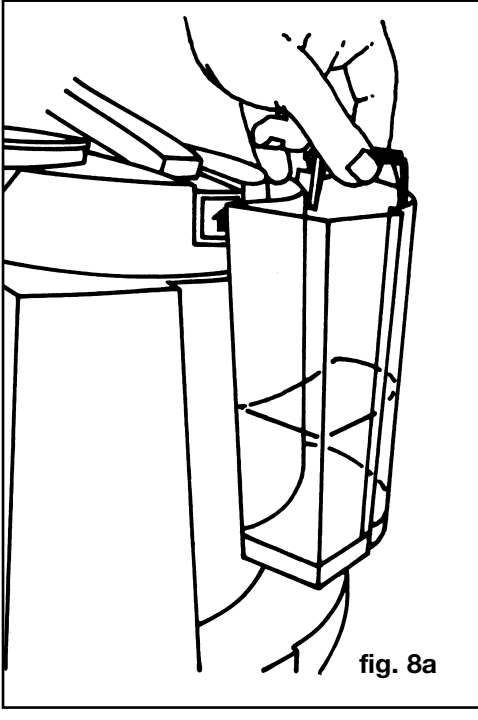
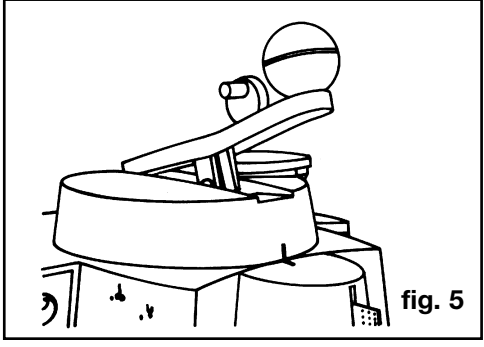
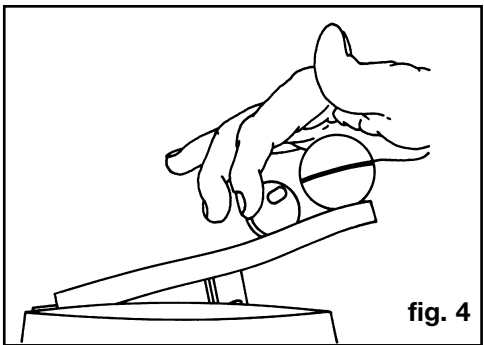
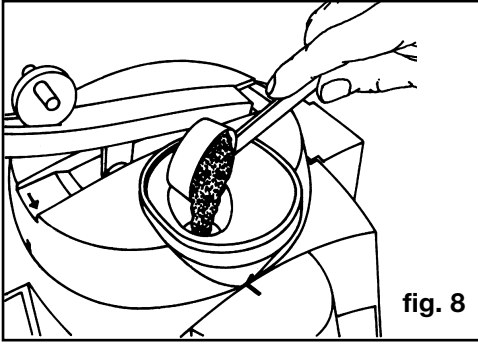
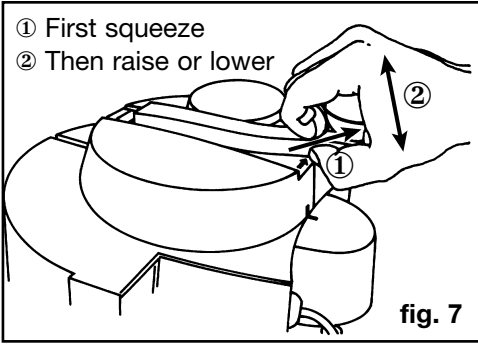
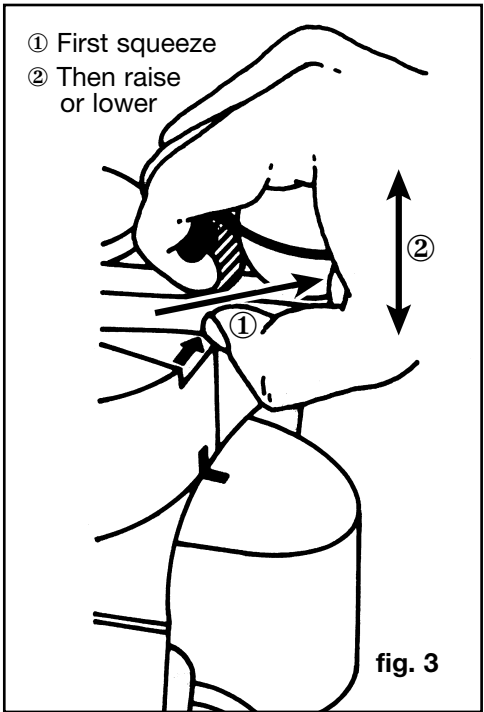

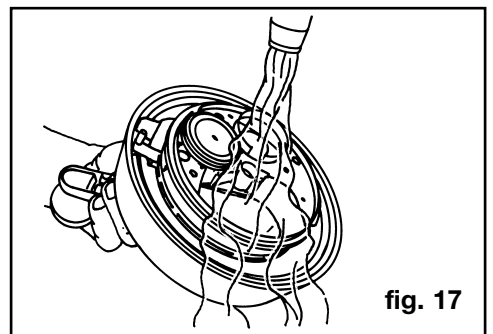
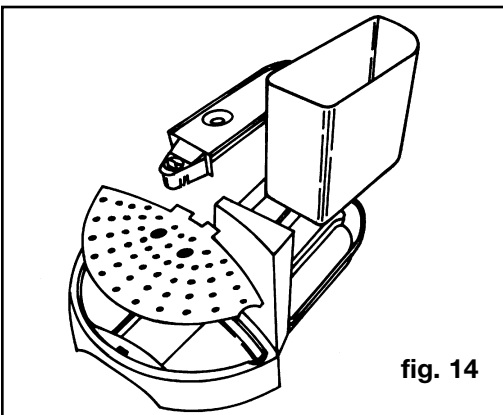
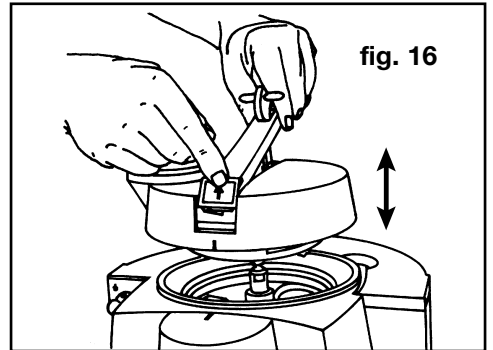
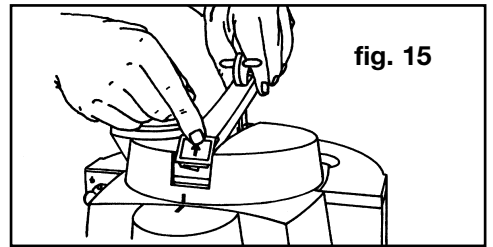
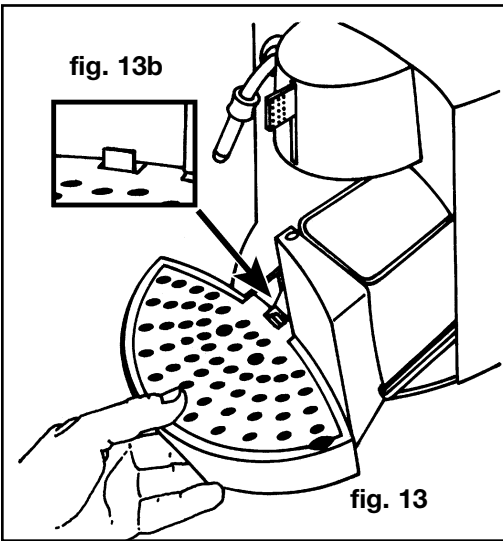
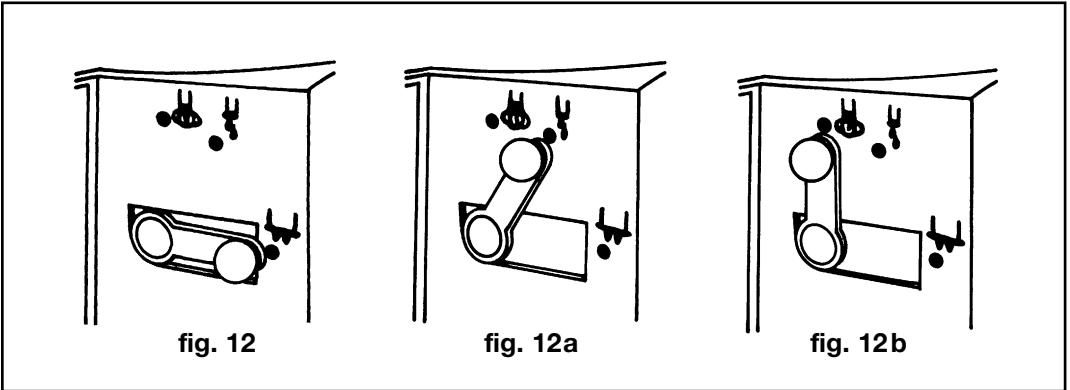
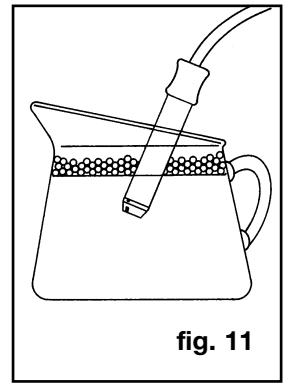
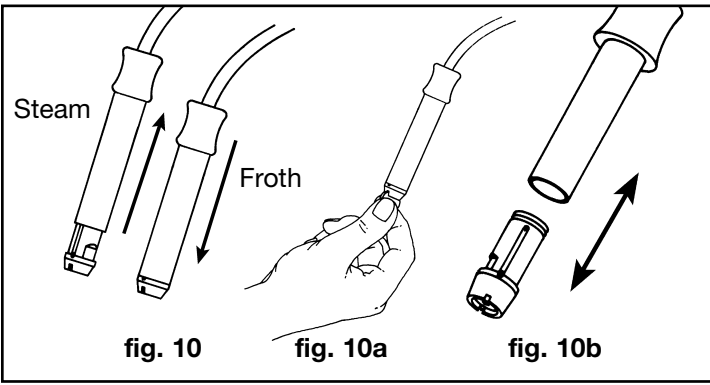

Contents

| Chapters | Page |
|---|-------------|
| 1. EQUIPMENT | 4 |
| 2. PLEASE DO NOT..... | 4 |
| 3. CAPRESSO Plus Service™ | 4 |
| 4. AFTER UNPACKING | 4 |
| 5. WORKING WITH THE CAROUSEL | 4-5 |
| 6. INITIAL PREPARATION | 5 |
| 7. HOW THE THERMOSTAT LIGHT WORKS | 5 |
| 8. WHICH COFFEE GRIND? | 5-6 |
| 9. BEVERAGES... BEVERAGES..... | 6 |
| 10. MAKING ESPRESSO | 6 |
| 11. MAKING CAPPUCCINO (frothing milk) | 7 |
| 12. MAKING CAFE LATTE (steaming milk) | 7-8 |
| 13. CLEANING THE FROTHER IMMEDIATELY | 8 |
| 14. HOT WATER SETTING..... | 8 |
| 15. CARE AND MAINTENANCE | 8 |
| 15.1 REMOVING USED COFFEE | 8 |
| 15.2 OVERFLOW WATER INDICATOR | 9 |
| 15.3 REMOVING THE CAROUSEL..... | 9 |
| 15.4 CLEARING THE THERMOCOIL..... | 9 |
| 15.5 DECALCIFYING | 9 |
| 16. WHAT IF... | 10 |
| 17. FREQUENTLY ASKED QUESTIONS | 10-11 |
| 18. LIMITED WARRANTY / Capresso Customer Service..... | 12 |
| PRODUCT REGISTRATION | back covers |

1. EQUIPMENT

The CAPRESSO "Ultima" (#121) comes with the following parts:

- Coffee Scoop
- Removable tray with grid, internal used coffee container and overflow indicator
- Removable water container with lid
- Removable coffee funnel insert with lid
- Mail Order Insert

2. PLEASE DO NOT

- Do not try to rotate the carousel (fig. 1; #4) clockwise
- Do not try to rotate the carousel with the lever (fig. 1; #3) down
- Do not try to push the lever down unless the lever points to the front
- Do not fill more than two scoops of coffee into the coffee funnel
- Do not fill coffee into the coffee funnel if the funnel is not pointing towards the front of the machine
- Do not fill anything else but ground coffee into the coffee funnel
- Do not operate the machine without the complete tray, with all its components, properly inserted into the machine
- Do not clean or decalcify the brewing chamber with any highly reactive cleaning solutions
- Do not lift the machine by the lever

3. CAPRESSO Plus Service™

- **HELP CALL 1-800-767-3554**
(Monday - Friday 9 AM to 4 PM Eastern Standard Time)
- **E-Mail address:**
contact@capresso.com
- **Fax:** 201-767-9684
- **Website:** www.capresso.com

We want you to be completely satisfied with your Capresso "Ultima". If you need any assistance, call the above number. Call anytime you want. If you get a voice mail message leave your phone number and say "model #121" or "Capresso Ultima" and tell us a good time to call you back. You can also e-mail or fax us any time.

Our unique CAPRESSO "Ultima" Plus Service" offers you the following within the first 12 months (within the United States of America):

- **Free** repair or free replacement if your Capresso Ultima malfunctions, including *shipping both ways* and convenient UPS call tag pick-up (UPS will come to you to pick up your machine, so you don't have to go to UPS or the post office).
- **Free** replacement of any defective part including free shipping. For limitations and restrictions see chapter 18, WARRANTY.

4. AFTER UNPACKING

- When unpacking your Capresso "Ultima" the lever (fig. 1; #3) is in the locked position (see fig. 2). To unlock and raise the lever first squeeze the handle bar towards the knob (see fig. 3), then lift the lever upwards and release the handle bar (see fig. 4) Now you can rotate the carousel counter clockwise (see fig. 6).
- After unpacking your machine, clean the loose parts (water container, tray with components) with a mild detergent and warm water, then rinse thoroughly.

5. WORKING WITH THE CAROUSEL

- a. The carousel only turns when the lever is in the raised position (see fig. 5)
- b. The carousel only turns counter clock wise (see fig. 6)
- c. The lever can only be pushed down when it points to the front of the machine (see fig. 5 and 7)
- d. To move the lever up or down you must always first squeeze and hold the handle bar then pull the lever up or push it down (see fig. 7). Then release the handle bar. The best way to work the handle bar is to place the palm of your hand on top of the knob and then squeeze the handle bar with two fingers towards the knob (see fig. 4 and fig. 3)

- e. When the lever is raised you can turn the carousel counter clockwise indefinitely. Just hold the knob and turn the carousel (see fig. 6)
 - f. The carousel has two positions with an audible "click":
 - lever in front of machine (see fig. 5)
 - coffee funnel in front of machine (see fig. 8) = coffee filling position
- Please practice the operation of the lever and the carousel a few times.
- i. Turn the Pump Button on (see fig. 1.1; #6b). You will hear a pump noise. Initially it will take about 30 to 40 seconds before any water will come out of the spout. As soon as some water comes out of the spout, turn the pump button off.
 - j. Raise the lever (see fig. 7) and slowly turn the carousel counter clockwise (see fig. 6) until the coffee funnel points to the front of the machine (see fig. 8)

You are now ready to prepare your favorite coffee beverage.

6. INITIAL PREPARATION

This procedure is necessary before first use and after you have cleared the machine (see CLEARING THE THERMOCOIL, chapter 15.4).

- a. Plug in the machine. (The machine has an internal cord storage. Just pull out as much cord as you need. You can push the unwanted part of the cord back into the machine).
- b. Remove the water tank lid, lift out the water tank, and fill with cold, fresh water. Replace the water tank and make sure it sits properly in its receptacle (see fig. 8a). The water tank holds approx. 53 oz. You can also use another container and fill the water tank without removing it from the machine.
- c. Make sure the selector switch points to the coffee spout symbol (see fig. 12)
- d. Make sure the tray is inserted properly (see fig. 2).
- e. Make sure the lever points to the front (see fig. 5)
- f. Close the lever as follows: First squeeze and hold the handle bar then push the lever down (see fig. 7). Now release the handle bar.
- g. Switch on the Main On/Off Button (see fig. 1.1; #6a). The red light within the On/Off button will illuminate. At the same time the yellow Thermostat Light will light up indicating that the machine is heating up the internal ThermoCoil unit.
- h. Place a cup underneath the coffee spout.

7. HOW THE THERMOSTAT LIGHT WORKS

- As long as the yellow Thermostat light (fig. 1.1; #6d) is on, the ThermoCoil inside the machine is heating up. When the selector switch is in the spout position (fig. 12) or in the hot water position (fig. 12a) the thermostat light will turn off when the maximum temperature is reached. While brewing coffee, the thermostat light might come on, indicating that the ThermoCoil is heating up again .
For hottest coffee: When you turn on the pump just after the thermostat light turned off, you will get the highest possible coffee temperature.
- When the selector switch is in the steam position (fig. 12b), the thermostat light will stay on, indicating that the internal temperature is now higher to transform hot water into steam.

8. WHICH COFFEE GRIND?

The Capresso Ultima works with a variety of grinds. It is much less sensitive to the coffee grind than most other pump espresso machines. You can even grind with a regular blade grinder and still get crema espresso coffee. The coarser the coffee, the faster the water will run through, resulting in a weaker taste. The finer the coffee is ground, the slower the coffee will pump through, resulting in a stronger, hotter cup of espresso. If

no or hardly any coffee comes out of the spout, then your coffee is ground too fine.

9. BEVERAGES... BEVERAGES...

The Capresso "Ultima" lets you produce the following beverages:

- **Espresso** (coffee spout)
1 to 1 1/2 oz. per cup; make one or two cups at a time. Some people make the espresso a bit larger. Serve with or without sugar. Use one or two scoops of coffee to your liking. Espresso is the foundation for Cappuccino, Cafe Latte and Cafe Americano.
- **Crema Coffee** (coffee spout)
4 to 6 oz. per cup; make one or two cups at a time. Use one or two scoops of coffee to your liking. Essentially "Crema Coffee" is a longer brewed espresso with slightly more extraction. In Europe more and more people switch from drip coffee to crema coffee.
- **Cappuccino** (coffee spout + frother in frothing position)
Espresso plus hot milk plus milk froth. Normally you add two to three parts of milk and milk froth to one part of espresso. Serve with chocolate shaving, cinnamon, sugar... anyway you like it. Some people use less milk to taste more coffee.
- **Cafe Latte** (coffee spout + frother in steaming position)
Espresso plus steamed milk with no or very little milk froth. Add steamed milk (3 to 5 oz.) to one espresso.
- **Cafe Americano** ("Cafe Lungo") (coffee spout + frother)
Espresso plus hot water. Add 3 to 5 oz. of hot water to your espresso (use the hot water setting of the frother). The difference between Crema Coffee and Cafe Americano is the shorter extraction time for the coffee, resulting in a somewhat different taste.
- **Tea** (frother)
Insert tea bag into a tea cup and add hot water with the frother in the hot water setting.

- **Hot Chocolate** (frother)

Instant: Pour powder into a glass and add hot water with the frother. Regular (with milk): Steam the milk with the frother, add powder and stir.

10. MAKING ESPRESSO

- a. Make sure the coffee funnel points to the front of the machine (fig. 8)
- b. Remove the funnel lid, if it still sits on top of the coffee funnel (fig. 1; #16)
- c. Fill one or two level scoops of ground espresso coffee into the funnel (fig. 8)
Attention: If you fill more than two scoops of coffee into the funnel, the carousel will automatically discard the excess coffee into the internal used coffee container. If you fill less than one level scoop of coffee into the funnel, the coffee will not be tamped properly resulting in a poor cup of espresso.
- d. Turn the lever a quarter turn until it points to the front of the machine (fig. 5)
- e. Close the lever (see fig. 7). When you feel resistance, release the handle bar. The lever will automatically tamp and lock in place.
Important: With two scoops of coffee in the brewing chamber, the lever will not go down as far as it does with no coffee in the chamber. Do not force the lever down beyond the point of resistance.
- f. Place one or two cups underneath the coffee spout and adjust the spout so that it is as close as possible to the rim of the cup(s) (see fig. 9).
- g. Make sure the selector switch points to the coffee spout symbol (see fig. 12)
- h. Turn the pump button on.
- i. When you have enough espresso in your cup(s), turn the pump off.
- j. Serve with or without sugar. (If you fill sugar into your espresso cups before brewing, it will dissolve as the espresso brews into the cups.)

- k. Raise the lever and turn the knob counter clockwise until the funnel is in front of the machine again (fig 8). You are now ready to make more espresso. (While turning the carousel the used coffee is automatically thrown into the internal used coffee container).

11. MAKING CAPPUCCINO (frothing milk)

Attention: When using the frother in the steam position, never turn on the pump.

Which kind of MILK? Always start with cold milk. Skim milk (0% fat) will produce the most froth and will let you taste "more" of the espresso. 1% or 2% milk will give you almost as much froth as skim milk. Regular milk (3% fat) will produce half the froth of skim milk and will taste very rich.

Frothing

Tip: For a novice it is easier to froth with a bit more milk. You will not waste any milk since you can re-use it again later. With practice you will be able to froth small amounts of milk.

- a. Use a 12 oz. or 16 oz. pitcher.
- b. Fill the pitcher with 6 to 8 oz. of cold milk (this will yield enough hot milk and froth for two to three cups of cappuccino).
- c. Place the pitcher next to the frother.
- d. Prepare your espresso as described above (you might want to brew the espresso directly into your cappuccino cups.) Turn the pump switch off and wait until the yellow thermostat light turns off.
- e. Now immerse the frother into the pitcher (with the cylinder pushed down) (see fig. 10) with the tip of the frother completely immersed in the milk (see fig. 11). The frother should not touch the bottom of the pitcher.
- f. Now turn the selector switch to the steam symbol (fig. 12b). Frothing

will start within 10 seconds. After 40 to 60 seconds you should have plenty of froth and hot milk. To stop frothing, turn the selector switch back to the spout symbol, then remove the pitcher and set it aside for a few seconds for the froth to settle.

Tip: If you like your milk extra hot, first steam the milk for about 10 to 15 seconds by pulling the cylinder of the frother up (see fig. 10), then push it down and frothing starts immediately.

Caution: If the milk starts boiling, immediately stop frothing by turning the selector switch back to the spout symbol (fig 12.) Boiling milk will not produce any froth. Next time use more cold milk to avoid boiling.

Not enough steam?

The steam output will stop abruptly after 80 to 90 seconds. If you need more steam at this time proceed as follows:

- Make sure the lever is in the closed position.
- Turn the selector switch to the spout symbol and turn the pump on.
- As soon as some water comes out of the spout, turn the pump switch off again. This will take only 15 to 20 seconds.
- When you then turn the selector switch to the steam symbol, you will have 80 to 90 seconds of uninterrupted steam again.

12. MAKING CAFE LATTE (steaming milk)

Attention: When using the frother in the steam position, never turn on the pump.

Follow the steps for espresso and cappuccino above. Since you do not want to froth the milk, just make sure that the cylinder of the frother is moved up (see fig. 10).

Attention: The steaming noise will increase as the milk gets hotter. Stop steaming before the milk starts boiling. Always remember to turn the

selector switch back to the spout symbol.

13. CLEANING THE FROTHER IMMEDIATELY

If you clean the frother immediately after frothing, it will be faster and easier than at a later time, when the milk has hardened around the tip.

- a. Immediately after you stop steaming or frothing, set the milk pitcher aside and hold the bottom of the coffee scoop against the tip of the frother.
- b. Turn the selector switch to the steam symbol for two seconds. Steam will come out of the small side holes.
- c. Turn the selector switch back to the spout symbol. Repeat once or twice. This will push out any milk which might have accumulated in the frother.
- d. Now move the cylinder up and wipe it clean with a small sponge or wet cloth.

Taking The Frother Apart

Periodically take the frother apart and clean thoroughly.

- Loosen the tip of the frother with a coin and then unscrew the tip (see fig. 10a).
- Pull the tip out of the cylinder (see fig. 10b).
- Clean the steam hole and the two side holes. Make sure all holes are free of milk deposits. If hardened milk sits in these holes, use a tooth pick or a paper clip to push out the milk deposits.
- Replace the frother and screw on finger tight.

14. HOT WATER SETTING

When you turn the selector switch to the hot water setting (see fig. 12 a) and turn the pump button on, hot water will be released through the frother immediately. This feature can be used to make a quick cup of tea,

instant hot chocolate, cafe americano or simply get some hot water. When finished, turn off of the pump button first. Then turn the selector switch back to the spout symbol (fig. 12).

15. CARE AND MAINTENANCE

Your Capresso "Ultima" requires less care than most traditional espresso pump machines. If you follow the instructions below you will prolong the life of the machine for many years.

15.1 REMOVING USED COFFEE

The red indicator light (see fig. 1.1; #6c) will come on in the following situations:

- When it is time to empty the used coffee container (fig. 1.3; #10c) or
 - Whenever the tray is pulled out or not inserted properly.
- a. Remove the tray (fig. 13) and remove the three loose parts (overflow indicator, grid and used coffee container).
 - b. Now empty and clean the used coffee container.
 - c. Remove any water from the tray and clean the tray.
 - d. Place all the parts back into the tray and insert tray back into the machine.

Now the red indicator light will turn off.

Caution: The red indicator light will not interrupt any operations of the machine. Therefore, if you do not empty the used coffee container and continue to make coffee beverages, used coffee will spill into the inner parts of the machine eventually blocking the carousel. Also, if the tray is not inserted and you make coffee, water and used coffee will be discarded into the open area inside the machine **creating a big mess!**

Attention: The tray can only be pulled out when the coffee spout is moved all the way up (see fig. 13).

15.2 OVERFLOW WATER INDICATOR (fig. 13b)

After brewing coffee, the machine automatically releases the pressure of the brewing chamber together with some water into the tray. If too much water collects in the tray the little red indicator will pop up. Pull out the tray, remove the used coffee container and the water level indicator. Then empty tray and the used coffee container, place all the parts back into the tray, and insert tray back into the machine.

15.3 REMOVING THE CAROUSEL

For proper cleaning you can remove the carousel as follows:

- a. The lever should be in the raised position.
- b. Turn the lever to the back of the machine so that the carousel release button points to the front (see fig. 15).
- c. Push the button and lift the carousel (see fig. 16).
- d. Hold the carousel upside down and clean under running water (see fig. 17).
- e. Replace the carousel in reverse order. Make sure that the release button points to the front of the machine. Make sure that the lever is in the raised position before placing the carousel back onto the machine.

DO NOT PLACE THE CAROUSEL IN THE DISHWASHER!

15.4 CLEARING THE THERMOCOIL

The internal ThermoCoil system holds a small amount of water. If you do not use the machine for a prolonged time (a week or longer) or if you plan to move the machine or send it to another place the ThermoCoil should be empty. This procedure takes approximately 90 seconds.

- a. Turn the machine on.
- b. Fill a large pitcher with cold water and immerse frother into pitcher.
- c. Turn the selector switch to the steam symbol. Steam will be

released for about 80 seconds.

When the steam stops, the ThermoCoil system is cleared.

- d. Turn the selector switch back the spout symbol and turn machine off.

Important: The next time you use the machine, follow the instructions under chapter 6 first.

15.5 DECALCIFYING

CAUTION: DO NOT USE ANY COMMERCIAL DECALCIFYING AGENT. DO NOT USE DURGOL. Any highly re-active cleaning solution might destroy the internal brewing chamber. Use a water/vinegar solution only.

If you use your machine daily we recommend decalcifying every 4 to 6 weeks as follows. This procedure will take about 15 minutes.

- a. Fill the water tank with 20 oz. of water and approx. 10 oz. of vinegar.
- b. Turn the machine on and place a large cup or container underneath the coffee spout.
- c. Pump approx. 5 oz. of the solution through the coffee spout.
- d. Stop the pump, wait for one minute.
- e. Repeat three of four times.
- f. Then place a large container underneath the frother.
- g. Turn the selector switch to the hot water symbol and turn on the pump.
- h. Pump approx. 3 oz. of the solution through the frother.
- i. Stop the pump, wait for one minute.
- j. Repeat twice.
- k. Now empty the water container and clean it thoroughly so that there is no vinegar residue left in the water container.
- l. Fill the water container half full with fresh cold water.
- m. Pump half of the water through the coffee spout and the other half through the frother using the hot water setting.
- n. Turn off the machine. Remove tray and clean all parts of the tray.

16. WHAT IF

a. No water comes through the coffee spout

- Make sure the water tank is inserted properly and water is in the water tank.
- Make sure the lever points towards the front of the machine and is in the closed position.
- Make sure the selector switch points to the spout symbol.
- Coffee is ground too fine; use coarser ground coffee.

b. My coffee is not hot enough

- Pre-warm your cups.
- Pump some hot water through the coffee spout (see chapter 6).
- Turn on the pump just after the thermostat light turns off.
- Use finer ground coffee.
- Drink your coffee right away.

c. Coffee does not flow into both cups at the same rate

You should get at least a 40%/60% distribution.

- Pump hot water without coffee through the coffee spout (see chapter 6).
- Remove carousel and clean thoroughly (chapter 15.3).
- Make sure you fill enough coffee into the coffee funnel.

d. Coffee trickles very slowly into the cups

- Your coffee is ground too fine. Use a somewhat coarser grind.

e. Coffee runs very fast into the cups with very little crema

- Your coffee is ground too coarse. Use a finer grind.
- Use a bit more coffee.

f. There is some coffee residue in the bottom of my cup

- With pressure brewed coffee you will always have some fine coffee powder in the bottom of your cup.

g. When I use the frother I cannot get sufficient froth

- Make sure you follow the instructions in chapter 11.
- If the frother worked before, the frother is probably clogged. Clean frother, see chapter 13.
- Make sure that the pump is turned off, when the selector switch is pointed to the steam symbol.
- Try a different kind of milk.

17. FREQUENTLY ASKED QUESTIONS

a. Can I use flavored coffee?

Very often flavored coffee has natural or artificial sugar additives. Hardened sugar deposits can clog and damage the internal brewing chamber. You can still use flavored coffee provided you run a hot water cycle through the coffee spout within half an hour after your prepared your flavored coffee drink. Proceed as described in chapter 6 and let approx. 4 to 5 oz. of hot water run through the coffee spout.

b. Can I fill anything else into the coffee funnel, e.g. sugar, cinnamon, chocolate shavings?

No!

c. Can I fill anything else into the water tank instead of water, e.g. milk, sweetened water?

No, you will destroy the pump and the ThermoCoil system. Exception: see chapter 15.5 Decalcifying.

d. Can I use the same coffee for espresso and for "crema coffee"?

Yes, when you brew longer ("crema coffee") the taste will be less intense.

e. Can I use coffee which is not labeled "espresso"?

Yes.

f. Can I use the machine overseas with a converter?

No. The machine is designed for 120 volts / 60 Hz. Other voltage and Hz levels might damage the machine.

g. Can I send a machine to another country with 120 volt / 60 Hz configuration.

Yes, but in case the machine needs service the transportation costs have to be paid by you. Our warranty is limited to the United States of America.

h. I have a small grinder with a blade. Can I use this grinder to grind my coffee for this machine?

Yes. We have tested several "blade grinders". The results are satisfactory. However with a burr grinder you will get better results; the crema will be thicker.

i. How long can I leave the machine on?

When you are finished using the machine, it should be turned off. If you need the machine again within an hour or so, the heat-up time will be less than 50 seconds.