

# SC4.18™

## Radio Controlled Truck



*Thank you for purchasing  
the Dromida SC4.18!*

### CARE AND MAINTENANCE

- Before each run, examine all parts for damage. If any is found, do not operate until the damage has been repaired.
- Use a clean cloth to wipe the vehicle clean.
- Keep the vehicle and batteries away from direct sunlight and/or heat sources.
- Visit [dromida.com](http://dromida.com) for repair guides and replacement parts.

### SAFETY PRECAUTIONS

**Warning: Do not modify or alter this model.** Changes or modifications to this model not expressly approved by the party responsible for compliance could void the user's authority to operate the equipment.

- The vehicle is suitable for ages 14 and above. Parents should supervise children who operate the vehicle.
- This vehicle is suitable for indoor or outdoor use.
- Switch off the vehicle and disconnect the battery when it is not in use.
- Keep hands, face and loose clothing away from the vehicle.
- Always follow these instructions when operating this vehicle.
- Do not operate near people or animals.
- Always unplug the battery from the charger after charging is complete.

### BATTERY CAUTIONS

- Parental guidance is recommended when installing or replacing batteries.
- Insert new batteries in the radio as soon as any function becomes diminished.

**The vehicle is equipped with a NiMH battery. Always follow these safety instructions:**

- Never dispose of batteries in a fire or store near sources of heat. Batteries must be discharged before being recycled. Cover exposed poles with adhesive tape to prevent short-circuiting!
- Always use the included "charge monitor" when charging your battery. The charger is specially designed for charging the battery of this car. Only use it for this purpose.
- Batteries should only be charged on a fireproof surface, away from any flammable materials.
- Never leave the battery unattended when charging.
- Never disassemble or alter the battery contacts. Do not damage or puncture battery cells. Doing so would result in an explosion hazard!
- Keep the NiMH battery away from children.



This product contains a NiMH battery. Must be recycled or disposed of properly.

**WARNING:** This product contains a chemical known to the State of California to cause cancer.

### 90 DAY LIMITED WARRANTY

**PLEASE DO NOT RETURN YOUR PRODUCT TO THE STORE!** Dromida will repair or replace factory defects for 90 days from the date of purchase. This warranty specifically does not cover crash damage, misuse or abuse. To make a warranty claim, please contact our product support team at 1-217-398-8970 or e-mail us at [productsupport@hobbico.com](mailto:productsupport@hobbico.com).

If requested by Product Support, please send defective product to: Hobby Services, 3002 N Apollo Dr., Suite #1, Champaign, IL 61822.

This warranty applies only if the product is operated in compliance with the instructions and warnings provided with each model. Dromida assumes no liability except for the exclusive remedy or repair of parts as specified above. Dromida shall not be liable for consequential or incidental damages. Some states do not allow the exclusion of consequential or incidental damages so the above exclusion may not apply to you. This warranty gives you specific legal rights and you may also have other rights which vary from state to state.

## VEHICLE AND RADIO PARTS

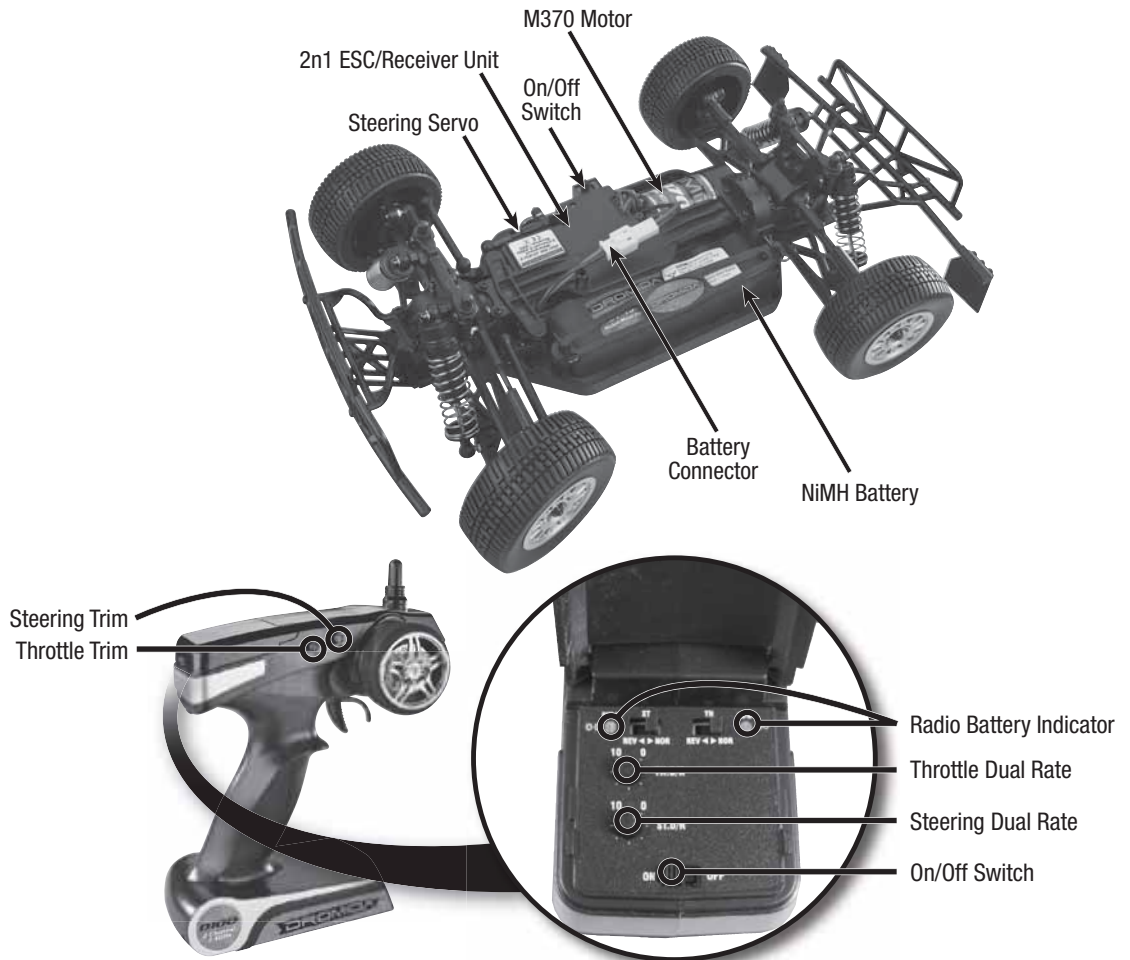

## BATTERIES

### Radio:



Insert 4 "AA" batteries into the bottom of the radio.

### Vehicle:

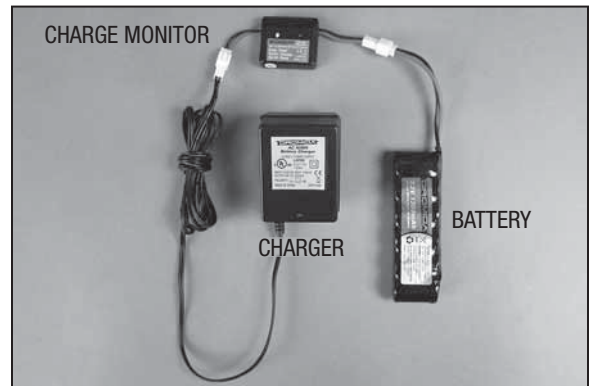

1. Switch off the vehicle and remove the battery.
2. Carefully connect the battery to the charge monitor.
3. Plug the monitor into the charger and the charger into an AC wall outlet.
4. The charging process takes approximately 4 hours. Unplug the battery when charge is complete. **WARNING:** Never leave the charging battery unattended!

### CHARGE MONITOR LED INDICATORS

<b>GREEN</b>	Power ("ON" at all times)
<b>RED "ON"</b>	Battery is charging
<b>RED "OFF"</b>	Charging is complete

## DRIVING THE VEHICLE



1. Install the battery into the vehicle and connect the battery.
2. Secure battery strap to post using clips.



3. Switch radio on.

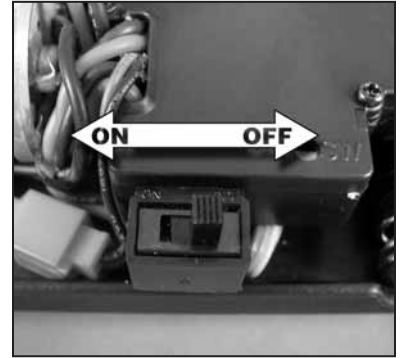

4. Switch vehicle on.



- To slowly drive forward, pull the trigger slightly. To drive faster, pull the trigger further.
- To brake, push the trigger. To drive in reverse, push again.
- During a crash, release the trigger.
- To turn, rotate the wheel to the left or right.
- Adjust the steering trim if the car doesn't track straight (see below).
- When the vehicle battery becomes low, the vehicle will start to slow down.
- Allow the battery to cool before recharging.
- Make sure to turn both the vehicle and the radio off after each use.
- ALWAYS unplug the battery after each use.

## TRIMS AND DUAL RATES



### Throttle Trim

- If the vehicle rolls forward without throttle input, rotate the throttle trim knob slightly left.
- If the vehicle rolls backwards without throttle input, rotate the throttle trim knob slightly right.

### Steering Trim

- If the vehicle tracks right (when viewed from behind), rotate the steering trim knob slightly left.
- If the vehicle tracks left (when viewed from behind), rotate the steering trim knob slightly right.
- Check that the servo saver screw is fully tightened to ensure that your vehicle tracks straight.

### Throttle Dual Rate

- If you need to limit the maximum speed of your vehicle, rotate the "TH.D/R" knob counterclockwise. For higher top speeds, rotate the knob clockwise.

### Steering Dual Rate

- If you need to limit the amount of steering your vehicle has, rotate the "ST.D/R" knob counterclockwise. For more steering, rotate the knob clockwise.

**NOTE:** We recommend limiting the vehicle's maximum speed for beginners and gradually increasing the top speed once you become more comfortable with the controls.



## DRIVING TIPS

- Always release the throttle trigger right away following a crash to prevent damaging the electronics.
- The vehicle should be operated in an open space with no people or animals nearby.
- Do not operate this vehicle on the street.

## LINKING PROCEDURE

To link the radio to the receiver:

1. Turn on the radio, then turn on the vehicle.
2. Press the "SW" button on the 2n1 ESC/Receiver unit and release. The ESC should beep, notifying you it is linked.
3. Process is complete.

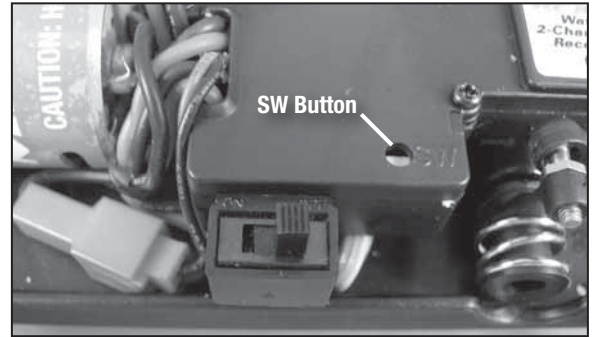

## REPLACEMENT AND OPTION PARTS

For repair information or a complete list of replacement and option parts, visit [dromida.com](http://dromida.com).

## SERVICE

If your vehicle requires repairs or replacement, contact:

Hobby Services  
3002 N. Apollo Drive, Suite 1  
Champaign, IL, 61822, U.S.A.

9am-5pm Central Mon.-Fri.  
(217) 398-0007  
[hobbyservices@hobbico.com](mailto:hobbyservices@hobbico.com)

## FCC STATEMENT

This device complies with part 15 of the FCC rules. Operation is subject to the following two conditions.

- (1) This device may not cause harmful interference.
- (2) This device must accept any interference received, including interference that may cause undesired operation.

**NOTE:** THE MANUFACTURER IS NOT RESPONSIBLE FOR ANY RADIO OR TV INTERFERENCE CAUSED BY UNAUTHORIZED MODIFICATIONS TO THIS EQUIPMENT.

Any changes or modifications not expressly approved by the party responsible for compliance could void the user's authority to operate the equipment.

This equipment complies with FCC radiation exposure limits set forth for an uncontrolled environment. This equipment should be installed and operated with a minimum distance of 20cm between the radiator (transmitter) and your body. This transmitter must not be co-located or operating in conjunction with any other antenna or transmitter.

## CE COMPLIANCE INFORMATION FOR THE EUROPEAN UNION

### INSTRUCTIONS FOR DISPOSAL OF WASTE EQUIPMENT BY PRIVATE USERS IN THE EUROPEAN UNION:

This symbol on the product or its packaging indicates this product must not be disposed of with other household waste. Instead, it is the user's responsibility to dispose of their waste equipment by handing it over to a designated collection point for the recycling of waste electrical and electronic equipment. The separate collection and recycling of your waste equipment at the time of disposal will help to conserve natural resources and ensure that it is recycled in a manner that protects human health and the environment. For more information about where you can drop off your waste equipment for recycling, please contact your local city office, your household waste disposal service or location where you purchased the product.



### DECLARATION OF CONFORMITY:

Product: Dromida D100 2.4GHz 2-Channel Pistol Transmitter/RE18 2n1 RX/ESC  
Item number: DIDJ1000/DIDM1000  
Equipment class: 1



Dromida  
c/o Hobbico, Inc.  
2904 Research Road  
Champaign, IL USA 61826

### DROMIDA D100 TRANSMITTER AND DROMIDA RE18 2N1 RECEIVER/SPEED CONTROL:

The objects of the declaration described here are in conformity with the requirements of the specifications listed below, following the provisions of the European 2006/95/EC Low Voltage Directive:

EN 60950-1:2006+A11:2009+A1:2010+A12:2011  
EN 62311:2008

The objects of the declaration described here are in conformity with the requirements of the specifications listed below, following the provisions of the European R&TTE directive 1995/5/EC:

ETSI EN 301 489-1 V1.9.2 (2011-09) ETSI EN 300 440-1 V1.6.1 (2010-08)  
ETSI EN 301 489-3 V1.4.1 (2002-08) ETSI EN 300 440-2 V1.4.1 (2010-08)

### CE COMPLIANCE INFORMATION FOR THE EUROPEAN UNION

The associated regulatory agencies of the following countries recognize the noted certifications for this product as authorized for sale and use.

UK	NL	SI	LT	BG
EE	DE	LU	AT	PL
RO	LV	DK	MT	IT
CY	ES	SK	HU	
SE	GR	PT	IE	
CZ	FI			