

SHGS31-1000GS-2
SHGS31-500GS-2
SHGS31-250GS-2

Product Information Datasheet

2.5” Standard SSD

Gold S31 Series Product Specification

- **Capacity**
 - 250/500GB, 1TB
- **Form Factor**
 - STD 2.5"
- **NAND Technology**
 - 3D V4
- **Sequential Performance¹⁾**
 - Read : Up to 560 MB/s
 - Write : Up to 525 MB/s
- **Random Performance²⁾**
 - Read : Up to 95K IOPS
 - Write : Up to 87K IOPS
- **Power Consumption (Typ.)**
 - Active read : 2.0W
 - Active write : 2.4W³⁾
- **Temperature Range Operating⁴⁾**
 - 0°C to 70°C (SMART Attribute ID 194)
- **Shock**
 - Operating : 1500G, duration 0.5ms
 - Non-Operating : 1500G, duration 0.5ms
- **Vibration**
 - Operating : 20G, 10~2KHz (Frequency)
 - Non-Operating : 20G, 10~2KHz (Frequency)
- **Reliability**
 - MTBF : 1.5M hours
 - BER : 1 error in 10¹⁵ bits transferred
- **Dimension**
 - (69.85±0.25) x (100±0.25) x (7+0.2/-0.5) mm
- **Weight**
 - 250/500GB, 1TB : 61g±5%
- **Voltage**
 - 5V±5%

1) Measured using IOMeter2006 with queue depth 32. Set to 128KB alignment. System variations may affect measured results.

2) Measured using IOMeter2006 with queue depth 32. Set to 4KB alignment. System variations may affect measured results.

3) Active Write power is measured with 1TB capacity

4) Tc is measured at the surface of Module center through Temp sensor. Active airflow is recommended within the system for maintaining the device operating temperature.

1.0 Product Specification

1.1 Drive Capacity

Capacity	No. of LBA
250GB	500,118,192
500GB	1,000,215,216
1TB	2,000,409,264

- Notes**
- 1) Sector Size : 512 Bytes
 - 2) User-addressable LBA count = (97696368) + (1953504 x(Desired Capacity in Gbytes-50.0))
From IDEMA (LBA1-03_standard.doc)

1.2 Performance

Specification ¹⁾	250GB	500GB	1TB
Sequential Read ²⁾ (up to)	560 MB/s	560 MB/s	560 MB/s
Sequential Write ²⁾ (up to)	500 MB/s	525 MB/s	525 MB/s
Random Read ³⁾ (up to)	54K IOPS	90K IOPS	95K IOPS
Random write ³⁾ (up to)	87K IOPS	87K IOPS	87K IOPS

- Notes**
- 1) Performance measured using IOmeter2006 with a queue depth set to 32. Measurements are performed on 1GB of Logical Block Address (LBA) range. 1MB/sec = 1,000,000 bytes/sec was used in sequential performance System variations may affect measured results. (Test Pre-condition : Secure erased and NTFS format)
 - 2) Set to 128KB alignment
 - 3) Set to 4KB alignment

1.3 Latency Specifications

Status	250GB	500GB	1TB
Read Latency (Typical)	123us	123us	107us
Write Latency (Typical)	33us		

- Notes**
- 1) Device measured by IOmeter 2006 with Queue Depth 32 workload.
 - 2) Read/Write latency measured on Random 4K transfers.
 - 3) System variations may affect measured results. (Test Pre-condition : Secure erased and NTFS format)

1.4 Power on Ready Time

Status	250GB	500GB	1TB
POR		<0.5 sec	
SPOR		<10 sec	

- Notes**
- 1) Power on ready time is measured from the time the SSD is powered-on to the time the SSD is ready to accept the first command from the host.
 - 2) Power on ready time performance measured using drive master.
 - 3) Get average value of power on to device ready time 30times at POR or SPOR.

1.5 Supply Voltage

Item	Operating Voltage
Allowable voltage	5V ± 5%
Allowable noise/ripple	100mV p-p or less

1.6 Power Consumption

Status	250GB	500GB	1TB
Active Read ¹⁾ (Typical)	1.6W	2.0W	2.0W
Active Write ¹⁾ (Typical)	1.4W	2.0W	2.4W
Idle ²⁾ (Typical)	100mW		

- Notes**
- 1) Active power is measured during execution of sequential read/write 128KB with queue depth 32.
 - 2) DIPM enable (Device Initiated Power Management)

1.7 Environmental Specification

Item	Mode	Min	Max	Unit
Temperature Ranges	Operating	0	70	°C
	Non- Operating	-40	95	°C
Humidity	Non- Operating	5	85	%
Item	Mode	Condition		
Shock	Operating	400G, 11ms / 1000G, 1ms		
	Non- Operating	500G, 2ms / 1500G, 0.5ms		
Vibration	Operating	2G, 10~3KHz, 30min/axis, Random, 3.6G, 10~3KHz, 10min/axis		

- Notes**
- 1) Measured w/o condensation.
 - 2) Operating mode is measured by temperature sensor, SMART Attributes Bytes 02:01h.
 - 3) Shock specification assumes that the SSD is mounted security with the input Vibration applied to the drive mounting screws. Stimulus may be applied in the X, Y or Z axis.
 - 4) Vibration specification assumes that the SSD is mounted security with the input Vibration applied to the drive mounting screws. Stimulus may be applied in the X, Y or Z axis. The measured specification is in root mean SQ. form.
 - 5) Operating Temperature Ranges is measured at the surface of Module center through Temp sensor. Active airflow is recommended within the system for maintaining the device operating temperature.

1.8 Reliability

Item	Description	Value
Mean Time Between Failures (MTBF)	1.5M Mean Time Between Failures is estimated based on population statistics not relevant to individual units through Reliability demonstration Test (RDT).	1.5M
Bit Error Rate (BER)	Bit error rate will not exceed one sector in the specified number of bits read. In the unlikely event of a read error, the SSD will report it as a read failure to the host; the sector in error is considered corrupt and is not returned to the host.	1 error in 10 ¹⁵ bits transferred

- Notes** The SSD incorporate advanced technology for defect and error management, they use various combinations of hardware-based error correction algorithms and firmware based static and dynamic wear-leveling algorithms.

2.0 Mechanical Specification

2.1 Physical Dimension and Weight

Model	Height(mm)	Width(mm)	Length(mm)	Weight(g)
250GB	7+0.2/-0.5	69.85±0.15	100±0.15	52.4g±5%
500GB				
1000GB				

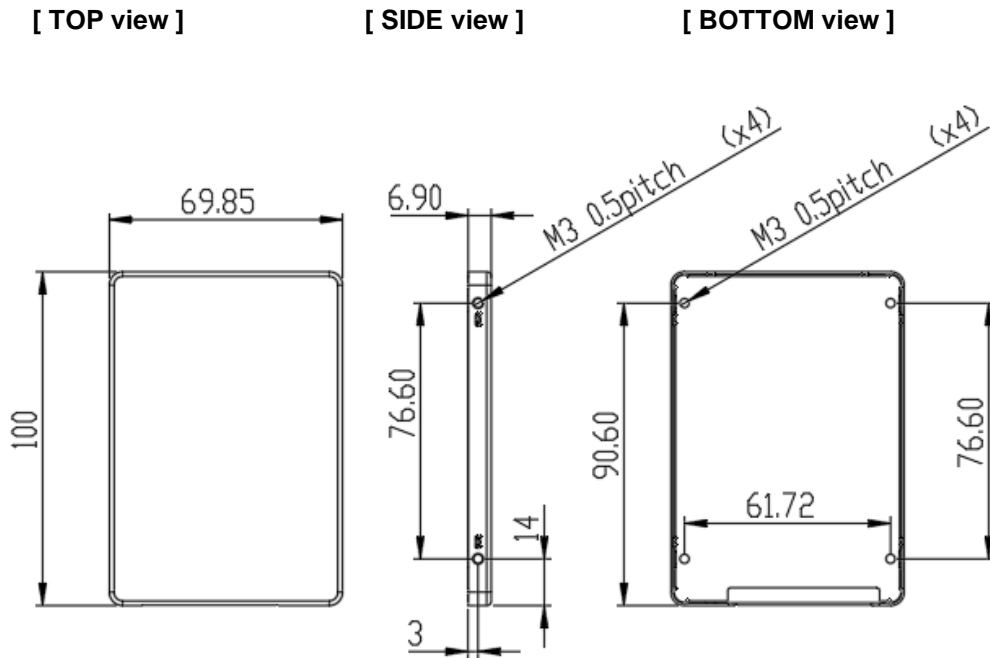

Figure 1 . Physical Dimension (Unit Diagram)

3.0 Electrical Interface Specification

3.1 Connector Pin Location

Pin	Function	Pin Definition
S1	Ground	Ground
S2	A+	Differential signal pair A and A-
S3	A-	
S4	Ground	Ground
S5	B-	Differential signal pair B and B-
S6	B+	
S7	Ground	Ground

3.2 Power Pin Location

Pin	Name	Pin Definition
P1	V33	3.3 V Power; not used
P2	V33	3.3 V Power; not used
P3	DEVSLP	SATA PHY Power Control, not used
P4	GND	Ground
P5	GND	Ground
P6	GND	Ground
P7	V5	5 V Power, Precharge
P8	V5	5 V Power
P9	V5	5 V Power
P10	GND	Ground
P11	DAS	Device Activity Signal, not used
P12	GND	Ground
P13	V12	12 V Power; not used
P14	V12	12 V Power; not used
P15	V12	12 V Power; not used

4.0 Supported ATA Command List

The SK hynix SSD complies with ATA-8/ACS-3. All mandatory and many optional commands and features are supported.

4.1 ATA Feature Set

Feature Set	Support
48-Bit Address feature set	YES
General feature set	YES
Native Command Queuing(NCQ) feature set	YES
Power Management feature set	YES
Security feature set	YES
S.M.A.R.T feature set	YES

4.2 ATA Command Description

Command Name	Code (Hex)
NOP	00h
DATA SET MANAGEMENT	06h
RECALIBRATE	10h~1Fh
READ SECTOR(S) (w/ retry)	20h
READ SECTOR(S) (wo/ retry)	21h
READ SECTOR(S) EXT	24h
READ DMA EXT	25h
READ NATIVE MAX ADDRESS EXT	27h
READ MULTIPLE EXT	29h
READ LOG EXT	2Fh
WRITE SECTOR(S) (w/ retry)	30h
WRITE SECTOR(S) (wo/ retry)	31h
WRITE SECTOR(S) EXT	34h
WRITE DMA EXT	35h
SET MAX ADDRESS EXT	37h
WRITE MULTIPLE EXT	39h
WRITE DMA FUA EXT	3Dh
WRITE LOG EXT	3Fh
READ VERIFY SECTOR(S) (w/ retry)	40h
READ VERIFY SECTOR(S) (wo/ retry)	41h
READ VERIFY SECTOR(S) EXT	42h
WRITE UNCORRECTABLE EXT	45h
READ LOG DMA EXT	47h
WRITE LOG EXT DMA	57h
READ FPDMA QUEUED	60h
WRITE FPDMA QUEUED	61h
SEEK	70h
COMMAND DISPATCHER	80h
EXECUTE DEVICE DIAGNOSTIC	90h
DOWNLOAD MICROCODE	92h
DOWNLOAD MICROCODE DMA	93h
STANBY IMMEDIATE	94h
IDLE IMMEDIATE	95h
STANBY	96h
IDLE	97h
CHECK POWER MODE	98h
SLEEP	99h

Command Name	Code (Hex)
SMART	B0h
DEVICE CONFIGURATION RESTORE	B1h/C0h
DEVICE CONFIGURATION FREEZE LOCK	B1h/C1h
DEVICE CONFIGURATION IDENTIFY	B1h/C2h
DEVICE CONFIGURATION SET	B1h/C3h
DEVICE CONFIGURATION IDENTIFY DMA	B1h/C4h
DEVICE CONFIGURATION SET DMA	B1h/C5h
SANITIZE STATUS EXT	B4h/00h
CRYPTO SCRAMBLE EXT	B4h/11h
BLOCK ERASE EXT	B4h/12h
SANITIZE FREEZE LOCK EXT	B4h/20h
READ MULTIPLE	C4h
WRITE MULTIPLE	C5h
SET MULTIPLE MODE	C6h
READ DMA (w/ retry)	C8h
READ DMA (wo/ retry)	C9h
WRITE DMA (w/ retry)	CAh
WRITE DMA (wo/ retry)	CBh
WRITE MULTIPLE FUA EXT	CEh
STANDBY IMMEDIATE	E0h
IDLE IMMEDIATE	E1h
STANDBY	E2h
IDLE	E3h
READ BUFFER	E4h
SLEEP	E6h
FLUSH CACHE	E7h
WRITE BUFFER	E8h
READ BUFFER DMA	E9h
FLUSH CACHE EXT	EAh
WRITE BUFFER DMA	EBh
IDENTIFY DEVICE	ECh
SET FEATURES	EFh
SECURITY SET PASSWORD	F1h
SECURITY UNLOCK	F2h
SECURITY ERASE PREPARE	F3h
SECURITY ERASE UNIT	F4h
SECURITY FREEZE LOCK	F5h
SECURITY DISABLE PASSWORD	F6h
READ NATIVE MAX ADDRESS	F8h
SET MAX	F9h

4.3 Security

- The user / master password shall be concatenated with large digits of unique number like serial number to be stored in system area of Flash.
- A password setting and unlocking shall be performed less than 1sec.
- When the device receives a normal SECURITY ERASE UNIT command, the device shall erase all data blocks including unallocated (hidden) blocks through its controller of firmware.
- A firmware download can be performed regardless of the security state.

4.4 SMART Support

SK hynix SSD supports the S.M.A.R.T(Self-Monitoring, Analysis, and Reporting Technology) Command.

4.4.1 SMART Command Set

Feature field values	Command
D0h	SMART READ DATA
D1h	SMART READ ATTRIBUTE THRESHOLDS
D2h	SMART ENABLE/DISABLE ATTRIBUTE AUTOSAVE
D3h	SAVE ATTRIVUTE VALUES
D4h	SMART EXECUTE OFF-LINE IMMEDIATE
00h*	Execute SMART Off-Line routine
01h*	Execute SMART Short Self-test routine (Off-Line)
02h*	Execute SMART Extended Self-test routine (Off-Line)
04h*	Execute SMART Selective Self-test routine (Off-Line)
7Fh*	Abort Off-Line routine
81h*	Execute SMART Short Self-test routine (Captive)
82h*	Execute SMART Extended Self-test routine (Captive)
84h*	Execute SMART Selective Self-test routine (Captive)
D5h	SMART READ LOG
D6h	SMART WRITE LOG
D8h	SMART ENABLE OPERATIONS
D9h	SMART DISABLE OPERATIONS
DAh	SMART RETURN STATUS
DBh	SMART Enable/Disable Automatic Off-Line
* LBA Low Values	

4.4.2 SMART Attributes

ID	Attribute (ID)	Description
1	Raw Read Error Rate	Frequency of errors while reading raw data from disk
5	Retired Block	The number of sectors that have been reallocated, not including any pending sectors
9	Power on Hours	The number of power on hours from the time the SSD leaves the factory
12	Power Cycle Count	The number of power-on initialization takes place
100	Total Erase Count	The number of user area block erasures
168	Min. Erase Cycle Count	The number of min. erase/program cycles among blocks
169	Max. Erase Cycle Count	The number of max. erase/program cycles among blocks
171	Program Fail Count	The number of NAND program fails
172	Erase Fail Count	The number of NAND erase fails
174	Unexpected Power Loss Count	The number of unexpected power loss events
175	Program Fail Count (Worst Case Component)	The number of error events on program
176	Erase Fail Count (Worst Case Component)	The number of error Events on Erase
177	Wear Leveling Count	The number of erase/program cycles per block on average for indicate imminent wear-out
178	Used Reserved Block Count (Chip)	The number of reserved blocks used to replace bad blocks for the worst die
179	Used Reserved Block Count (Total)	The number of reserved blocks used to replace bad blocks.
180	Unused Reserved Block Count (Total)	The number of the reserved blocks remaining for the entire drive.
184	End to End Error Detection Count	The number of times that an internal data path protection error is detected
187	Reported Uncorrectable (UCC) Errors	The number of uncorrectable errors reported at the interface
188	Command Timeout Count	The number of command time outs as defined by an active command being interrupted
194	Temperature (Celsius)	Current temperature of the base casting
195	On-the-fly ECC Uncorrectable Error Rate	The number of ECC on-the-fly errors
196	Reallocation Event Count	The number of reallocation events that have taken place on the SSD, regardless of the number of sectors reallocated
198	Offline Scan Uncorrectable Sector Count	The number of uncorrected errors
199	CRC Error Count	The number of CRC errors that have occurred on the SATA interface
204	Soft ECC Correction Rate	Soft ECC rate for the current power/reset period
212	Phy Error Count	The number of Phy error
233	Normalized Media Wear-out	The number of average erase/program cycles to indicate of imminent wear-out (Counting down from 100 to 1)
234	NAND GB Written	The number of programmed pages
241	Lifetime Writes From The Host In GB	Quantity of data written to the SDD over its' lifetime (in GB count)
242	Lifetime Reads From The Host In GB	Quantity of data read from the SDD over its' lifetime (in GB count)

5.0 Certifications

Category	Certification
BSMI	Bureau of Standard, Metrology & Inspection
CE	Communaute Europeenne
FCC	Federal Communications Commission
KCC	Korea Communications Commission
RCM	Regulatory Compliance Mark
VCCI	Voluntary Control Council for Interference
TUV	Technischen Uberwachungs Vereine
CB	Scheme of the IECEE for Mutual Recognition of Test Certificates for Electrical Equipment
UL	Underwriters Laboratories Inc.
SATA-IO	Serial ATA International Organization.
Microsoft WHCK	Microsoft Windows Hardware Certification Kit
RoHS Compliant	Restriction of Hazardous Substance Directive