

GENERAL INSTALLATION MANUAL

PREMIUM SOFT ROLL-UP TONNEAU COVER



Limited Lifetime Warranty

✓ Tonno Pro offers a limited lifetime warranty against defective materials or workmanship on all Aluminum rails, aluminum components, clamps, hinges, bows and hardware. 10 Year vinyl – Tonno Pro uses the highest quality 24oz vinyl in the industry. We offer a Full 10 year warranty against defective materials or workmanship on the vinyl cover.

Warranty Conditions

✓ This warranty is against defective materials or workmanship. This warranty is void if the product has been damaged by accident, unreasonable use, neglect, improper service or installation. Any modification, acts of God, normal wear and tear or other causes not arising from defective materials or workmanship is not considered under this warranty.

Examples of conditions that void our warranty:

- Wind Whip Damage – The cover must be secure to truck when vehicle is in motion.
- Improper Cleaning – The use of cleaning chemicals not approved for cleaning vinyl. Do not use product such as Armor All. These are Vinyl Conditioners and will cause the vinyl to shrink.
- Overloading of Cargo – Cargo must not be allowed to touch the cover in any position. Protrusions in the vinyl will cause stress in the fabric and cause unnecessary weak spot in the material.

Execution and Performance

✓ Tonno Pro reserves the right to determine if all warranty conditions have been met. Upon determination Tonno Pro may require the product to be returned postage prepaid to further inspect the warranty claim. Given that all conditions are met Tonno Pro will either repair or replace (at Tonno Pro's determination) the product or the component. In the event a product must be returned, our Return Authorization # must be obtained through our customer service and must be on the returned parcel for it to be accepted. This warranty gives you specific legal rights and you may also have other legal rights which vary from state to state.

COMPLETE SIDE RAIL AND COVER INSTALLATION

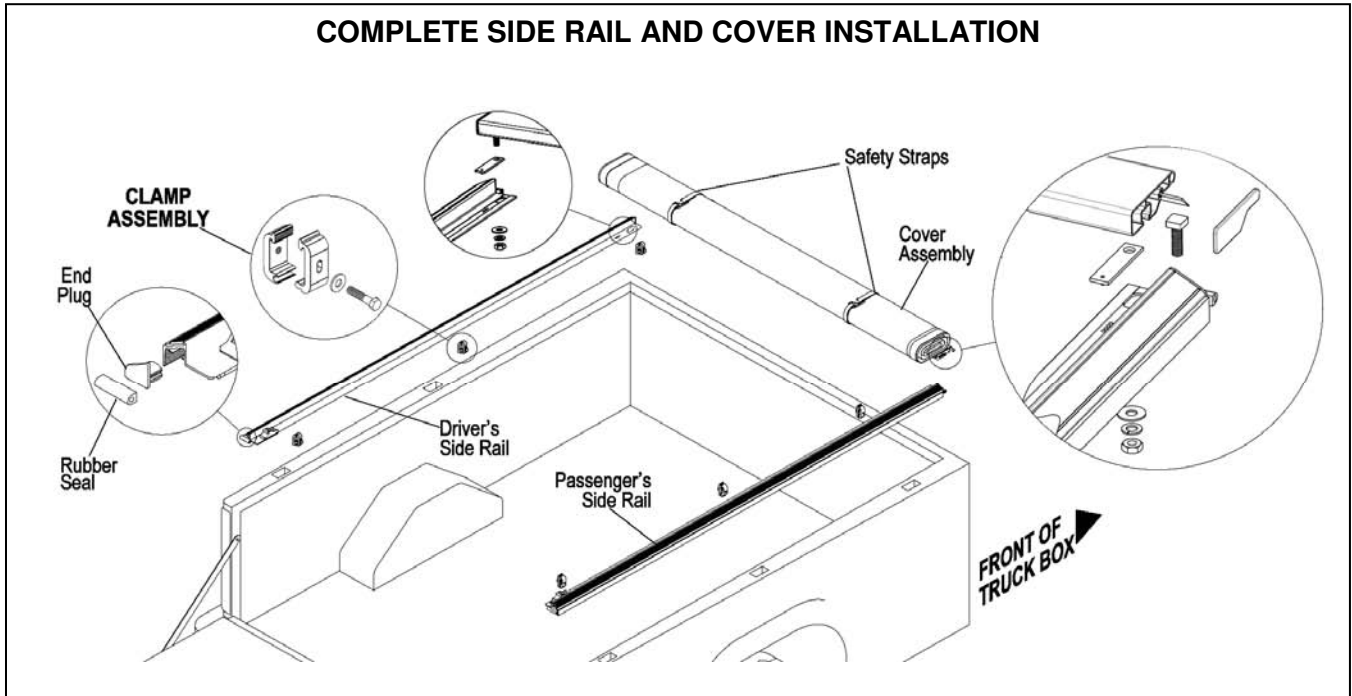

STEP 1 – Installation of Side Rails

Place the front of the side rail and round gasket tight against the front of the truck box. Starting at the tailgate evenly space the 3 clamps along each side rail leaving **approximately 6 to 8 inches** on each end.

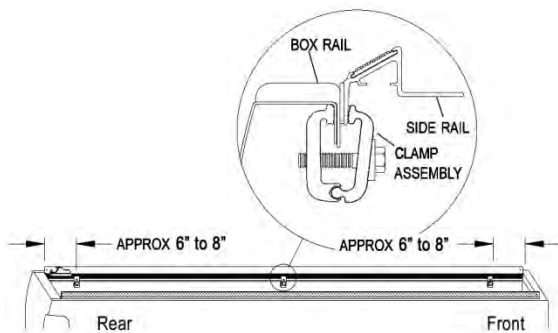

STEP 2 – Clamping & Positioning of Side Rails to Vehicle

To insure optimum performance and cover fit, the side rails must be level. To adjust the rails, loosen the screws and reposition the clamp higher or lower on the truck bed rail lip. Make sure to tighten all clamps!

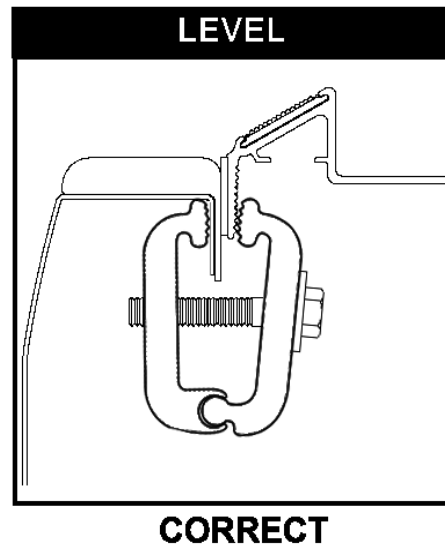

STEP 3 – INSTALLING THE COVER ASSEMBLY

Place the tension control plate on the top of the side rail and place the pin the first hole. This is the factory setting and will locate the T-Bolt in the front of the slotted hole in the side rail. (Fig. A) Next, set the cover assembly behind the cab and feed the T-Bolt down through the tension plate and side rail. The header seal should be on the top of the bulkhead of the truck. (See Fig. B) **Use supplied flat, lock washer and nut and tighten front bulkhead assembly.**

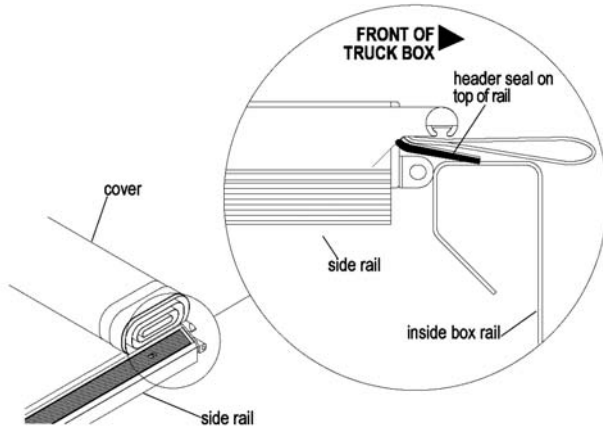

STEP 4 – LATCHING AND UNLATCHING YOUR COVER

With your tailgate open, unroll cover toward tailgate and rest bows on side rails. Rotate the tailgate header into the plastic header stops and press down to engage the catch into the latching mechanism located on the underside of the passenger side rail in the rear. Finally, Secure the hook and loop fastener strips on the side rails by pulling out the slack and then pressing along the length of the rail.

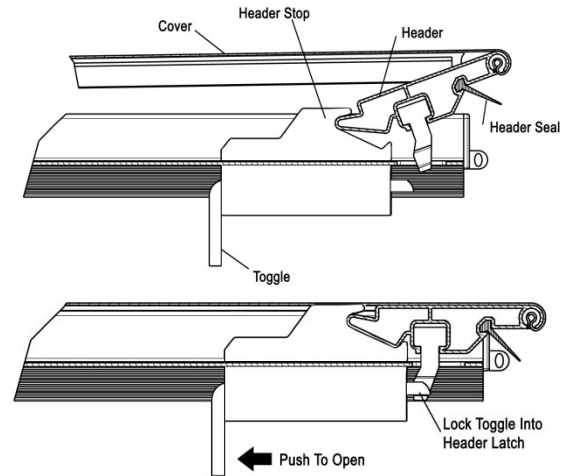

STEP 5- SECURE HOOK & LOOP FASTENER

Secure the hook and loop fastener strips on one side of the rail by pressing along the length of the rail. On the opposite side, pull the cover across the pickup bed and secure the Velcro fastener.

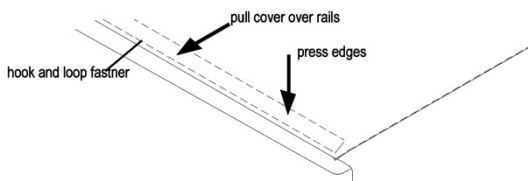

STEP 6 –RELEASE LATCH AND OPEN THE COVER

To release the cover, push the lever on the latch towards the cab of the truck to release the catch mechanism. Start to roll the cover toward the cab making sure both sides of cover roll evenly. Secure the cover open by hooking the safety straps to the front loops.

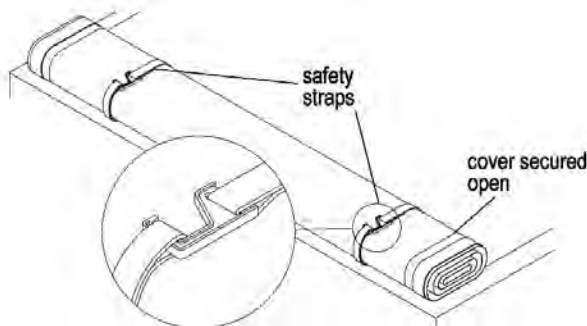

STEP 7 – TENSION CONTROL SYSTEM

Your Tonno Pro Low Roll cover has been set at the factory for moderate tension to keep your cover free of wrinkles. Dependent on weather conditions it may be necessary for you to adjust the tension control on your cover. To adjust your tension control, simply loosen the fasteners on the front bulkhead and lift up the bulkhead. Once the bulkhead is loose, simply slide the tension control plate towards the cab of the truck. **ONLY MOVE UP ONE ADJUSTMENT HOLE AT A TIME AND ALWAYS MAKE YOUR ADJUSTMENTS DURING THE WARMEST TIME OF THE DAY!** Each hole location will give you 3/16" of tension adjustment.

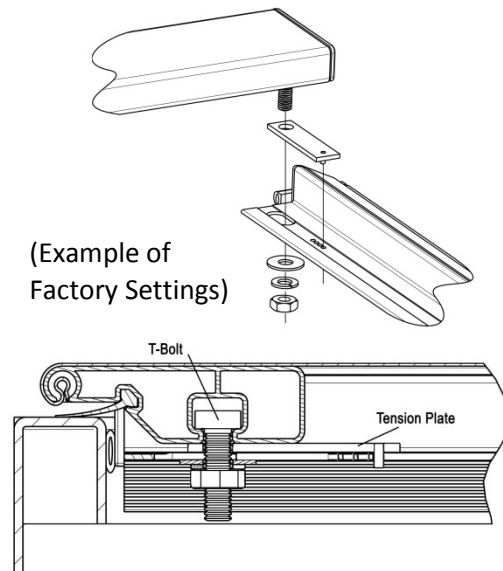

- | | | |
|---|--|----------------------------|
| 1. 001-Replacement Cover | 2. 002-Tailgate Extrusion | 3. 003-Round Bow |
| 4. 004-End Plug for Bow | 5. 005-Std. C-clamp | 6. 006-T/G Slot Mount |
| 7. 007-T/G End Cap | 8. 008-Bulkhead Extrusion | 9. 009-Tension Plate |
| 10A. 100-Side Rail End Cap (Front Pass) | 10B. 101-Side Rail End Cap (Dr. Front) | 11. 011-Flat Washer |
| 12. 012-Lock Washer | 13. 013-Nut | 14. 014-Pass-Side Rail |
| 15. 015-Driver Side Rail | 16. 016-Roll Up Strap | 17. 017-Bulkhead End Cap |
| 18. 018-T-Bolt | 19. 019-Header Block | 20. 020-Rear Catch |
| 21. 021-Rear Latch | 22. 022-Roll Up Loop | 23. 023-Rear Tension Strap |

TONNO PRO LOW ROLL REPLACEMENT PARTS

