

INSTALLATION INSTRUCTIONS

57-1534
Dodge
 2000-05 Neon
 L4-2.0L

NOTE: This kit was not designed to fit vehicles with a body lift.

TOOLS NEEDED:

- Ratchet
- Extension
- 8mm Socket
- 10mm Socket
- Flat Blade Screwdriver
- 10mm Wrench
- 13mm Wrench

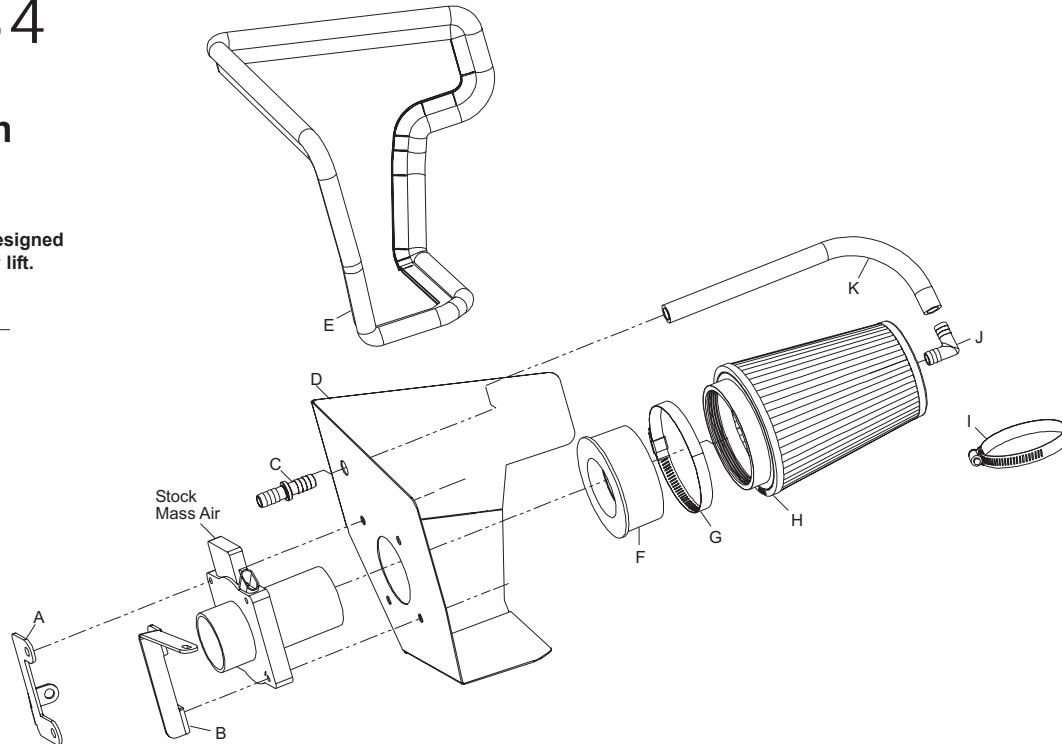

PARTS LIST:

Desc.	QTY.	Part #
A throttle body bracket	1	070063
B throttle body bracket	1	070062
C hose mender, 1/2"-1/2" barb	1	08686
D heat shield	1	074029
E edge trim 50"L	1	102481
F radiused filter adapter	1	088005
G hose clamp #64	1	08648
H filter charger	1	RU-5141
I hose clamp #48	1	08601
J hose mender, 1/2"x1/2" 90°	1	08065
K hose, 1/2" id x 14"L silicone	1	08402

NOTE: FAILURE TO FOLLOW INSTALLATION INSTRUCTIONS AND NOT USING THE PROVIDED HARDWARE MAY DAMAGE THE INTAKE TUBE, THROTTLE BODY AND ENGINE.

TO START:

1. Turn the ignition OFF and disconnect the vehicle's negative battery cable.



2. Loosen the five air box lid retaining bolts then remove air box lid as shown.



3. Remove air filter from air box assembly.



4. Disconnect the air temperature electrical connection as shown.



4a. Pull up to remove fresh air intake from the inner fender.



4b. Remove the clamp, which secures the air temperature sensor to the fresh air intake, and then remove the air temperature sensor as shown.

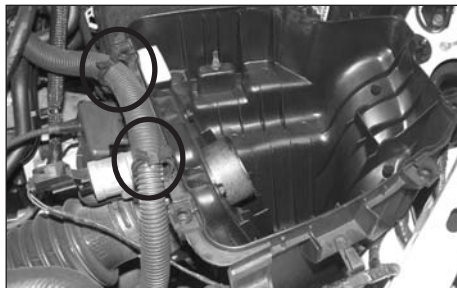

5. Unhook wiring loom from retaining clips from air box as shown.

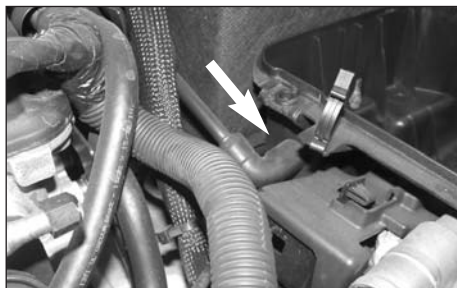

6. Remove crank case vent hose from air box.



7. Remove the four throttle body to air box retaining bolts as shown.

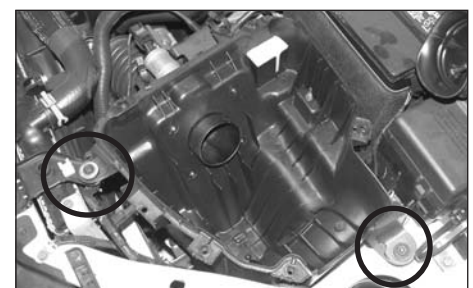

8. Remove the bolt and nut that secure the air box to vehicle.



9. Remove the air box from vehicle.



10. Remove battery tray mounting bolt.



11. Install the throttle body bracket (070063) onto the battery tray with the bolt removed in step #10.

NOTE: Do not completely tighten at this time.



12. Install the throttle body bracket (070062) onto the air box mounting bracket with the bolt removed in step #8.

NOTE: Do not completely tighten at this time.



13. Install the provided edge trim onto the heat shield as shown.



14. Install the heat shield onto the throttle body using the factory air box mounting bolts removed in step #7.

NOTE: The bolts should pass through the heat shield and throttle body brackets and thread into the throttle body.



15. Install hose mender into crankcase vent hose.

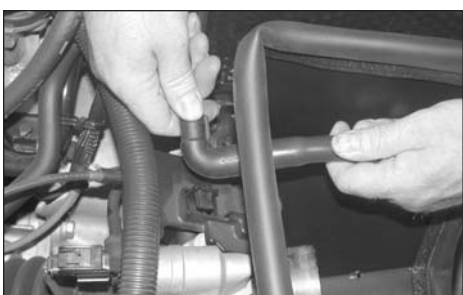

16. Pass the hose mender through the hole in the heat shield, and then install the provided silicone vent hose onto the hose mender.



17. Use provided hose clamp to secure fresh air intake to lower fresh air intake as shown.



18. Install the provided 90° vacuum fitting into the K&N filtercharger as shown.

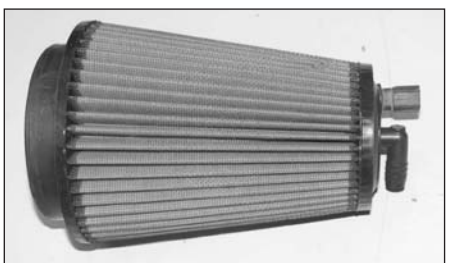

18a. Install the air temperature sensor removed in step #4b into the K&N filtercharger as shown.



19. Install the radiused filter adapter onto the throttle body as shown.



20. Install the K&N filter charger onto the radiused filter adapter and then install the provided vent hose onto the 90° fitting installed into the top of the K&N filtercharger. Reconnect the air temperature sensor electrical connection.

NOTE: Some trimming of the vent hose may be necessary.

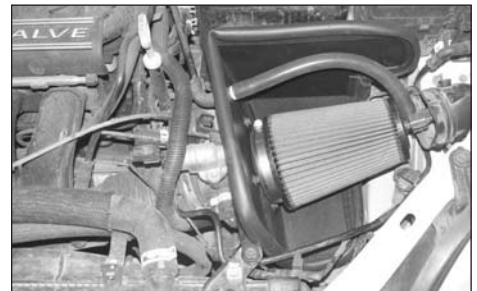

21. Reconnect the vehicle's negative battery cable. Double check to make sure everything is tight and properly positioned before starting the vehicle.

22. The C.A.R.B. exemption sticker, (attached), must be visible under the hood so that an emissions inspector can see it when the vehicle is required to be tested for emissions. California requires testing every two years, other states may vary.

23. It will be necessary for all FIPK's to be checked periodically for realignment, clearance and tightening of all connections. Failure to follow the above instructions or proper maintenance may void warranty.

ROAD TESTING:

1. Start the engine with the transmission in neutral or park, and the parking brake engaged. Listen for air leaks or odd noises. For air leaks secure hoses and connections. For odd noises, find cause and repair before proceeding. This kit will function identically to the factory system except for being louder and much more responsive.

2. Test drive the vehicle. Listen for odd noises or rattles and fix as necessary.

3. If road test is fine, you can now enjoy the added power and performance from your kit.

4. K&N suggests checking the Filtercharger element periodically for excessive dirt build-up. When the element becomes covered in dirt (or once a year), service it according to the instructions on the Recharger service kit, part number 99-5050 or 99-5000.