

# HOBART®

HOBART BROTHERS CO.  
TROY, OHIO USA

**5/3/1**  
INDUSTRIAL  
WARRANTY

# AirForce® 40i

## 240V Portable Air Plasma Cutter



272165  
Oct. 2015



**Includes:**

- 12-ft. (3.7 m) XT40R hand-held torch
- 12-ft. (3.7 m) work cable with clamp
- Extra consumables
- 10-ft. (3 m) power cord with plug
- Easy-to-connect, built-in gas/air filter and regulator for extra protection

#500566

**N**eed to cut steel? Thinking about an oxy acetylene cutting torch to do the job? Consider a plasma cutter. This simple technology uses an electrical arc and compressed air to cut steel, aluminum, and other conductive metals.

The AirForce 40i plasma cutter features an inverter design that is both lightweight and powerful. The product also features an ergonomic trigger safety, more efficient air consumption, and economically priced XT40R torch consumables. The 40i requires 240 V, 50 A input power and compressed air delivery of at least 4.8 scfm @ 90–120 psi. Maximum cutting of mild steel is 7/8 inch at 50% duty cycle for heavy-duty production requirements.

Compared to the complexities of an oxy fuel cutting torch system, plasma cutting is easy:

- Cuts faster than oxy fuel
- More precise cut, thinner kerf, less slag to clean up
- Smaller heat-affected zone for less warping
- No gas pressure settings or flame tuning needed
- No preheating of metal prior to cutting

**Applications:**

- Maintenance
- Prototyping
- Light Construction
- Body Shops/Fabrication

Features	Benefits
<b>XT40R torch</b>	Designed for increased comfort with an ergonomic trigger safety, more efficient cooling and economical replacement cutting tips.
<b>Pilot arc controller</b>	Allows you to cut expanded/perforated metals, as well as painted or coated surfaces, without retriggering the torch.
<b>Wind Tunnel Technology™</b>	Prevents abrasive dust and particles from damaging internal components.
<b>Fan-On-Demand™</b>	Cooling system operates only when needed reducing power consumption and contaminants drawn into the machine.
<b>Power factor correction (PFC) circuitry</b>	Draws up to 30% less amperage for the same cutting range as compared to the competition. PFC expands operators work area via extension cord, while minimizing nuisance circuit breaker trips caused by voltage drops.
<b>LVC™ line voltage compensation</b>	Provides peak performance power under variable input voltage conditions (±15%) for steady and cleaner-ending cuts.
<b>Internal gas/air filter and regulator</b>	Controls amount of usage and flow of air or gas.
<b>Starts without high frequency</b>	Protects unit by not interfering with or damaging controls or computers.
<b>Diagnostic lights</b>	LED lights for quick troubleshooting of pressure, power and cup situations.
<b>Cable management strap</b>	Secures torch, work cable and power cord to make transporting easy and convenient.
<b>Postflow cooling circuit</b>	Extends life of consumables and torch by cooling them with postflow air after trigger is released.
<b>Compatible with engine-driven welders</b>	Capable of cutting 3/8–5/8 in. mild steel when powered by an engine-driven welder with a 240 V generator power outlet of 8 kW or more.
<b>Hobart's 5/3/1 Industrial Warranty</b>	Five-year warranty on transformers, stabilizers and generators; three years on electronics (drive motors, rectifiers); and one year on guns (MIG and plasma torches).

**Specifications** (SUBJECT TO CHANGE WITHOUT NOTICE.)



Rated Output	Amps Input at Rated Output, 50/60 Hz, 1-Phase				Max. Open-Circuit Voltage	Plasma Gas Flow/Pressure	Dimensions	Net Weight w/Torch
	208 V	230 V	KVA	KW				
40 A with 140 VDC, 50% Duty Cycle	33	30	6.8	6.6	400 VDC	4.8 CFM (136 L/min) at 90–120 PSI (621–827 kPa) recommended	H: 11-1/4 in. (286 mm) W: 8-1/4 in. (210 mm) D: 14-1/4 in. (362 mm)	30.6 lb. (13.9 kg)

## Mild Steel Cutting Capability (THICKNESS TO SCALE.)

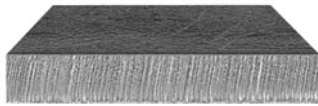

**1/4 in. (6.4 mm) at 52 IPM**

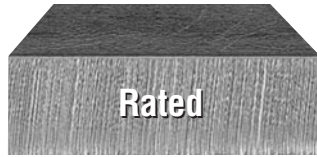

**5/8 in. (15.9 mm) at 9 IPM**

Note: Recommended maximum piercing capacity for hand-held applications is 3/16 in. (4.8 mm).

Maximum sever cut of 7/8 in. (22 mm).

For aluminum and other metals with high thermal conductivity, cutting capabilities will be derated as much as 30%.

To determine the maximum rated cutting thickness of mild steel, follow the line from the 10 IPM (inches per minute) point on the cutting chart. The point at which this line intersects the cutting curve determines the maximum recommended production cutting thickness of the unit.

Note: The rating is based on 10 IPM because this is the minimum speed at which the operator achieves a smooth, steady cut when using a hand-held torch.

### Maximum Cutting Speeds at 40 Amps Output

Thickness	Approximate Travel Speeds*
1/8 in. (3.2 mm)	130 IPM (3292 mm/min)
1/4 in. (6.4 mm)	52 IPM (1321 mm/min)
3/8 in. (9.5 mm)	28 IPM (711 mm/min)
1/2 in. (12.7 mm)	14 IPM (345 mm/min)
5/8 in. (15.9 mm)	9 IPM (224 mm/min)
3/4 in. (19.1 mm)	6 IPM (163 mm/min)

\* Travel speeds are approximately 80% of maximum.

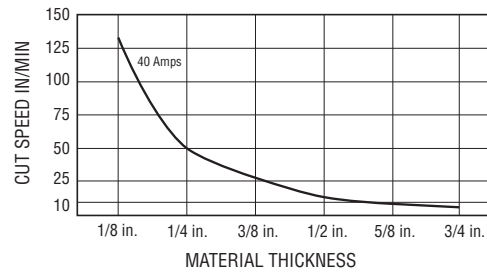

## Accessories



**XT40R Replacement Torch #268923**  
12 ft. (3.7 m)



**Protective Cover #770771**  
Weather-resistant nylon resists stains and mildew while protecting the finish of your plasma cutter.

The following accessories are available through Miller/Hobart Service Distributors.



**In-Line Air Filter Kit #228926**  
Mounts to the back of the AirForce® 12ci, 27i and 40i. Includes male and female 1/4-inch NPT quick disconnect fittings and hose for easy on/off connection. The replaceable filter element filters to .85 microns.

**In-Line Air Filter Replacement Element #228928**

Includes 1 replacement filter for in-line filter #228926.

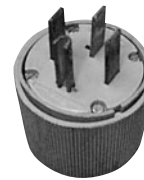

**Full KVA Plug Kit #119172**

240 VAC, 50 amp plug (NEMA 14-50P) to fit full KVA receptacle with a minimum of 8 KVA generator power.

## Torch Consumables (ORDER FROM HOBART SERVICE PARTS.)

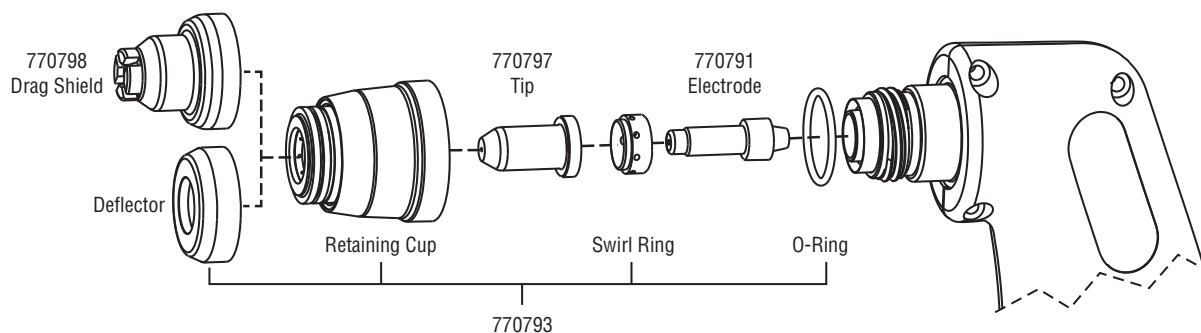

**Hobart Brothers Company** An Illinois Tool Works Company

Troy, Ohio USA Service 800-332-3281 Sales 800-626-9420

hobartwelders.com

