

CGU366SEH

GE Café™ Series 36" Gas Rangetop with 6 Burners (Natural Gas)

DIMENSIONS AND INSTALLATION INFORMATION

Professional rangetops offer a number of choices in size and rangetop configurations.

PRODUCT DIMENSIONS AND CLEARANCE:

A 36"- or 42"-wide professional vent hood with a minimum 480 CFM is recommended for installation over this rangetop.

Clearances between rangetop and side wall or combustible material must be at least 12" on each side.

Allow 8" free space below the top surface of countertop. Allow additional clearances below the burner box to install the regulator and make house gas supply connections. Use a 90° elbow to route the gas connections and limit interference with drawers or other cabinetry.

* The opening between a 4" high backsplash must be 36" to allow the rangetop to slide back against the wall.

WARNING: Installations without a hood require 48" minimum to combustibles above the rangetop. A custom hood installation with exposed horizontal combustible surfaces must have an "auto-on" feature. Refer to hood installation instructions for specific hood clearances. The surface of the entire back wall above the countertop and below the hood must be covered with a non-combustible material such as metal, ceramic tile, brick, marble or other stone.

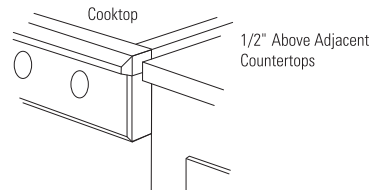
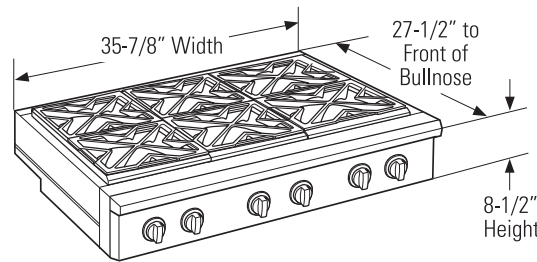

Control panel projects forward from standard-depth cabinets.

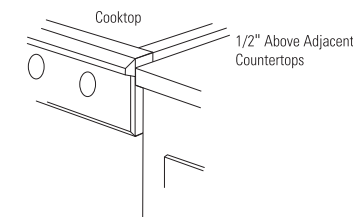

Front of deep cabinets can align with control panel beveled edge.

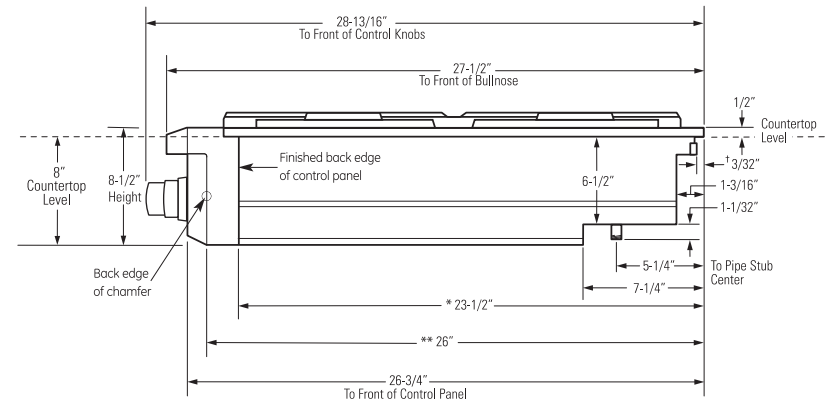
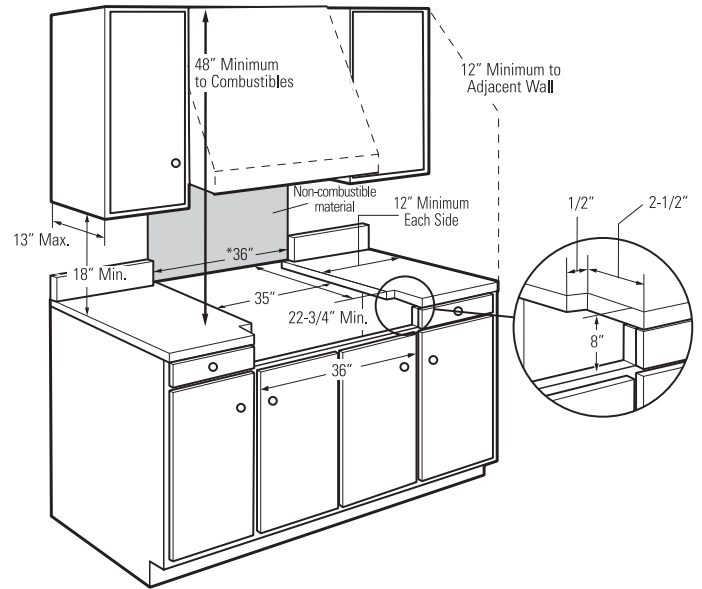

¹ Include the overhang of the rear trim when countertop continues behind the product. The overhang is decorative only. The weight of the rangetop is fully supported by the side trims.

* Minimum cabinet cutout depth from the back of the rear trim to the back finished edge of the control panel - typically, the minimum cabinet depth (front to back). Maximum cabinet cutout depth is 26" minus the countertop overhang.

** Maximum countertop cutout depth from the back of the rear trim to the back edge of chamfer at the sides of the control panel - typically, the maximum countertop cutout depth (front to back). Minimum countertop cutout depth is 25-1/4".



For answers to your Monogram, GE Café™ Series, GE Profile™ Series or GE Appliances product questions, visit our website at geappliances.com or call GE Answer Center® Service, 800.626.2000.

CGU366SEH

GE Café™ Series 36" Gas Rangetop with 6 Burners (Natural Gas)

DIMENSIONS AND INSTALLATION INFORMATION

BACKSPLASH ACCESSORIES: The rangetop requires a 12" minimum clearance to a vertical combustible surface at the rear. A backsplash is required for installations with less than 12" clearance. The following backsplash accessories are available, or a custom, non-combustible backsplash can be used.

ZX12B36PSS, 12" backsplash

ZXADJB36PSS, 30"-36" adjustable-height backsplash with warming shelf

BACKSPLASH WITH WARMING SHELF: All Professional Hoods feature infrared warming lights. The 30"-36" adjustable backsplash with warming shelf is a perfect complement when installed with the tapered or straight-sided hoods.

- Restaurant-Style Professional Hoods are shipped with a 22" stainless steel backsplash and warming shelf.

ADVANCE PLANNING FOR 36" PROFESSIONAL RANGETOPS:

Professional rangetops offer a number of choices in size and rangetop configurations.

- All Professional rangetops are factory set for natural or liquid propane gas. The correct model should be ordered for the installation situation.

NOTE: Conversion kits are included with the rangetop if the wrong gas type was ordered. High Altitude kit, WB28K10553, is also available. The kits must be installed by a qualified service technician at additional cost.

Side View with a Backsplash

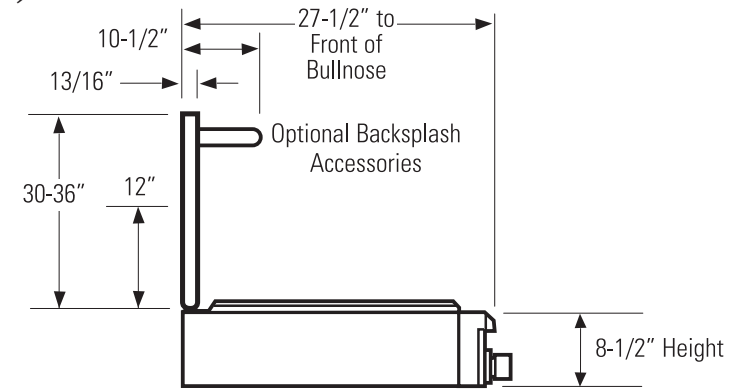

Universal Utility Locations

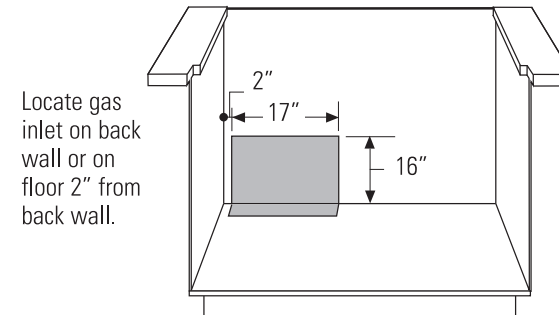

ELECTRICAL REQUIREMENTS: Rangetops must be supplied with 120V, 60Hz, and connected to an individual, properly grounded branch circuit protected by a 15 amp circuit breaker or time-delay fuse.

GAS SUPPLY:

- Natural gas models are designed to operate at 5" water column pressure. For proper operation, the pressure of the natural gas supplied to the regulator must be between 7" and 13" water column.

- The liquid propane models are designed to operate at 10" water column pressure. For proper operation, the pressure of the LP source to the regulator must be between 11" and 13" water column.



For answers to your Monogram, GE Café™ Series, GE Profile™ Series or GE Appliances product questions, visit our website at geappliances.com or call GE Answer Center® Service, 800.626.2000.

CGU366SEH

GE Café™ Series 36" Gas Rangetop with 6 Burners (Natural Gas)

FEATURES AND BENEFITS

Stainless Steel, Deep-Recessed Cooktop - Contains spills for quick and easy cleaning

6 Sealed dual flame stacked burners (18,000 BTUs) - Deliver a full spectrum of heat settings, from an ultra-low 140° F simmer to an intense 18,000 BTU

Electronic Ignition - Ensures a continuous flame and reignites automatically if accidentally extinguished

Reversible burner grates - Flat on one side and uniquely contoured on the other to accommodate round-bottom woks

Heavy-Cast, Edge-to-Edge Grates - Allow for easy movement of pans between burners

Model CGU366SEHSS - Stainless steel

