

STEP 3

Attach Panel (E) with Power Pin(5).

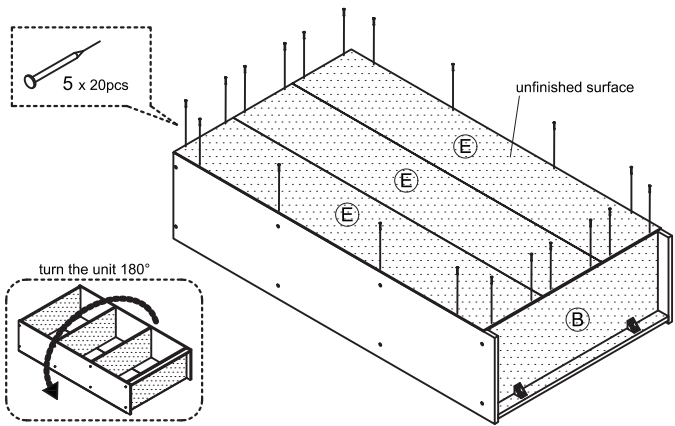

STEP 4

Install Nail Leg(3) to the bottom of Panel (D) with hammer.

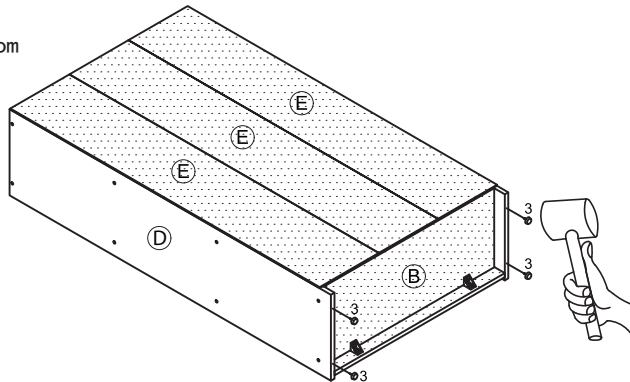

Recommended Maximum Weight

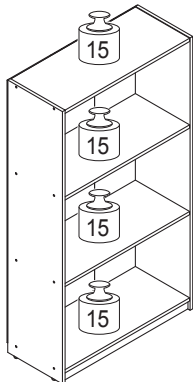

*Unit in Pound(lbs)

WARNING:

>This unit has been designed to support the maximum loads shown. Exceeding these load limits could cause sagging, instability, product collapse, and/or serious injury.

>DO NOT allow children to climb on unit.

>Put heavier items on lower shelves.



Assembly Instruction

Furinno Basic 3-Tier Bookcase
Storage Shelves

MODEL : **99736**

DIMENSION : 21.8"(W) x 39.5"(H) x 9.3"(D)

00:30

Approx. 30 minutes



Recomm. 2 Person

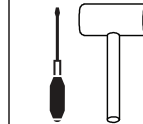

Tool Required

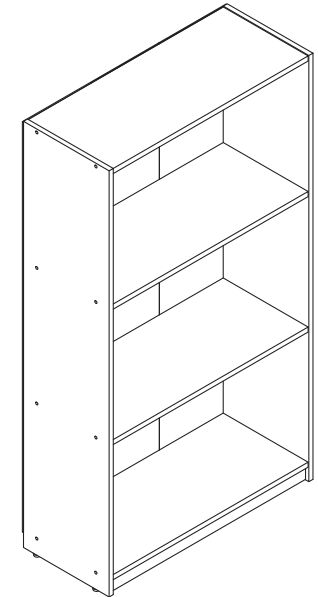

Customer Service

Tel/Fax: 281.500.9372





Toll Free: 773.299.8111 (Mon - Fri 9am - 5pm)





Email: support@furinno.com

www.furinno.com

Find us on
f Facebook

Pinterest

No	Hardware List	Qty
1	Long Screw 	16pcs
2	Short Screw 	4pcs
3	Nail Leg 	4pcs
4	L-Bracket 	2pcs
5	Power Pin 	20pcs

No	Parts List	Qty
A	Shelf Panel 	3pcs
B	Bottom Panel 	1pcs
C	Bottom Bar 	1pcs
D	L/R Side Panel 	2pcs
E	Back Panel 	3pcs

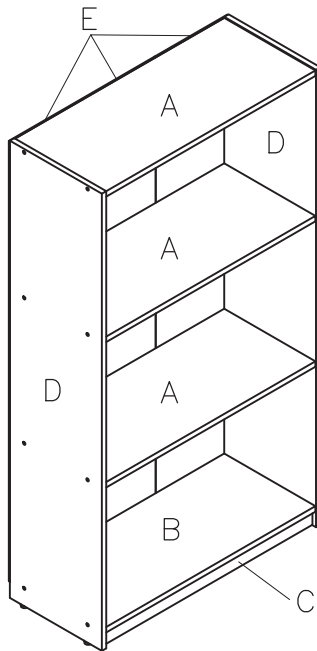

USEFUL HINTS BEFORE YOU START:

1. Read each step carefully before starting.
2. It is important that each step is performed in correct order to avoid difficulties.
3. Identify, sort and count the parts before assembly.
4. Assemble your furniture on packaging cardboard to prevent scratch or damage.
5. Clean the product with mild cleanser using soft damp cloth. Do not use harsh or abrasive cleanser.
6. Using incompatible hardware might cause damage to product.

STEP 1

- 1.1 Install L-Bracket (4) to Panel (C) with Screw (2).
- 1.2 Attach Panel (C) to Panel (B) and tighten with Screw (2).

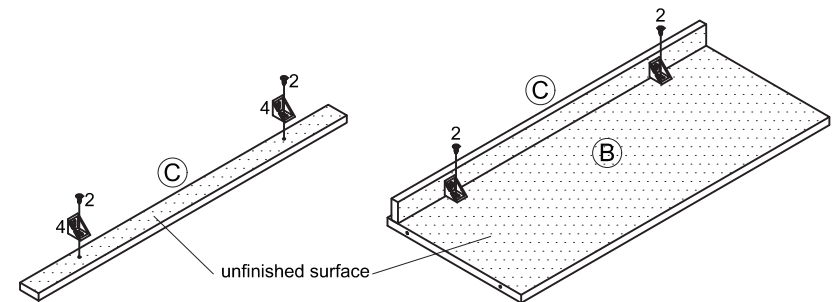

STEP 2

Attach Panel (A) & (B) to Panel (D) and tighten with Long Screw (1).

