



LaCie Rugged Thunderbolt USB-C User Manual



Click here to access an up-to-date online version of this document. You will also find the most recent content as well as expandable illustrations, easier navigation, and search capability.

Contents

1	Introduction	4
	Box content	4
	Minimum system requirements	4
	Ingress Protection rating	5
2	Cables and Connectors	6
	Thunderbolt	6
	• Thunderbolt cable	6
	• Thunderbolt and Windows	6
	USB-C	6
	• USB-C cables	7
	• USB 3.1 (USB-C) cable	7
	• USB 3.1 (USB-C)-to-USB 3.0/2.0 (Type A) cable	8
3	Getting Connected	9
	Step 1 - Remove the port cover	9
	Step 2 - Connect to your computer	9
	• Thunderbolt connection	9
	• USB-C connection	10
	• USB-C to USB 3.0/2.0 connection	10
	Step 3 - LaCie Setup Assistant	10
	• Launch LaCie Setup Assistant - Mac	11
	• Launch LaCie Setup Assistant - Windows	11
	• LaCie Setup Assistant steps	12
4	Install Drivers (Windows Only)	14
5	Optional Formatting and Partitioning	15
	About file system formats	15
	Formatting instructions	15
	• Windows	16
	• Mac	16
6	Safely Remove Rugged Thunderbolt USB-C From Your Computer	17
	Mac	17
	• Eject via Finder window	17
	• Eject via Desktop	17
	Windows	17

7	Frequently asked questions	19
	All users	19
	• Problem: My file transfers are too slow.	19
	• Problem: I have an older computer with USB 2.0 ports.	19
	• Problem: I must use a USB hub for my USB devices.	19
	• Problem: The provided USB cables are too short	20
	• Problem: I must password protect and/or encrypt my hard drive.	20
	• Problem: I'm receiving file transfer error messages.	20
	Mac	21
	• Problem: The hard drive icon does not appear on my desktop.	21
	Windows	21
	• Problem: The hard drive icon doesn't appear in Computer.	21
8	Warranty Information	23
	Legal Information	23
	LaCie Limited Warranty Policy	23
	EXCLUSIONS AND LIMITATIONS	24
	DOA	25
	Customer Warning	25

Introduction

Welcome to the user manual for LaCie Rugged Thunderbolt USB-C. You have three options for connecting LaCie Rugged Thunderbolt USB-C to your computer:

- Thunderbolt
- USB 3.1 Gen 2 (USB-C)
- USB 3.0/USB 2.0 (USB Type A)

Additionally, LaCie Rugged Thunderbolt USB-C's casing is lightweight for easy travel and it withstands bumps and drops of up to 2 meters. Professionals and enthusiasts can appreciate LaCie Rugged Thunderbolt USB-C's durability while enjoying high-end performance when connected to a computer with Thunderbolt or USB 3.1 ports.

Review this user manual for instructions how to connect LaCie Rugged Thunderbolt USB-C to your computer. For common questions and answers about your hard drive, please see [Frequently asked questions](#).

You can get the latest tips regarding your product and updated technical information at [LaCie customer support](#).

Box content

- LaCie Rugged Thunderbolt USB-C
- USB 3.1 Gen 2 (USB-C) cable
- USB 3.1 Gen 2 (USB-C)-to-USB 3.0/2.0 (Type A) cable
- Quick Install Guide
- Software: LaCie Backup Assistant



Note: A PDF of this user manual and software utilities are pre-loaded on the drive.



Important info: Save your packaging. If you experience problems with your hard drive and want to exchange it, the hard drive must be returned in its original packaging.

Minimum system requirements

You can connect your LaCie device to a computer that meets the following minimum requirements:

- Windows 7 or higher

- Mac OS X 10.7 or higher



Note: For optimal performance, connect the product to a Thunderbolt or USB 3.1 host port on your computer. Connecting LaCie Rugged Thunderbolt USB-C to a USB 2.0 connection only provides up to 480Mb/s.

Ingress Protection rating

The Ingress Protection (IP) rating is a standard for defining the types of protection supported by equipment and devices. The two-digit code for IP lets users know the conditions that the device can withstand. The two digits are independent, with each number representing a different level of protection.

LaCie Rugged Thunderbolt USB-C is rated IP 54.

- 5: Protection against dust from entering the device's internal mechanism.
- 4: Protection against splashing water from any angle.

LaCie Rugged Thunderbolt USB-C is also protected when it is dropped from heights up to 2 meters / 6.6 feet (in non-operating mode).



Important info regarding the IP rating and the port cover: LaCie Rugged Thunderbolt USB-C's IP 54 rating is valid when the cover is securely fastened on the device. You can attach the cover when using the integrated Thunderbolt cable. However, the cover cannot be attached when using the USB port.

Cables and Connectors

You can connect LaCie Rugged Thunderbolt USB-C to your computer using Thunderbolt or USB. Review the connection types below.

Thunderbolt

LaCie Rugged Thunderbolt USB-C features an integrated Thunderbolt cable that connects directly to your computer. Thunderbolt technology supports two 10Gb/s bi-directional channels from a single port. At 10Gb/s, a full-length HD movie can be transferred in less than 30 seconds.

Thunderbolt cable

For ease of access, the Thunderbolt cable is integrated on LaCie Rugged Thunderbolt USB-C. Remove the interface cover and gently unwind the Thunderbolt cable before attaching it to your computer.

Holding, dangling, or transporting Rugged Thunderbolt USB-C by its integrated cable is strongly discouraged. Doing so can invalidate the product warranty.

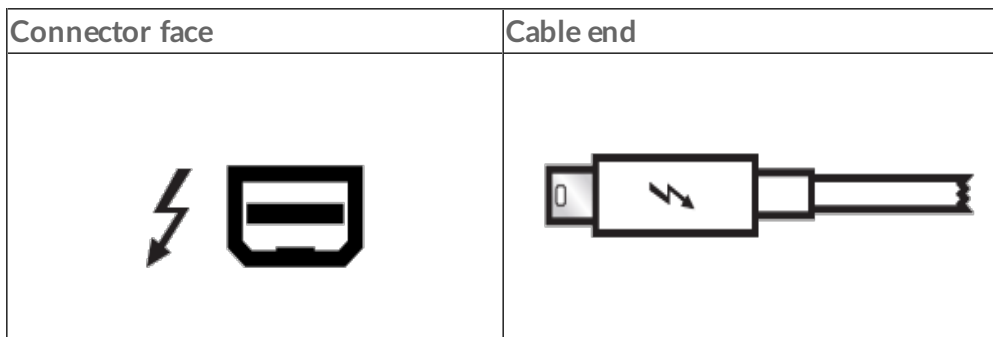

Thunderbolt and Windows

Windows users must connect the product via USB and install drivers before using the Thunderbolt cable. See [Getting Connected](#) for details.

USB-C



USB-C protocols

USB is a serial input/output technology for connecting peripheral devices to a computer. USB-C is the latest implementation of this standard and it provides higher bandwidth and new power management features.

USB-C supports many protocols:

- Thunderbolt 3: transfer rates up to 40Gb/s
- USB 3.1 Gen 2: transfer rates up to 10Gb/s
- USB 3.1 Gen 1: transfer rates up to 5Gb/s
- SuperSpeed USB 3.0: transfer rates up to 5Gb/s
- Hi-Speed USB 2.0: transfer rates up to 480Mb/s

The USB-C port on LaCie Rugged Thunderbolt USB-C is USB 3.1 Gen 2 for models shipped with SSDs. Models with hard drives are USB 3.1 Gen 1.

USB-C cables

Your LaCie hard drive is shipped with two cables for universal compatibility with all modern computers:

- USB 3.1 Gen 2 (USB-C)
- USB 3.1 Gen 2 (USB-C)-to-USB 3.0/2.0 (Type A)

For optimal transfer rates via USB, connect LaCie Rugged Thunderbolt USB-C to a USB 3.1 Gen 2 port on your computer. LaCie Rugged Thunderbolt USB-C also supports connections to computers with USB 3.0 and USB 2.0 ports.

USB 3.1 (USB-C) cable

Use the USB-C cable to ensure maximum data transfer rates with compatible ports. Connecting your product is easy since the USB-C cable is identical on both ends. Further, the USB-C ports on your LaCie hard drive and computer are conveniently rounded to accept the cable end no matter how it is connected.

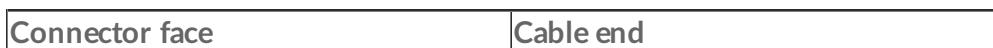

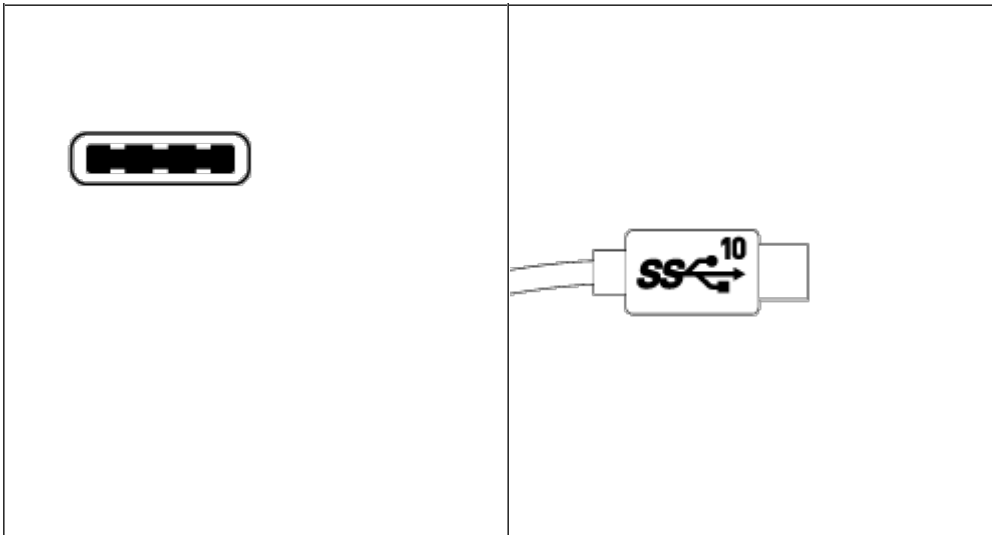





USB 3.1 (USB-C)-to-USB 3.0/2.0 (Type A) cable

Use the USB 3.1 (USB-C)-to-USB 3.0/2.0 (Type A) cable for compatibility with computers that do not have a USB-C port. The USB-C end is connected to the LaCie hard drive and the Type A end is connected to the computer's USB 3.0 or USB 2.0 Type A port.

Hard drive performance is limited to USB 3.0 transfer rates when connected to a USB 3.0 port and USB 2.0 transfer rates when connected to a USB 2.0 port

Connector face (USB Type A to computer)	Cable end (USB Type A to computer)	Cable end (USB-C to product)	Connector face (USB-C to product)
			

Getting Connected

Follow the setup steps in the order they are given to ensure that your LaCie hard drive's volume mounts correctly on your computer.

Step 1 - Remove the port cover

Remove the cover by placing your index finger on its right edge and gently prying it open.

Step 2 - Connect to your computer

Before connecting LaCie Rugged Thunderbolt USB-C, confirm the port on your computer. Your LaCie device is shipped with the following cables:

- **Thunderbolt (integrated on the device):** use this cable if your computer has a Thunderbolt or Thunderbolt 2 port.
- **USB 3.1 Gen 2 (USB-C):** use this cable if your computer has a USB-C port.
- **USB 3.1 Gen 2 (USB-C)-to-USB 3.0/2.0 (Type A):** use this cable if your computer does not have a Thunderbolt/Thunderbolt 2 port or a USB-C port.



Note: If the drive does not mount on your computer, see troubleshooting topics in the [Frequently asked questions](#) section to help resolve common issues.

Thunderbolt connection

Use the integrated cable to connect LaCie Rugged Thunderbolt USB-C to a Thunderbolt or Thunderbolt 2 port on your computer.

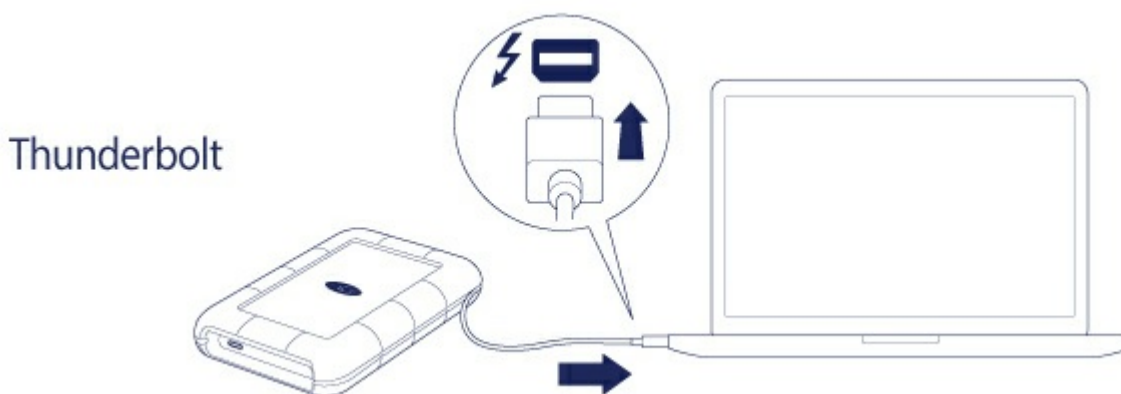

USB-C connection

Connect the cable to the USB-C port on LaCie Rugged Thunderbolt USB-C and a USB-C port on your computer.

USB-C/USB-C

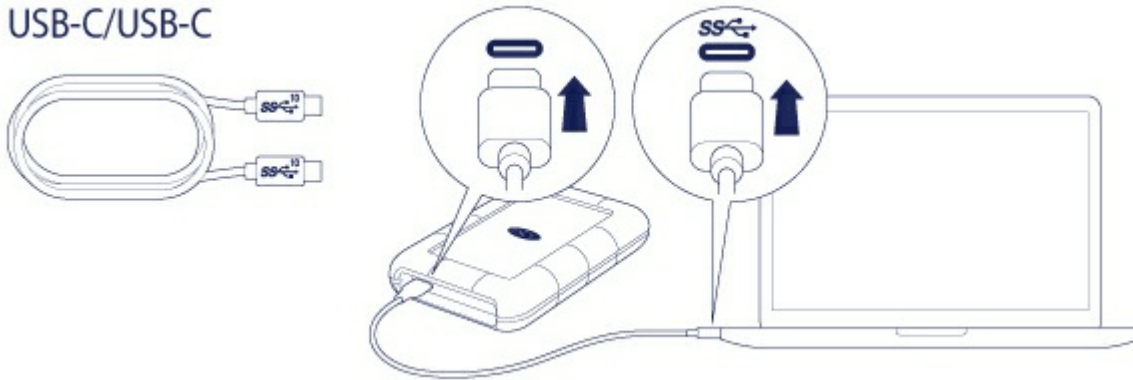

USB-C to USB 3.0/2.0 connection

Connect the cable to the USB-C port on LaCie Rugged Thunderbolt USB-C and a USB 3.0/2.0 Type A port on your computer.

USB-C/USB 3.0 & 2.0

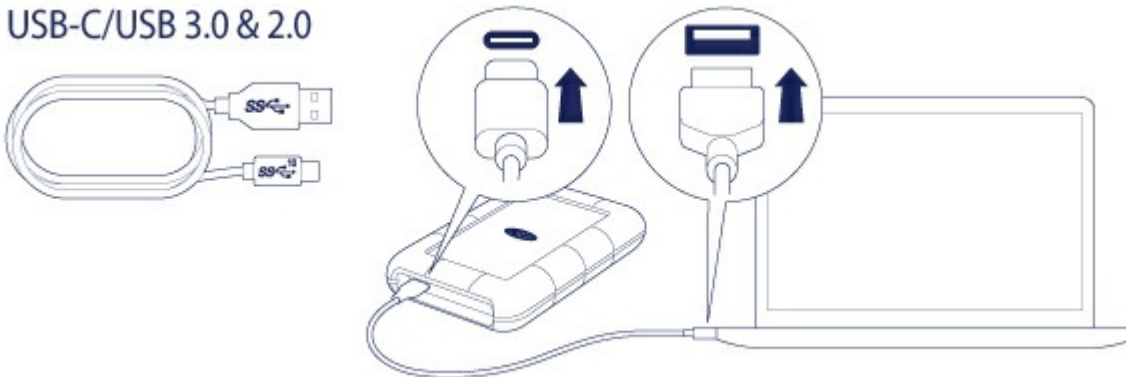

Step 3 - LaCie Setup Assistant

LaCie Setup Assistant must be launched before using your drive. It will allow you to:

- Easily format the hard drive according to your needs.
- Register your LaCie device.
- Copy the user manual to the hard drive.
- Install software for added features.

i Important info: If you do not launch LaCie Setup Assistant or if you quit LaCie Setup Assistant after the formatting has begun, your drive will not be ready to use and will require manual formatting. Additionally, the user manual and utilities will not be available and must be downloaded from [LaCie customer support](#).

Launch LaCie Setup Assistant - Mac

Open the **LACIE SETUP** volume on your desktop and then double click **LaCie Setup**.

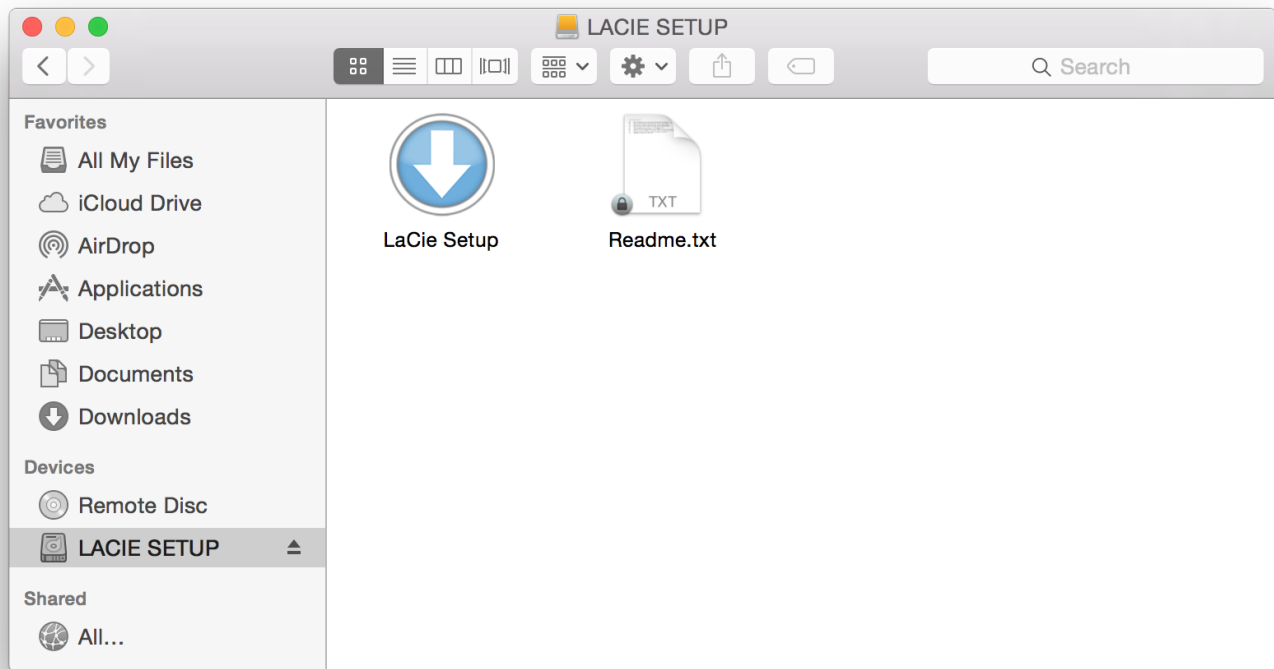

Launch LaCie Setup Assistant - Windows

AutoPlay: Windows AutoPlay may detect your LaCie hard drive as soon as it is connected to your computer. If the AutoPlay window appears, choose **Open folder** to view files using Windows Explorer and double-click **LaCie Setup**.

LaCie Setup (E:)

Choose what to do with removable drives.



Configure this drive for backup
File History



Configure storage settings
Settings



Open folder to view files
File Explorer



Take no action

Manual access: open the **LACIE SETUP** volume in a **Windows Explorer** window and double-click **LaCie Setup**.

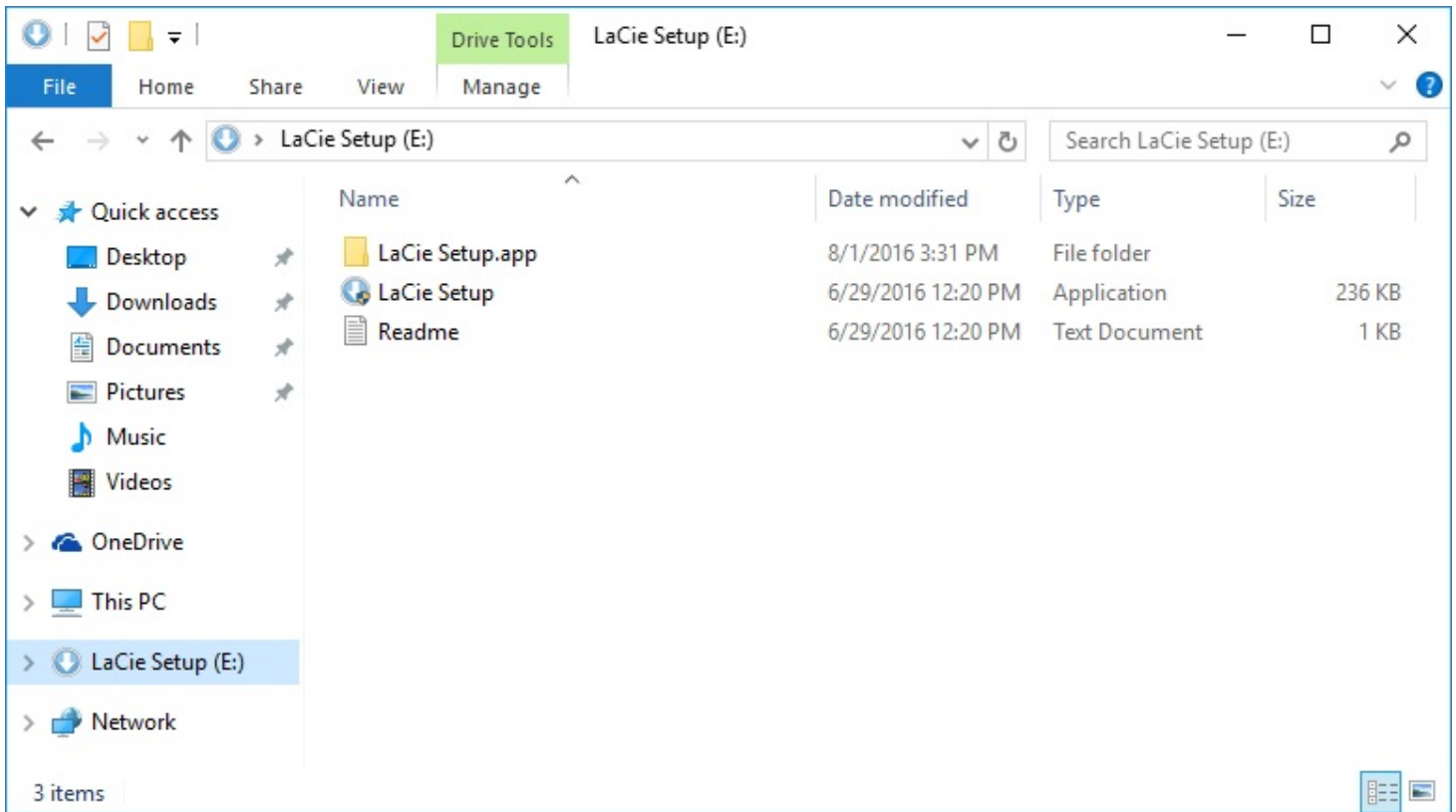

LaCie Setup Assistant steps

Follow the steps below to format your LaCie device for your operating system. LaCie Setup Assistant guides

you through formatting and registering your hard drive as well as installing LaCie software utilities.

You can also use your system's native disk utility program to format or partition your LaCie drive. If you use the disk utility, you can download software utilities and the user manual from [LaCie customer support](#).

i **Important info for Mac users:** You may be prompted to enter your computer password to continue with LaCie Setup Assistant.

i **Important info for Windows users:** While running LaCie Setup Assistant, generic pop-up windows may ask if you wish to change your computer's settings. This is a normal request when formatting a hard drive or installing software. To successfully complete LaCie Setup Assistant, please agree to change the settings.







1. Select your language.
2. Read the license agreement before choosing **Next**. Selecting **Next** confirms that you accept the license agreement.
3. Use the slider to partition your LaCie hard drive. There are two options for partitions:
 - **LaCie Share:** formatted as FAT32 for compatibility with Windows and Mac.
 - **LaCie:** formatted for your operating system, NTFS for Windows or HFS+ for Mac.Move the slider to the left to reduce the size of the **LaCie Share** partition. If you do not want the **LaCie Share** volume, move the slider all the way to the left.
4. A prompt alerts you that the disk will be formatted. Select **Yes** to continue. LaCie Setup Assistant formats the hard drive.
5. Register your LaCie device.
6. Choose the software utilities that you want to install. Certain software utilities may begin to install before LaCie Setup Assistant has finished. Follow the software utility installer before completing LaCie Setup Assistant. If you do not install software utilities during this step, you can return to LaCie Setup Assistant at any time.
7. LaCie Setup Assistant provides a summary of the installation. Choose **Finish** to close the program.

To install software utilities after the initial installation, you can run LaCie Setup Assistant again. Since the format is complete you are only prompted to choose software utilities. LaCie Setup Assistant is available on:

- **LaCie Share:** if you created two partitions
- **LaCie:** if you created one partition

Install Drivers (Windows Only)

Windows users must install drivers on their computer in order to use the Thunderbolt connection. Before following the steps below, make certain to review the steps to connect the product to a Windows PC via **USB** as described in [Getting Connected](#).

1. Click [Rugged Thunderbolt driver](#) to download the driver.
2. Unzip the downloaded file.
3. Double-click **Setup.exe**.  
4. Follow the steps to complete the wizard.  
5. When prompted, restart your computer.  
6. Connect LaCie Rugged Thunderbolt USB-C to your PC using the Thunderbolt cable (see [Getting Connected](#)).

Optional Formatting and Partitioning

You can use LaCie Setup Assistant to format your LaCie hard drive when it is first connected to a computer (Mac or Windows). LaCie Setup Assistant helps you to quickly format the storage device according to your needs.

Read the information below if you:

- Aborted LaCie Setup Assistant while it was formatting.
- Want to reformat your storage device after successfully formatting the hard drive with LaCie Setup Assistant.

About file system formats

NTFS: since it is the native file system for Windows, volumes created in NTFS are read and write with computers running Windows. Mac OS can read NTFS volumes but cannot natively write to them.

Mac OS Extended (HFS+): the native hard drive file system for Mac. Windows cannot natively read or write to HFS+ (journaled) hard drives.

exFAT: generally compatible with Mac and Windows. exFAT is not a journaled file system which means it can be more susceptible to data corruption when errors occur or the drive is not disconnected properly from the computer.

FAT32: compatible with Mac and Windows. However, FAT32 is a legacy file system designed for low capacity hard drives and it is not recommended for modern hard drives or operating systems. A FAT32 partition can reach up to 32GB when formatted on a Windows PC.

How to choose the file system format

Use NTFS if:

...the storage device is connected to Windows PCs.

Use HFS+ if:

...the storage device is connected to Macs.

You can use exFAT if:

...the storage device is shared between Mac and Windows computers.

Use FAT32 if:

...the storage device is connected to older Windows and Mac computers. FAT32 is not recommended for modern operating systems and computers.

Formatting instructions

The steps below help you format and partition a storage device.

! **Caution:** Formatting erases everything on the storage device. LaCie highly recommends that you back up all data on your storage device before performing the steps below. LaCie is not responsible for any data lost due to formatting, partitioning or using a LaCie storage device.



Note: Refer to your operating system's documentation for more information on formatting and partitioning storage devices.

Windows

1. Make sure the storage device is connected to your computer.
2. Go to Search and then type **diskmgmt.msc**. In the search results, double click **Disk Management**.
3. From the list of storage devices in the middle of the Disk Management window, locate your LaCie device.
4. The partition must be available to format. If it is currently formatted, right click on the partition and then choose **Delete**.
5. To create a new partition, right click on the volume and select **New Simple Volume**. Follow the on-screen instructions in the New Simple Volume Wizard.

Mac

1. Make sure the storage device is connected to your computer.
2. Select **Go > Utilities** in the Finder menu bar.
3. In the Utilities folder, double-click **Disk Utility**.  All connected storage devices, partitions or disk images are displayed in the left column.
4. Select the LaCie hard drive in the left column.
5. Click the **Erase** tab.
6. Choose a format from the drop-down window.
7. Enter a name for the volume.
8. Click **Erase** and confirm your selection in the pop-up window.

Safely Remove Rugged Thunderbolt USB-C From Your Computer

Always eject a storage drive from your computer before physically disconnecting it. Your computer must perform filing and housekeeping operations on the drive before it is removed. Therefore, if you unplug the drive without using the operating system's software, your files can become corrupt or damaged.

Mac

There are several ways you can eject your hard drive from a Mac. See below for two options.

Eject via Finder window

1. Open a Finder window.
2. On the sidebar, go to Devices to locate LaCie and click the eject symbol to the right of the drive name.
3. Once the hard drive disappears from the sidebar or, the Finder window closes, you can disconnect the hard drive's cable from your Mac.

Eject via Desktop

1. Select the desktop icon for your hard drive and drag it to the Trash.
2. When the hard drive's icon is no longer visible on your desktop, you can physically disconnect the hard drive from your Mac.

Windows

Use the Safely Remove tool to eject a hard drive.

1. Click the Safely Remove icon in your Windows System Tray to view the devices you can eject.

- Windows 7:

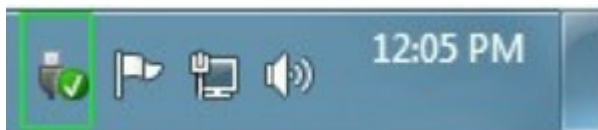

- Windows 8 / Windows 10:

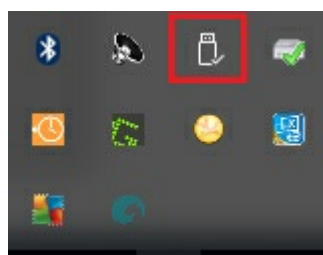

2. If you don't see the Safely Remove Hardware icon, click the **Show hidden icons arrow** in the system tray

to display all icons in the notification area.

3. In the list of devices, choose the device you want to remove. Windows displays a notification when it is safe to remove the device.
4. Disconnect the hard drive from the computer.

Frequently asked questions

For help setting up and using your LaCie hard drive, review the frequently asked questions below. For additional support resources, go to [LaCie customer support](#).

All users

Problem: My file transfers are too slow.

Q: Are both ends of the USB cable firmly attached?

A: Review troubleshooting tips for cable connections below:

- Check both ends of the Thunderbolt or USB cable and make sure that they are fully seated in their respective ports.
- Try disconnecting the cable, waiting 10 seconds, and then reconnecting it.
- Try a different cable (USB only).

Q: Is the hard drive connected to a Thunderbolt 2 port on your computer or hub?

A: While Thunderbolt 2 has the potential to reach transfers rates up to 20Gb/s, the port on LaCie Rugged Thunderbolt USB-C is Thunderbolt, which can reach up to 10Gb/s.

Q: Is the hard drive connected to a USB 2.0 port on your computer or hub?

A: If your hard drive is connected via USB to a Hi-Speed 2.0 port or hub, performance is limited to speeds up to 480Mb/s.

Q: Are there other Thunderbolt or USB devices connected to the same port or hub?

A: Disconnect other devices and see if the hard drive's performance improves.

Problem: I have an older computer with USB 2.0 ports.

Q: Will my hard drive's USB 3.1 port work with my computer's USB 2.0 port?

A: Yes, the cable end that plugs into the computer (USB Type A) is compatible with both USB 3.0 and USB 2.0. Make certain to use the included cable with the correct USB Type A connector. The transfer rates are much slower with USB 2.0.

Problem: I must use a USB hub for my USB devices.

Q: Can I use my hard drive with a USB hub?

A: Yes, the hard drive can be connected to a USB hub. If you use a hub and encounter detection problems, slower than normal transfer rates, random disconnection from your computer or other unusual issues, try connecting the hard drive directly to the computer's USB port.

Some USB hubs are less than efficient with power management, which can be problematic for connected devices. In such a case, consider trying a powered USB hub that includes a power cable.

Please note that USB 2.0 hubs limit your hard drive's transfer rates to USB 2.0 speeds.

Problem: The provided USB cables are too short.

Q: Can I use my hard drive with a longer cable?

A: Yes, provided it is certified according to USB standards. However, LaCie recommends using the cable shipped with your hard drive for the best results. If you use a longer cable and experience problems with detection, transfer rates or disconnection, use the original cable included with your hard drive.

Problem: I must password protect and/or encrypt my hard drive.

Q: Can I protect my hard drive with a password?

A: Yes, it is possible to protect the hard drive or individual folders and files with a password. There are many third-party solutions for password protection. However, LaCie cannot guarantee them since we do not test third-party applications.

Some versions of Windows have a built-in utility called Bitlocker that can protect hard drives with a password. For more information about Bitlocker, consult Microsoft's support documentation.

Q: Can I encrypt my hard drive?

A: Yes, the hard drive can be encrypted. There are many third-party solutions for encryption. However, LaCie cannot guarantee them since we do not test third-party applications.

Some versions of Windows have a built-in utility called Bitlocker that can encrypt hard drives. For more information about Bitlocker, consult Microsoft's support documentation

Problem: I'm receiving file transfer error messages.

Q: Did you get an "Error -50" message while copying to a FAT32 volume?

A: When copying files or folders from a computer to a FAT32 volume, certain characters in the names cannot be copied. These characters include, but are not limited to: ? < > / \ :

Check your files and folders to ensure that these characters are not in the names.

If this is a recurring problem or you cannot find files with incompatible characters, consider reformatting the drive to NTFS (Windows users) or HFS+ (Mac users). See [Optional Formatting and Partitioning](#).

Q: Did you get an error message telling you that the drive has been disconnected when coming out of sleep mode?

A: Ignore this message since the drive remounts on the desktop despite the pop-up. LaCie drives conserve power by spinning down when you set your computer to sleep mode. When the computer awakes from sleep mode, the drive may not have enough time to spin up, causing the pop-up to appear.

Mac

Problem: The hard drive icon does not appear on my desktop.

Q: Is your Finder configured to hide hard drives on the desktop?

A: Go to Finder and then check **Preferences > General tab > Show these items on the desktop**. Confirm that **Hard Disks** is selected.

Q: Is your hard drive mounting in the operating system?

A: Open Disk Utility at **Go > Utilities > Disk Utility**. If the hard drive is listed in the left-hand column, check your Finder preferences to see why it is not displayed on the desktop (review the question above).

Q: Does your computer's configuration meet the minimum system requirements for use with this hard drive?

A: Refer to the product packaging for the list of supported operating systems.

Q: Did you follow the correct installation steps for your operating system?

A: Review the installation steps in [Getting Connected](#).

Windows

Problem: The hard drive icon doesn't appear in Computer.

Q: Is the hard drive listed in Device Manager?

A: All drives appear in at least one place in Device Manager.

Go to _____ to type **Device Manager** and then launch it. Look in the **Disk Drives** section and, if necessary, click the plus sign to view the full list of devices. If you're uncertain that your drive is listed, safely unplug it and then reconnect it. The entry that changes is your LaCie hard drive.

Q: Is your hard drive listed next to an unusual icon?

A: Windows Device Manager usually provides information about failures with peripherals. While the Device Manager can assist with troubleshooting most problems, it may not display the exact cause or provide a precise solution.

An unusual icon next to the hard drive can reveal a problem. For example, instead of the normal icon based on the type of device, it has an exclamation point, question mark or an X. Right click this icon and then choose **Properties**. The General tab provides a potential reason why the device is not working as expected.

Warranty Information

To benefit from this warranty, please visit LaCie Support at www.lacie.com/us/support where you can find online support and contact information.

Standard warranties vary depending on the product. To verify your product's warranty status and to see which standard warranty is included with your product, type in your product's serial number at www.lacie.com/us/support. If no warranty is listed under your product's name, this means that the warranty has expired.

Legal Information

A standard LaCie limited warranty is included with all products. Please read the terms and conditions below.

LaCie Limited Warranty Policy

LaCie ("LaCie") warrants, to the original purchaser, that this equipment shall be free of defects in materials and workmanship for a period of one (1), two (2), three (3), or five (5) years, depending on the model, from LaCie's date of original shipment when the equipment is used normally and is properly serviced when needed. If you discover a defect covered by the warranty set forth above, your sole and exclusive remedy will be for LaCie, in its sole discretion to (i) repair or replace the product at no charge to you; or, if a repaired unit or replacement product is not available, (ii) to refund the current market value of your product. You acknowledge and agree that replacement product, at the sole option of LaCie, may be a new product or a remanufactured product. In order to receive the remedy set forth above, you must return the product during the warranty period and include with each returned product (i) a copy of your original purchase invoice to verify your warranty; (ii) a Return Material Authorization number; (iii) your name, address and telephone number; (iv) a copy of the bill of sale bearing the appropriate LaCie serial numbers as proof of date of original retail purchase; and (v) a description of the problem. The customer must pay all transportation costs for a returned product. The product will need to be returned to LaCie within the country of original retail purchase. This warranty applies only to hardware products; LaCie software, media, and manuals are licensed and warranted pursuant to separate written agreement. This warranty does not apply if the product has been misused or has been damaged by accident, abuse, misuse, or misapplication; if it has been modified without permission of LaCie; or if any LaCie serial number has been removed or defaced. If a customer has purchased a LaCie Advance Care Option (ACO) to go with this equipment, the ACO shall be valid for three (3) years from activation.

EXCEPT FOR THE LIMITED WARRANTY SET FORTH ABOVE, ALL PRODUCTS ARE SOLD "AS IS" AND LACIE EXPRESSLY DISCLAIMS ALL WARRANTIES OF ANY KIND, WHETHER EXPRESS, IMPLIED OR STATUTORY, INCLUDING THE IMPLIED WARRANTIES OF MERCHANTABILITY, NONINFRINGEMENT AND FITNESS FOR A PARTICULAR PURPOSE. WITHOUT FURTHER LIMITING THE GENERALITY OF THE FOREGOING, DOES NOT WARRANT (1) THE PERFORMANCE OR RESULTS OBTAINED FROM USING THIS PRODUCT, (2) THAT THE

PRODUCT IS APPROPRIATE FOR THE CUSTOMER'S PURPOSES, (3) THE MANUAL IS ERROR FREE, OR (4) THAT NO DATA WILL BE LOST WHILE USING THE PRODUCT. THE ENTIRE RISK AS TO THE RESULTS AND PERFORMANCE IS ASSUMED BY THE CUSTOMER. THE WARRANTY AND REMEDIES SET FORTH ABOVE ARE EXCLUSIVE AND IN LIEU OF ALL OTHERS, ORAL OR WRITTEN, EXPRESS OR IMPLIED.

EXCLUSIONS AND LIMITATIONS

This Limited Warranty applies only to hardware products manufactured by or for LaCie that can be identified by the "LaCie" trademark, trade name, or logo affixed to them. The Limited Warranty does not apply to any non-LaCie hardware products or any software, even if packaged or sold with LaCie hardware. Manufacturers, suppliers, or publishers, other than LaCie, may provide their own warranties to the end user purchaser, but LaCie, in so far as permitted by law, provides their products "as is". Software distributed by LaCie with or without the LaCie brand name (including, but not limited to system software) is not covered under this Limited Warranty. Refer to the licensing agreement accompanying the software for details of your rights with respect to its use.

LaCie does not warrant that the operation of the product will be uninterrupted or error-free. LaCie is not responsible for damage arising from failure to follow instructions relating to the product's use. This warranty does not apply: (a) to consumable parts, unless damage has occurred due to a defect in materials or workmanship; (b) to cosmetic damage, including but not limited to scratches, dents and broken plastic on ports; (c) to damage caused by use with non-LaCie products; (d) to damage caused by accident, abuse, misuse, flood, fire, earthquake or other external causes; (e) to damage caused by operating the product outside the permitted or intended uses described by LaCie; (f) to damage caused by service (including upgrades and expansions) performed by anyone who is not a representative of LaCie or a LaCie Authorized Service Provider; (g) to a product or part that has been modified to alter functionality or capability without the written permission of LaCie; or (h) if any LaCie serial number on the product has been removed or defaced.

No LaCie dealer, agent, or employee is authorized to make any modification, extension, or addition to this warranty.

Any loss, corruption or destruction of data while using a LaCie drive is the sole responsibility of the user, and under no circumstances will LaCie be held liable for the recovery or restoration of this data. To help prevent the loss of your data, LaCie highly recommends that you keep TWO copies of your data; one copy on your external hard disk, for instance, and a second copy either on your internal hard disk or another external hard disk.

LACIE IS NOT RESPONSIBLE FOR SPECIAL, INCIDENTAL, OR CONSEQUENTIAL DAMAGES RESULTING FROM ANY BREACH OF WARRANTY, OR UNDER ANY LEGAL THEORY, INCLUDING LOST PROFITS, DOWNTIME, GOODWILL, DAMAGE TO OR REPLACEMENT OF EQUIPMENT AND PROPERTY, AND ANY COSTS OF RECOVERING, REPROGRAMMING, OR REPRODUCING ANY PROGRAM OR DATA STORED IN OR USED WITH LACIE PRODUCTS EVEN IF IT HAS BEEN ADVISED OF THE POSSIBILITY OF SUCH DAMAGES.

Some states do not allow the exclusion or limitation of implied warranties or liability for incidental or

consequential damages, so the above limitation or exclusion may not apply to you. This warranty gives you specific legal rights, and you may have other rights, which vary from state to state.

Read carefully all information related to warranty and precautions of use of your new LaCie product in the user manual.

DOA

On rare occasions, a newly purchased LaCie product may be delivered in non-working order. We are working to avoid these issues, but unfortunately, these situations may arise from time to time. Within the 15 calendar days of purchase, should you experience an issue with your new LaCie product, we ask you to return the product to the place where it was originally bought. You will be required to give a proof of purchase.

Customer Warning

Please be sure to back up your data before returning your drive to LaCie for repair. LaCie cannot under any circumstances guarantee the integrity of data remaining on a returned drive. We make no provisions for data recovery and cannot be held liable for any data loss on drives or media returned to LaCie.

All products returned to LaCie must be securely packaged in their original box and shipped with postage prepaid, except for Products registered under the Advance Care Option.