

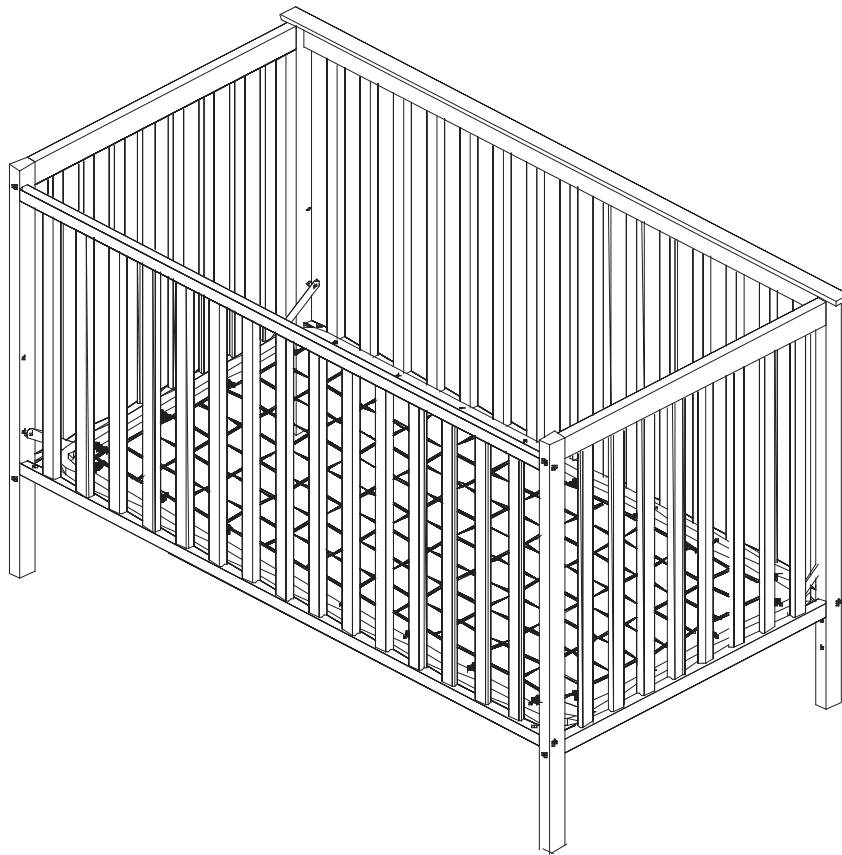

Sheffield

Stages crib Assembly Instructions















CAUTION: Carefully read instructions and procedures for safe operation. Should this product become damaged and/or components are broken, DO NOT USE. Assembly of this product will require two people.

AVERTISSEMENT: Lisez toutes les intructions avant de monter le lit de bébé. Avant d'utiliser ou de monter le lit de bébé, inspectez-le pour vous assurer qu'il n'y a pas de pièces endommagées, d'articulations deserrées, de pieces manquantes ou de bords tranchants. N'utilisez pas le lit de bébé si certaines pièces sont manquantes ou brisées. L'assemblage de ce produit nécessite deux personnes..



Please store this manual in the plastic pouch for future reference.
Veuillez garder ces instruction dans la pochette plastique pour future

WARNING

Failure to follow these warnings and assembly instructions could result in serious injury or death. THIS INSTRUCTION CONTAINS IMPORTANT SAFETY INFORMATION. PLEASE READ AND KEEP FOR FUTURE REFERENCE.

-  Read all instructions before assembling the crib. KEEP INSTRUCTIONS FOR FUTURE USE.
-  The mattress used in this crib should not be more than 6 inches (15cm.) thick and should be of such length and width that the gap between the mattress and the sides of the crib is not more than 1-3/16 inches (3cm.) when the mattress is pushed into the corner of the crib.
-  Infants can suffocate in gaps between crib sides and a mattress that is too small.
-  Check this product for damaged hardware, loose joints, loose bolts or other fasteners, missing parts or sharp edges before and after assembly and frequently during use. DO NOT use the crib if any parts are missing or broken.
-  To obtain replacement parts and instructional literature call the telephone number on this label. DO NOT substitute parts.
-  DO NOT use a water mattress with this crib.
-  Never use plastic shipping bags or other plastic film as mattress covers because they can cause suffocation.
-  If re-finishing, use a non-toxic finish specified for children's products.
-  Do not use this crib if the attached or enclosed instructions cannot be strictly adhered to.
-  Regularly check this product, before placing your child in the crib, that every component is properly and securely in place.
-  To reduce the risk of SIDS, pediatricians recommended healthy infants be placed on their backs to sleep, unless otherwise advised by your physician.
-  Infants can suffocate on soft bedding. Never add a pillow or comforter. Never place additional padding under an infant.
-  Follow warnings on all products in a crib.

STRANGULATION HAZARD:

-  DO NOT place crib near window where cords from blinds or drapes may strangle a child. DO NOT place cords, straps or similar items that could become wound around the child's neck in or near the crib.
-  Strings can cause strangulation! Do not place items with a string around a child's neck, such as hood strings or pacifier cords. Do not suspend strings over a crib or attach strings to toys.
-  To help prevent strangulation, tighten all fasteners. A child can trap parts of the body or clothing on loose fasteners.

FALL HAZARD:

-  Stop using crib when child begins to climb out or reaches the height of 35 in. (89cm).
-  When child is able to pull up to standing position, set mattress to lowest position and remove bumper pads, large toys and

CAUTION: ANY MATTRESS USED IN THIS CRIB SHALL BE AT LEAST 27-1/4 INCHES BY 51-5/8 INCHES (69 X 131 CM) WITH A THICKNESS NOT EXCEEDING 6 INCHES (15 CM).

THIS PRODUCT CONFORMS TO APPLICABLE REGULATIONS OF THE CONSUMER PRODUCT SAFETY

DISTRIBUTED BY :

**Stork Craft Mfg.(USA), Inc.,
3993 Howard Hughes Parkway, Unit#250
Las Vegas, NV USA 89169
TEL: 1 877 274 0277**

Identifying The Parts/ Identification des pièces

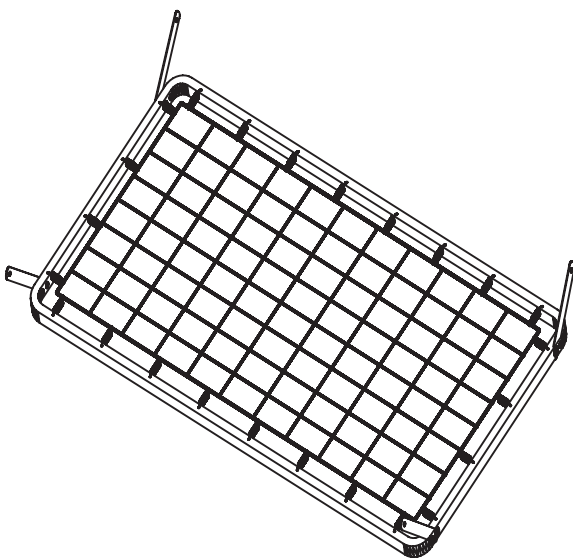
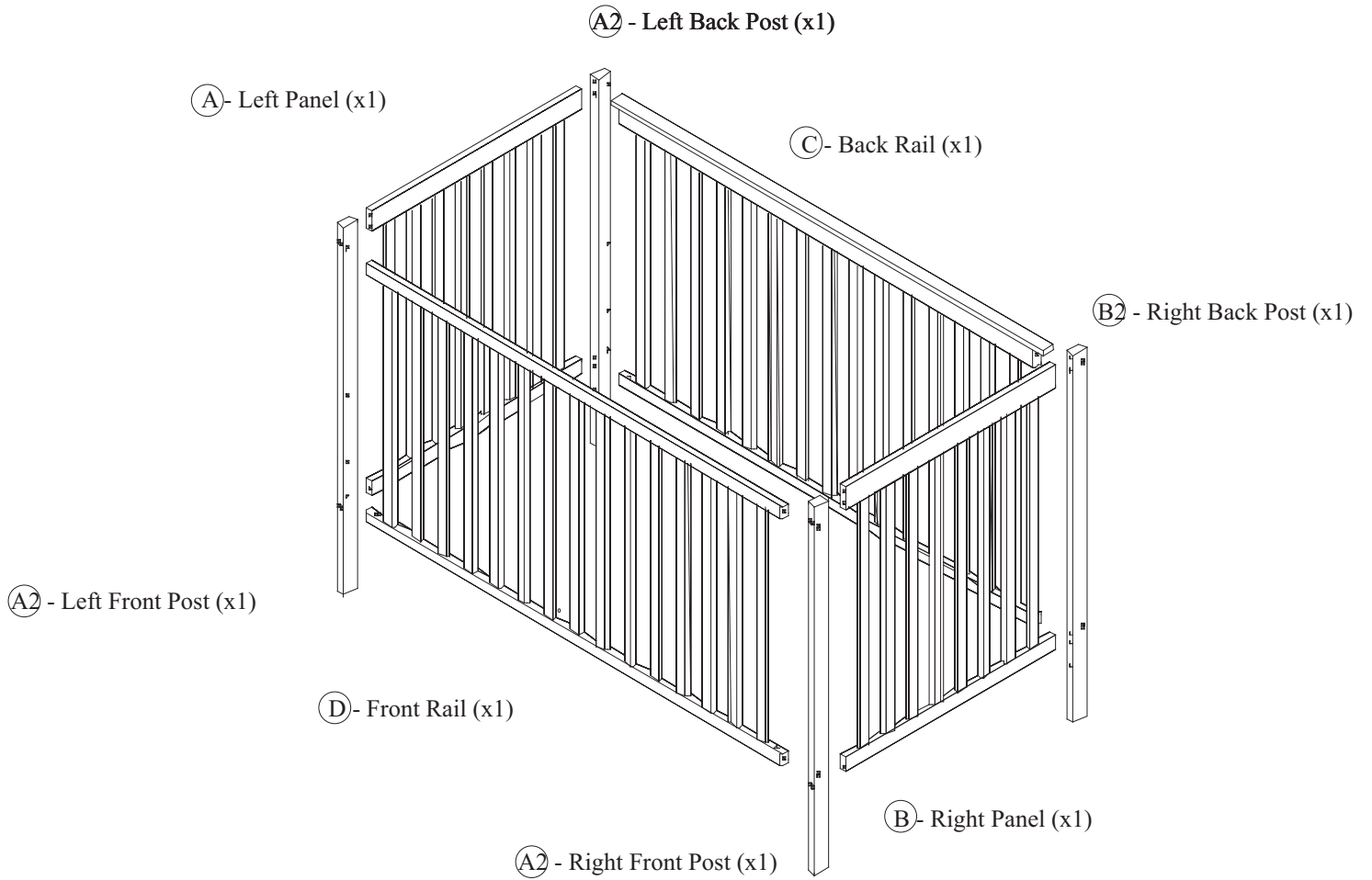

(E) - Mattress Base (x1)

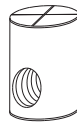

(T) - barrel Nut (x16)

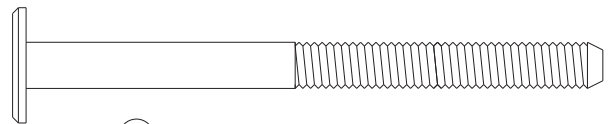

(1) - 1/4" x 3" Bolt (x8)

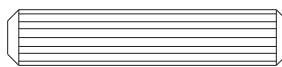

(X) - Wooden Dowel (x4)

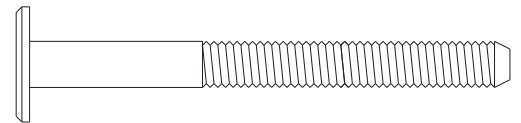

(2) - 1/4" x 2-1/2" Bolts (x8)



Allen Key (included)

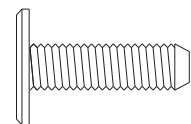

(3) - 1/4" x 3/4" Bolts (x8)

1 ASSEMBLE LEFT & RIGHT PANEL

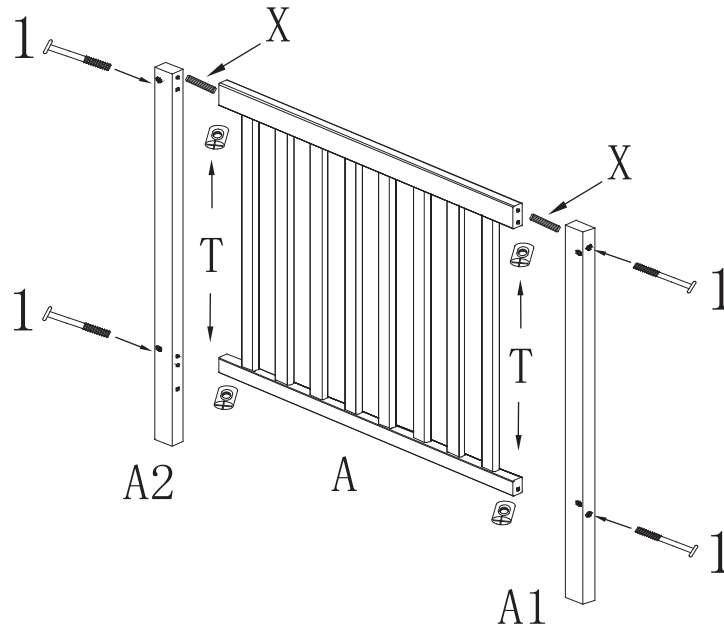

1. Insert Wooden Dowel (X) to top of Front and Back Posts (A1 & A2).
2. Attach Left Panel (A) using the 1/4" x 3" Bolts (1) and 4 Barrel Nuts (T) provided. Repeat the same Procedure for Right Panel.
3. Using the Allen Key, tighten the bolts. DO NOT over-tighten.

2 BACK RAIL ASSEMBLY

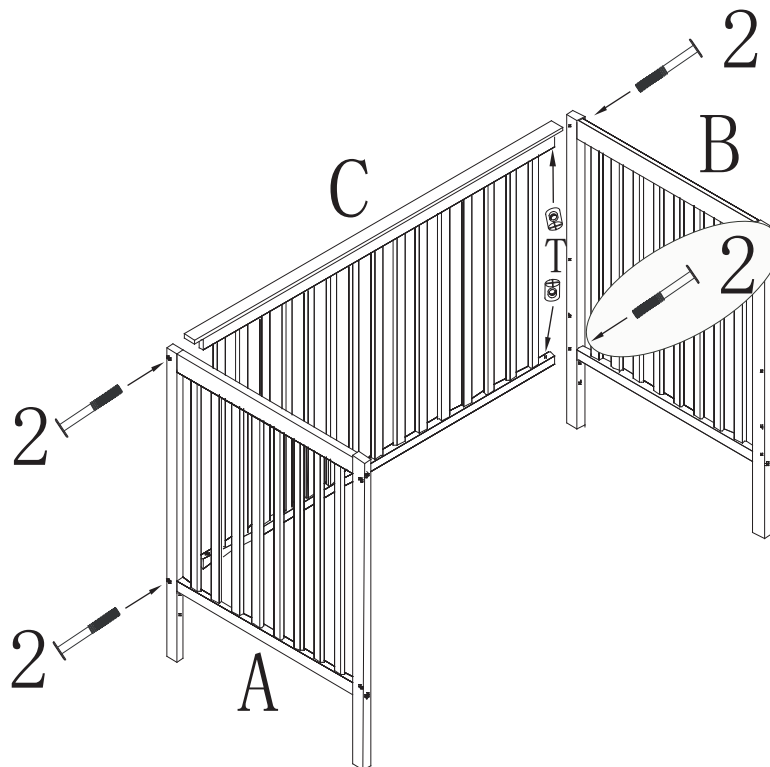

1. Attach Left Panel and Right Panel (A & B) to Back Rail (C) using the 1/4" x 2-1/2" Bolts (2) and Barrel Nuts (T) provided.
2. Using the Allen Key, tighten bolts. DO NOT over-tighten.

3 ASSEMBLE MATTRESS BASE TO CRIB

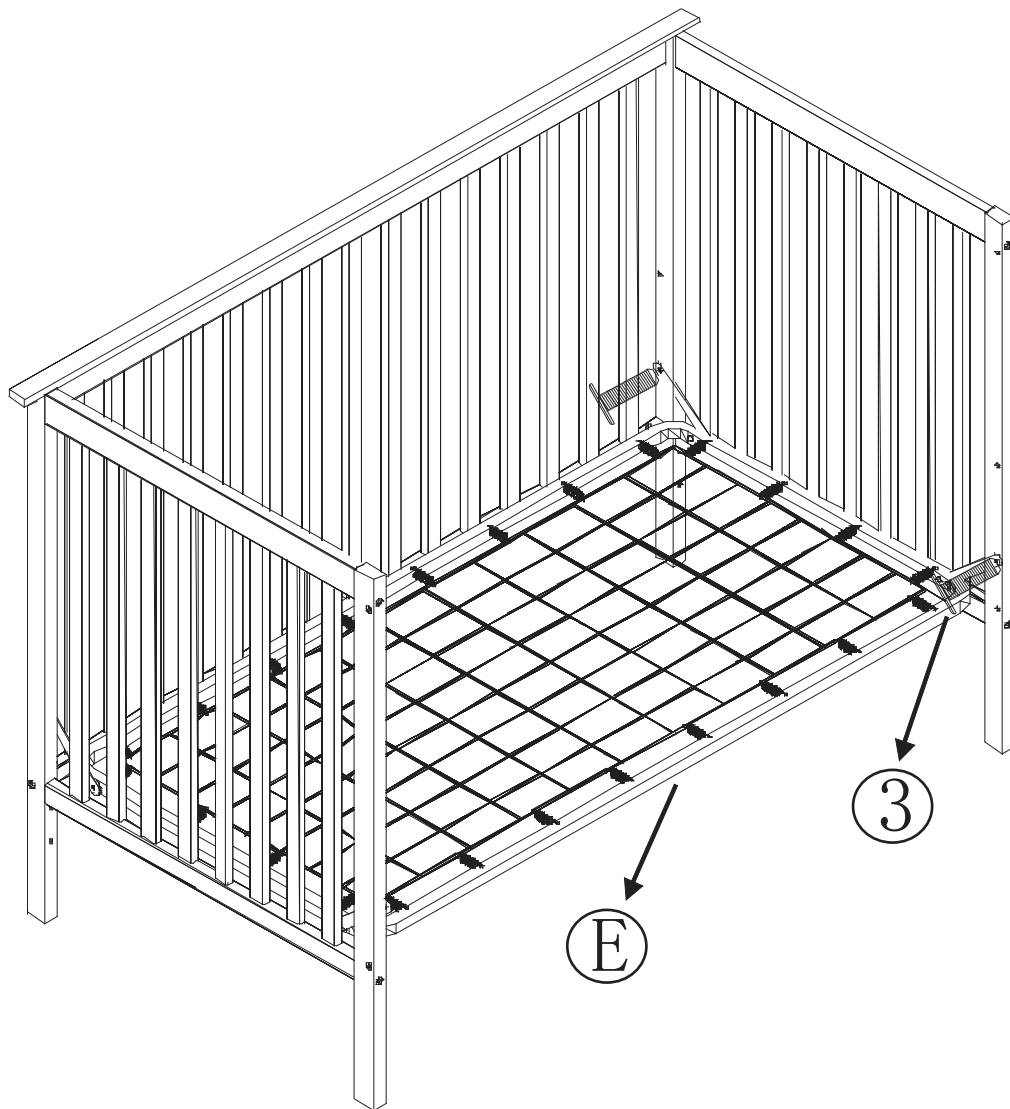

NOTE: This assembly step may require two people. Assemble mattress base in the highest position for a newborn. As baby grows, the mattress base should be lowered to prevent baby from climbing out.

1. Attach base using 1/4" x 3/4" Bolts (3) .
2. DO NOT over-tighten.

4 ASSEMBLE FRONT RAIL

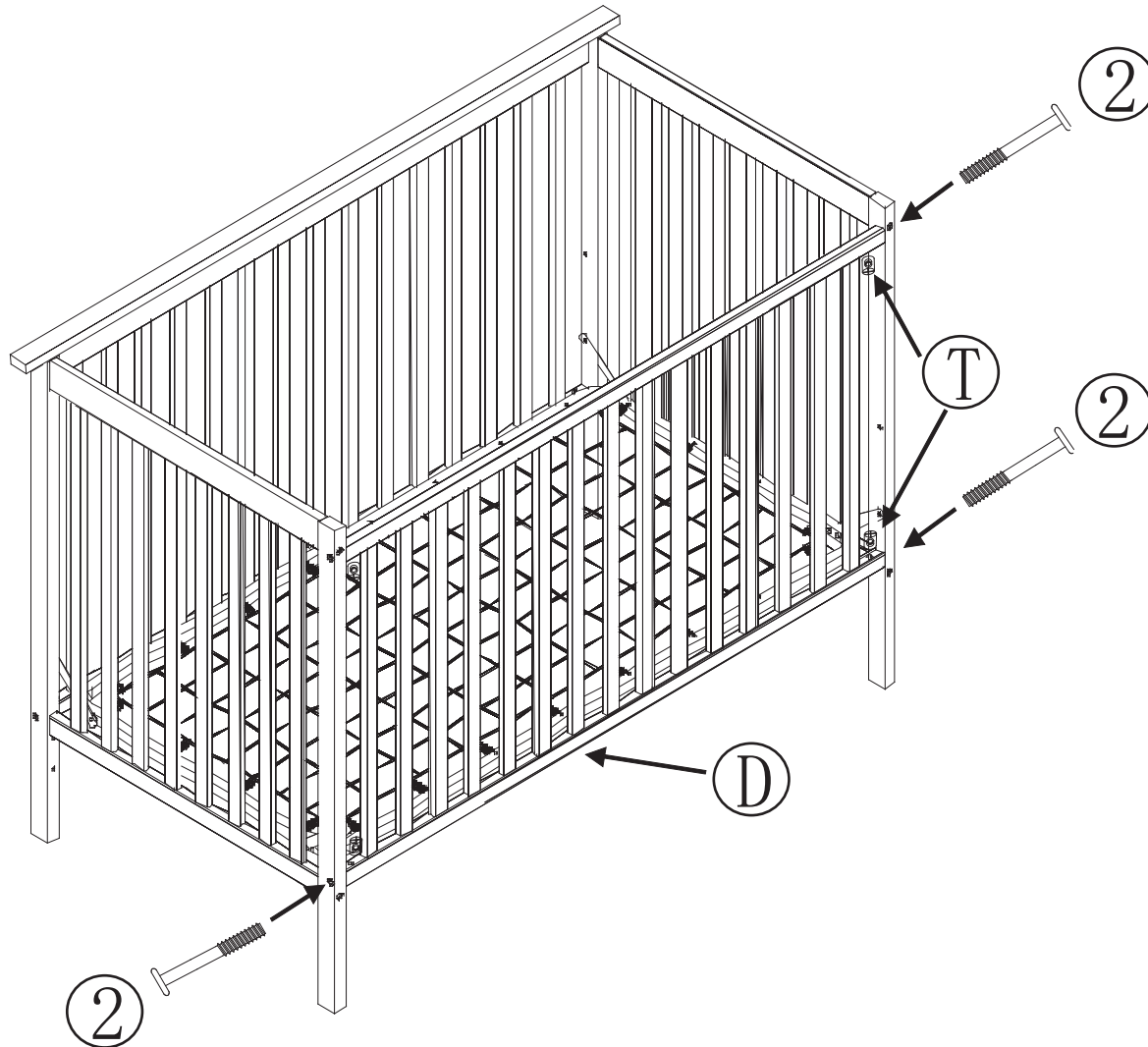

1. Position the Front Rail (D) between the Left Panel and right panel.
2. Attach Front Rail (D) using four 1/4" x 2-1/2" Bolts (2) and four Barrel Nuts (T) provided.
3. Using the Allen Key, tighten bolts. DO NOT over-tighten.

5 TO CONVERT CRIB INTO FULL SIZE HEADBOARD

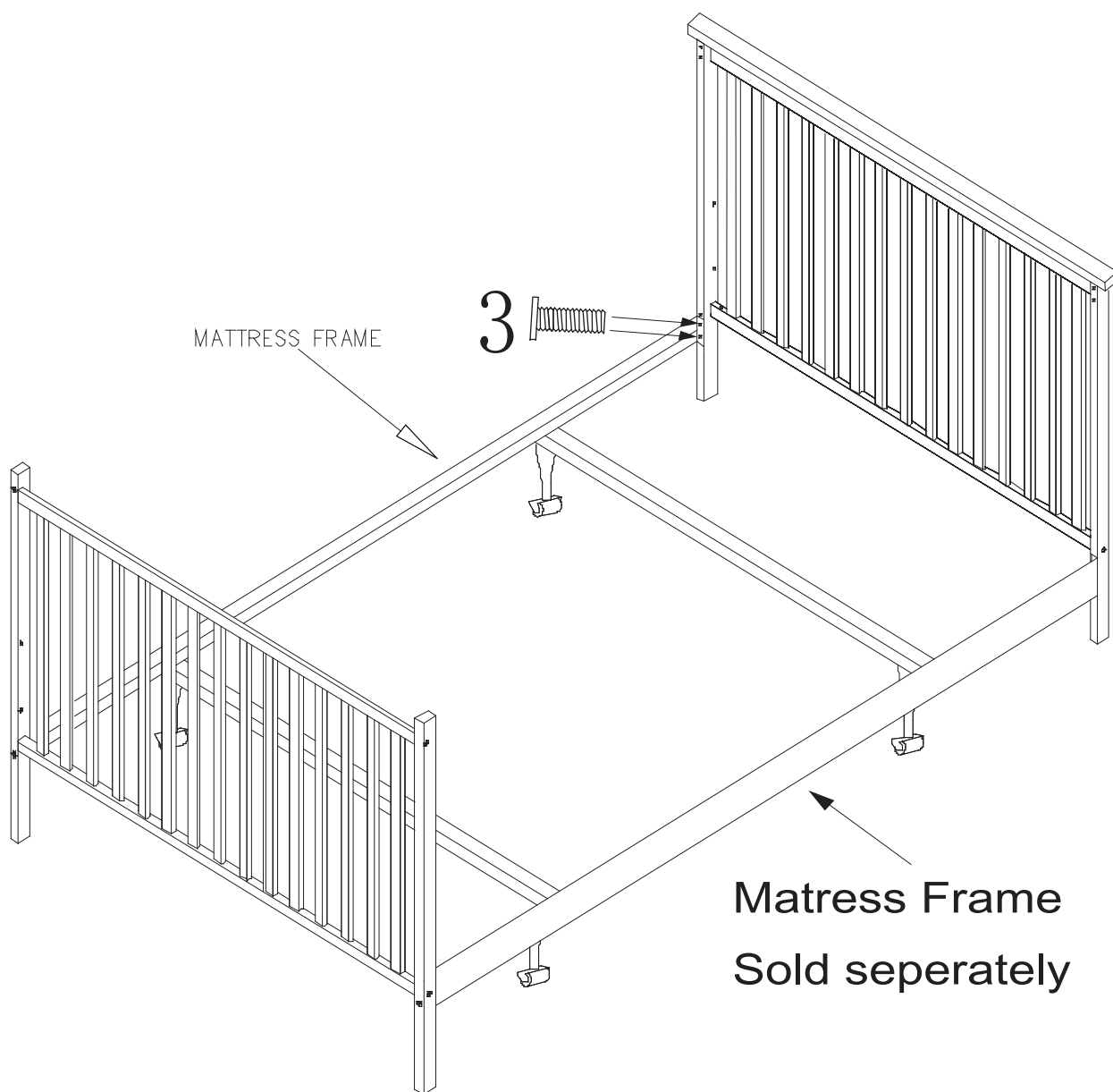

NOTE: Mattress frame has to be purchased separately.

1. The Back Rail becomes a full size Headboard.
2. Attach Mattress Frame to Back Rail using 1/4" x 3/4" Bolts (3) provided.

STORAGE AND CARE DÉMONTAGE DU LIT DE BEBE

DO NOT remove any part that is attached with wood screws, The stationary side rail, mattress base can all be disassembled for storage. Simply review the assembly instructions for each and reverse the order to disassemble. Wipe all parts with a dampened clean cloth. DO NOT use abrasives. To convert to a double bed please follow the instructions in the double bed kit. (MUST BE PURCHASED SEPARATELY)

Démontez votre lit de bébé pour l'entreposer en lieu sûr. Ensuite, enlevez le côté fixe et le support de matelas. Enlevez le côté glissant en le montant le plus haut possible et en appuyant sur le levier sous le cote en T. NOTE: N'enlevez pas les pièces vissées, incluant les côtés en T et les griffes. Nettoyer le lit avec un chiffon humide sans savon. Pour convertir en un lit double, veuillez suivre les instructions incluses avec le kit de conversion pour lit double. (Vendu séparément)

LIMITED ONE YEAR WARRANTY / GARANTIE LIMITEE D'UN AN

Your product is warranted against defects in workmanship or material for ONE YEAR from the date of the original purchase. This warranty shall be limited to repairing or replacing any part of the product which, in the opinion of the company, shall be proved defective in materials or workmanship under normal use and service during the one year warranty period. During the one year warranty period, repair or replacement of parts shall be made at no charge. Date of purchase of the product must be established by production of your sales slip or other satisfactory evidence.

Votre produit a une garantie contre tout vice de matériau ou de fabrication pendant UN AN a compter de la date d'achat. Cette garantie est limitée a la réparation ou du remplacement de toute pièce qui, a l'avis de la société, s'avère défectueuse dans les conditions normales d'utilisation, en raison d'un vice de matériau ou de fabrication pendant la période de garantie d'un an. La société réparera ou remplacera gratuitement les pièces défectueuses. La date d'achat du produit doit être établie en présentant votre reçu de caisse ou autre preuve satisfaisante.

HOW TO GET PROMPT, EFFICIENT SERVICE / POUR UN SERVICE RAPIDE ET EFFICACE

Contact our customer service department. The telephone number and hours of operation are listed below. Please do not return the product to the store where it was originally purchased as they do not stock replacement parts. When calling our customer service department, make sure to mention the model number, country of manufacture and date of manufacture. This information can be found on the lower right hand corner of this instruction sheet. It is company policy to respond to each request as quickly as possible.

Communiquer avec notre service à la clientèle. Le numéro de téléphone et les heures d'ouverture sont indiqués ci-dessous. Ne pas retourner le produit au marchand qui vous l'a vendu étant donné qu'il ne garde pas de pièces de rechange en magasin. S'assurer de mentionner le numéro de modèle, le pays de manufacture et la date de fabrication quand on téléphone au service à la clientèle. Cette information peut être trouvée sur le feuillet d'instruction qui est collé sur le support de matelas (sous le matelas). La société a pour règle de répondre le plus rapidement possible à chaque demande.

Customer Service Direct Telephone line: **1-877-274-0277** Fax **(604) 274-9727**
Hours of operation: 7:00 AM to 3:00 PM, Pacific Standard Time
e-mail: parts@storkcraft.com

Service a la clientèle - Téléphone: **1-877-274-0277** Telecopieur **(604) 274-9727**
Heures d'ouverture: 7h a 15 h 00 (Heure normale du Pacifique)

Distributed by / Distribué par

Stork Craft Mfg.(USA), Inc.,
3993 Howard Hughes Parkway, Unit#250
Las Vegas, NV USA 89169
Tel: 1 877 274 0277