



# formfit

Digital Scale &  
Body Analyzer

Instruction Manual

VG42252-0000

version: 1.0

# Congratulations

on your Vitagoods purchase.

The **formfit** professional scale & measurement system allows you to keep track of your weight, body fat, muscle mass, water weight, and bone density, helping you maintain a healthy lifestyle.

To get the most out of your new digital body analyzer and ensure your safety, read this instruction manual prior to use.

**Safety instructions and symbols are located in the back.**

Please follow these instructions carefully, and keep this manual for future reference.

For assistance,  
call 1-888-870-2132 or visit us at:

**vitagoods.com**

# TABLE OF CONTENTS

Device Components .....	4
Getting Started.....	5
Setting up Users.....	6
Taking a Measurement.....	7
Replacing the Batteries .....	9
2 Year Warranty .....	10
How the <b>formfit</b> Works.....	11
Muscle Mass Percentage .....	12
Body Fat Percentage.....	13
Bone Density.....	14
Water Weight Percentage .....	15
Frequently Asked Questions .....	16
Care & Maintenance.....	17
Caution .....	18
FCC Regulations .....	18
Safety Information .....	20
Warning Indicators.....	20
Device Specifications.....	21
Equipment Classification & General Use .....	22

# DEVICE COMPONENTS



## 1 User Type

choose between male, female, & athlete

## 2 Weight

displays measurement of weight

## 3 Water Weight Percentage

displays the percentage of the weight reading that is water weight

## 4 Units of Measure

allows you to display weight measurements in pounds, kilograms, or stones

## 5 Body Fat Percentage

displays the percentage of the weight reading that is body fat

## 6 Bone Density

displays the percentage of the weight reading that is bone mass

## 7 Muscle Mass

displays the percentage of the weight reading that is muscle mass

## 8 Contact Plates

these stainless steel plates allow a small electrical current needed to perform the analysis to pass into your body

## 9 Up Selection Indicator

allows you to navigate "up" when adjusting settings on the scale

## 10 The Set Button

allows you to enter the scales "settings" mode and to make selections

## 11 Down Selection Indicator

allows you to navigate "down" when adjusting settings on the scale

# GETTING STARTED

## Preparing Your Body Analyzer

1. Open the battery compartment on the scale's underside.
2. Insert batteries (4x AAA) observing the polarity signs (+ and -) inside the battery compartment.
3. Close the battery compartment.
4. Select kg, st, or lb weight mode by pressing the tab on the back of the scale.
5. Position scale on a hard, flat surface.

## Initializing Your Scale

The first time you use your scale and anytime you move your scale it will need to be initialized so that it weighs you properly. Follow these quick steps to initialize your scale (after removing the insulating strip).

1. Place your scale on a hard, flat surface—not carpet.
2. Press down on the center of the platform with your foot, then lift your foot off.
3. "0.0" will display on the screen.
4. Once the scale shuts down, it is ready to use; simply step on the scale to take your measurements.

# SETTING UP USERS

1. Press any button to activate the setup procedure.
2. Within 3 seconds, select a user number by pressing the **Up** or **Down** buttons. Press **Set** to confirm.
3. The male or female symbol will begin to blink. Use the **Up** or **Down** button to cycle through the icons and press the **Set** button to select the one that best identifies you.

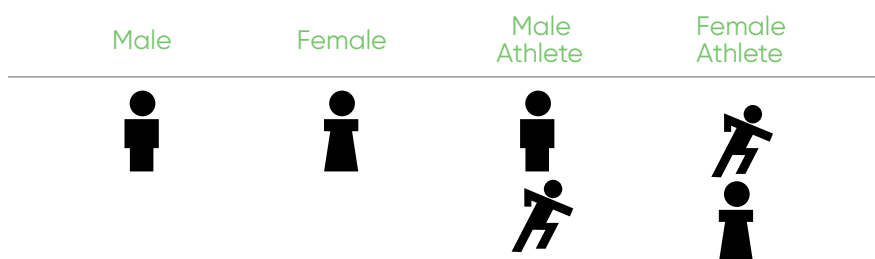

#### Athlete Mode:

An athlete is defined as a person who is involved in intense physical activity for approximately 12 hours per week and who has a resting heart rate of approximately 60 beats per minute or less.

4. The height display will now begin to blink. Press the **Up** and **Down** buttons to adjust to your height then press the **Set** button to confirm.
5. The age display will now begin to blink. Press the **Up** and **Down** buttons to adjust to your age then press the **Set** button to confirm.
6. The display will show "0.0" before turning off. The user settings are now saved.

Repeat procedure to configure up to 8 unique users (ex: P1) or to change specific user details. Once a user has been created it can be modified but not deleted.

# TAKING A MEASUREMENT

## Your First Measurement

1. If you have not taken a measurement before, use the **Up** and **Down** arrows to select the user profile that identifies you.
2. Make sure your scale is on a hard, flat surface (not carpet) and has been initialized.
3. When the screen displays "0.0," step onto the scale with your bare feet and ensure your feet are in good contact with the 4 stainless steel contact pads on the platform.
  - The condition of your skin on the bottom of your feet can affect the reading. To get the most accurate and consistent reading, wipe your feet with a damp cloth, leaving them slightly moist before stepping on the scale.
4. Stand still, and remain on your **formfit** until the complete readout is displayed.
5. Your weight will display, followed by a series of moving measurement indicators.
6. After 2-3 seconds, your weight will be joined by your body fat %, body water %, muscle mass %, and bone density measurements.
7. You may step off of the scale; the measurements will continue to be displayed for 10 seconds, after which time the scale will turn off.

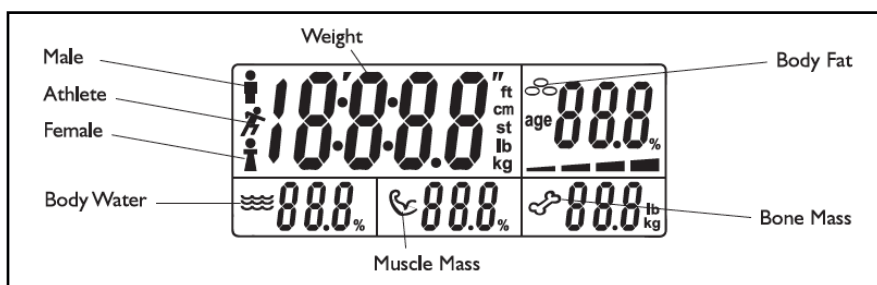

# TAKING A MEASUREMENT

## Every Other Measurement

1. Make sure your scale is on a hard flat surface (not carpet) and has been initialized.
2. The **formfit** uses "Sense-On Technology" and automatic user detection, so simply step onto the platform to take your measurement.
3. If you are taking a complete measurement, be sure to remove your shoes and socks. You must have bare feet to obtain body fat and total body water measurements.
  - The condition of your skin on the bottom of your feet can affect the reading. To get the most accurate and consistent reading, wipe your feet with a damp cloth, leaving them slightly moist before stepping on the scale.
4. Step onto the platform and ensure that your feet are in good contact with the 4 stainless steel contact pads on the platform.
5. Stand still, and remain on your Form Fit until the complete readout is displayed.
6. Your weight will display followed by moving measurement indicators.
7. After 2-3 seconds, your weight will be joined by your body fat %, body water %, muscle mass %, and bone density measurements.
8. You may step off of the scale; the measurements will continue to be displayed for 10 seconds, after which time the scale will turn off.

### **Note:**

When the body fat reading displays, a horizontal bar will appear below the body fat reading. This corresponds to the Low, Normal, Moderate, and High ranges.

# REPLACING THE BATTERIES

When the “**LO**” symbol appears, it is time to replace your batteries. Remember, **Do Not** dispose of the old batteries with regular household waste. Please refer to your local ordinances and recycling instructions regarding disposal of worn batteries.

## Replacing the Batteries

1. Open the Battery Compartment on the bottom of the **formfit**.
2. Remove the old batteries and dispose of them appropriately.
3. Insert the new batteries (4 X AAA) into the battery compartment according to the polarity indicators visible inside the compartment.
4. Once the new batteries are installed, all the digits on the front LCD will light up.
5. Close the battery compartment and wait for the display to show “0.0.”

Unit Selector

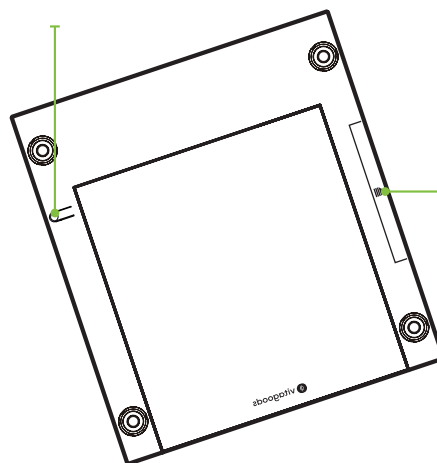

Battery  
Compartment



## ONE-YEAR WARRANTY

This Vitagoods product is warranted to be free of manufacturer's defects in materials or workmanship for one year from the date of purchase. Damage or wear resulting from an accident, misuse, abuse, commercial use, or unauthorized adjustment and/or repair are not covered under this warranty.

Should this product require warranty service (or replacement at our discretion) please contact client service to obtain a Return Merchandise Authorization number (RMA) and return instructions. Proof of purchase is required. Products returned without a Vitagoods generated RMA number will not be accepted and the sender will not receive a refund, replacement, or repaired product.



[info@vitagoods.com](mailto:info@vitagoods.com)

1.888.870.2132

---

There are no express warranties except as listed above. This warranty gives you specific legal rights and you may have other rights which will vary from state to state.

DO NOT RETURN TO RETAILER, PLEASE CONTACT US DIRECTLY FOR WARRANTY SERVICE OR REPAIR, THANK YOU.

## HOW IT WORKS

The **formfit** Digital Scale & Body Analyzer uses BIA (Bio Impedance Analysis) technology which passes an electrical current through the body to estimate body fat mass, lean mass, total body water, and bone mass. The electrical current is small and will not be felt. Contact with the body is made via stainless steel pads on the platform of the scale.

The scale simultaneously calculates your body fat percentage, total body water percentage, bone mass, and muscle mass while measuring your body weight, offering you a more accurate reading of your overall health and fitness.

This scale stores the personal data of up to 8 users. In addition to being a body analyzer, it also can be used as a conventional scale.

*Note: This scale is designed for at-home use and ease of measurement. The Body Fat percentage may not be 100% accurate because this scale does not include handholds that measure electrical currents through the hands. However, it is very consistent. To get the best results from your **formfit**, we recommend getting professionally measured first. Then compare this measurement to your **formfit** reading to track your progress over time.*

# MUSCLE MASS PERCENTAGE

According to the American College of Sports Medicine, lean muscle mass may decrease by nearly 50 percent between the age of 20 and 90. If you do nothing to maintain muscle mass, you could be losing muscle and increasing fat. It is also important to know your muscle mass percentage during weight reduction. At rest, the body burns approximately 110 additional calories for each kilo of muscle gained. Benefits of gaining muscle mass include:

- Reversing the decline in strength, bone density, and muscle mass associated with aging
- Maintenance of flexible joints
- Guided weight reduction when combined with a healthy diet

Muscle Mass Percentage Chart					
Gender	Age	Low (-)	Normal (0)	High (+)	Very High
Female	18-40	<24.4	24.4 - 30.2	30.3 - 35.2	≥35.3
	41-60	<24.2	24.2 - 30.3	30.4 - 35.3	≥35.4
	61-80	<24.0	24.0 - 29.8	29.9 - 34.8	≥34.9
Male	18-40	<33.4	33.4 - 39.4	39.5 - 44.1	≥44.2
	41-60	<33.2	33.2 - 39.2	39.3 - 43.9	≥44.0
	61-80	<33.0	33.0 - 38.7	38.8 - 43.4	≥43.5

# BODY FAT PERCENTAGE

One of the things the human body is made up of is a percentage of fat. Body fat is vital for a healthy, functioning body; however, too much or too little body fat can be unhealthy.

That's why it is important to measure and monitor your body fat percentage. Body fat percentage gives you a better measure of fitness, rather than weight alone. The composition of your weight loss could mean you are losing muscle mass rather than fat. You could still have a high percentage of fat even when a scale indicates you are at a "normal weight."

## Normal healthy range of Body Fat percentage:

### Standard for Men:

Source: University of Illinois Department of Food Science and Human Nutrition. Body Fat Percentage Calculator.

Rating	20-29	30-39	40-49	50-59	60 Plus
Low	<13	<14	<16	<17	<18
Normal	14-20	15-21	17-23	18-24	19-25
Mod. High	21-23	22-24	24-26	25-27	26-28
High	>23	>24	>26	>27	>28

### Standard for Women:

Source: University of Illinois Department of Food Science and Human Nutrition. Body Fat Percentage Calculator.

Rating	20-29	30-39	40-49	50-59	60 Plus
Low	<19	<20	<21	<22	<23
Normal	20-28	21-29	22-30	23-31	24-31
Mod. High	26-31	30-32	31-33	32-33	33-35
High	>31	>32	>33	>34	>35

# BONE DENSITY

Regular exercise and a balanced diet can help maintain healthy bones. Like muscle, bone is a living tissue that can respond to exercise by becoming stronger, and it can become weaker from lack of exercise. For most people, bone density peaks in their thirties and then begins to decline, but regular exercise can help prevent the decline.

Calcium and Vitamin D (good sources of which are dairy products, green leafy vegetables, and fish) contribute to healthy bones.

The bone mass readings given by this product are an estimation of the amount of bone in your body. Those with osteoporosis or low bone densities may not get accurate estimations. If you have any concerns regarding your bones you should consult your doctor.

Rating	20-29	30-39	40-49	50-59	60 Plus
Low	<7.6	<7.4	<7.0	<6.6	<6.3
Normal	7.6-8.4	7.4-8.2	7-7.8	6.6-7.4	6.3-7.1
High	>8.5	>8.3	>7.9	>7.5	>7.2

# BODY WATER

Body water is the single most important factor of body weight. It represents over half of your total weight and almost two-thirds of your lean body mass. Body weight is also a key contributor to cellular functions and plays a vital role in regulating body temperature, mostly through perspiration.

The combination of your weight and fat measurements could appear to be "normal" but your body hydration level could be insufficient for healthy living.

Body water measurement results are influenced by the proportion of body fat and muscle. If the proportion of body fat is high, or the proportion of muscle is low, then the body water results will tend to be low.

Short term fluctuations of body weight, body fat, and body water are normal; we suggest you chart your progress over time, rather than focus on a single day's reading.

## Normal healthy range of water weight percentage:

	Body Fat & Range	Optimal Total Body Water & Range
Men	4-14%	70-63%
	15-21%	63-57%
	22-24%	55-37%
	25 and Over	70-58%
Women	4-20%	70-58%
	21-29%	58-52%
	30-32%	52-49%
	33 and Over	49-37%

### Total Body Water Percentage

Source: Derived from Wang & Deurenberg: "Hydration of fat-free body mass." American Journal. Clin Nutr 1999;69:833-841

# FREQUENTLY ASKED QUESTIONS



## How exactly is my body fat and water being measured?

The **formfit** uses a measurement method known as Bio-electrical Impedance Analysis (BIA). A minute current is sent through your body, via your feet and legs. This current flows easily through the lean muscular tissue, which has a high fluid content, but not easily through fat. By measuring your body's impedance (its resistance to the current), the quantity of muscle can be determined, and the quantity of fat and water can then be estimated.

## What is the value of the current passing through me when the measurement is taken? Is it safe?

The current is less than 1mA. You may not be able to feel it, but please note that this device should not be used by anyone with an internal electronic medical device, such as a pacemaker, as a precaution against disruption to that device.

## If I measure my body fat and water at different times during a day, it can vary quite considerably. Which value is correct?

Your body fat percentage reading varies with body water content, and the latter changes throughout the course of the day. There is no right or wrong time of the day to take a reading, but aiming to take measurements at a regular time when you consider your body to be normally hydrated can help. It is not recommended to take readings after having a bath or sauna, following intensive exercise, or within 1-2 hours of drinking in quantity or eating a meal.

## Is it possible to get a different reading when using a body analyzer from another manufacturer?

Different body analyzers take measurements around different parts of the body and use different mathematic algorithms to calculate the percentage of body fat. The best advice is not to make comparisons from one device to another, but to use the same device each time to monitor any change.

## What should I do if my body fat reading is very 'high'?

A sensible diet, fluid intake, and exercise program can reduce your body fat percentage. Professional medical guidance should be sought before embarking on such a program.

## Why are the body fat percentage ranges for men and women so different?

Women naturally carry a higher percentage of fat than men, because the make-up of the body is different.

## How do I use my formfit while pregnant?

During pregnancy, a woman's body composition changes considerably in order to support the developing child. Under the circumstances, body fat percentage readings could be inaccurate and misleading.

# CARE & MAINTAINANCE



- Clean exposed parts with a soft, slightly damp cloth.
- Never use detergents, excess water, treated cloths, harsh cleaning agents, or sprays.
- Do not immerse the scale in water.
- Treat your scale with care. It contains sensitive electronic parts. Avoid rough treatment.
- Do not jump on, drop, or kick the scale. Treat it with care to ensure the best performance.
- Do not store the scale where you store cleaning chemicals. The vapors from some household products may affect the electronic components of your scale.
- Do not attempt to lubricate, disassemble, or open the scale casing as this will void your warranty.
- Always weigh yourself on the same scale placed on the same floor surface.
- Do not compare weight readings from one scale to another, as some differences will exist due to manufacturing tolerances.
- Placing your scale on a hard, even floor will ensure the greatest accuracy and consistency.
- It is recommended that you measure at the same time of day, preferably early evening before a meal for the most consistent results.
- Your scale rounds up or down to the nearest increment.
- If you weigh yourself twice and get two different readings, your weight lies between the two.
- Do not dispose of batteries in fire. Batteries may explode or leak. Remove the batteries if the scale will not be used for a long period.

# CAUTION



BIA (Bio-electrical Impedance Analysis) method determines your body fat percentage by sending a harmless signal through the body.

**This device should not be used by anyone with an internal electronic medical device**, such as a pacemaker, as a precaution against disruption to that device.

If in doubt, contact your physician.

- ⚠ This product is for domestic use only.
- ⚠ Professional medical guidance should always be sought before embarking on diet and exercise programs.
- ⚠ **Pregnant women should consult their doctor before use.**



## FCC REGULATIONS

This device complies with Part 15 of the FCC Rules. Operation is subject to the following two conditions: (1) this device may not cause harmful interference, and (2) this device must accept any interference received, including interference that may cause undesired operation.

Radio Frequency Interface Requirements - FCC

Note: This equipment has been tested and found to comply with the limits for a Class B digital device, pursuant to Part 15 of the FCC rules. These limits are designed to provide reasonable protection against harmful interference in a residential installation. This equipment generates, uses and can radiate radio frequency energy and, if not installed and used in accordance with the instructions, may cause harmful interference to radio communications. However there is no guarantee that interference will not occur in a particular installation. If this equipment does cause harmful interference to radio or television reception, which can be determined by turning the equipment off and on, the user is encouraged to try to correct the interference by one or more of the following measures:

- Reorient or relocate the receiving antenna;
- Increase the separation between the equipment and receiver;
- Connect the equipment into an outlet on a circuit different from that to which the receiver is connected;
- Consult the dealer or an experienced radio / TV technician for help.

Radio Transmitters (Part 15)

This device complies with Part 15 of the FCC Rules. Operation is subject to the following two conditions: (1) this device may not cause harmful interference, and (2) this device must accept any interference received, including interference that may cause undesired operation.

Changes or modifications not expressly approved by the party responsible for compliance could void the user's authority to operate the equipment.

Safety Information

Reducing RF Exposure - Use Properly

Only operate the device in accordance with the instructions supplied.

This device complies with FCC radiation exposure limits set forth for an uncontrolled environment.

# SAFETY INFORMATION



The **formfit** Digital Scale & Body Analyzer allows you to track and analyze several key components of your weight. It is intended for use by adults and it is not intended for use on infants and children. This device is designed for home use only.

## CAUTION





As instructed on page 1, read this user manual thoroughly before use. This device is designed and manufactured to operate within defined limits. Misuse may result in harm. The following should be observed for best use and to maintain your device:

- This device is intended solely to monitor and determine weight.
- Its sole function is measurement.
- Monitoring weight with this device does not equate to a medical diagnosis.
- Keep the unit out of reach of infants or children.
- Use only accessories and detachable parts specified and authorized by the manufacturer. Not doing so may cause damage to the unit or danger to you.
- Avoid using this device on slippery or wet floors, or while you are still wet from the bath or shower.
- Do not store this device where it can be exposed to extreme temperatures, humidity, moisture, sunlight, dust or where you store chemicals and cleaners.

**PREGNANT WOMEN SHOULD CONSULT THEIR DOCTOR BEFORE USE.**

# SAFETY INFORMATION



Symbol	Description
	The Operation Guide Must be Read
<b>SN</b>	Serial Number
	Manufacturer
	Direct Current
<b>CE</b>	Complies with EU Requirements
	Indoor Use Only
	ENVIRONMENT PROTECTION - Waste electrical products should not be disposed of with household waste. Please recycle where facilities exist. Check with your local authority or retailer for recycling advice

## WARNING INDICATORS

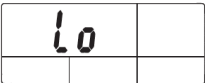
Symbol	Description
	Overload Warning. The maximum weighing capacity of the scale has been exceeded. Remove the weight immediately; otherwise, permanent damage to the scale will occur.
	Low battery warning. Replace the batteries. Always replace all the worn batteries at the same time; do not combine old and new batteries.

# DEVICE SPECIFICATIONS



Product Name	<b>formfit</b> Digital Scale & Body Analyzer - VG42252-0000
Dimensions	12.63 in x 12.88 in x .94 in (Approx. 321mm x 327mm x 24mm)
Net Weight	4.2 lbs (Approx 1.91 kg)
Display	Digital LCD, V.A. = 2.83 in (L) x 1.38 in (W)
Measurement Units	(lb/in), (kg/cm) or (st/in)
Measurement Range	5 kg to 150 kg / 0 st: 11 lb to 23 st: 8 lb / 11 lb to 397 lb
Weight Capacity	150 kg; 397 lb; 28 st 5 lb
Weight Graduation	kg: 0.1 kg / lb: 0.2 lb / st: 0.2 lb (<20 st); 1 lb (≥ 20st)
Height Range	3' 3.5" - 8' 2.5" (100cm - 250cm)
Body Fat % Range	5 - 60% in graduations of 0.1%
Total Body Water % Range	20 - 80% in graduations of 0.1%
Muscle Mass % Range	10 - 80% in graduations of 0.1%
Bone Mass % Range	0.5 - 10 kg in graduations of 0.1kg
Normal Mode Age Range	18 years of age or older
Number of Users	8
Power Source	4 AAA Batteries
Auto-On	SENSE ON Technology
Auto-Off	Automatic Shut-off
Accessories	(1) Instruction Manual + (1) Insert Card

Protection against ingress of water: IP21 | Software Version: A09 | Degree of Protection: Type BF Applied Part

# EQUIPMENT CLASSIFICATION &

EQUIPMENT and its APPLIED PARTS shall be classified by marking and /or identification as described in Clause 6.

This includes:

- 5.1 According to the type of protection against electric shock:  
a) EQUIPMENT energized from an external electrical power source:  
– CLASS I EQUIPMENT;  
– CLASS II EQUIPMENT.  
b) INTERNALLY POWERED EQUIPMENT.
- 5.2 According to the degree of protection against electric shock:  
– TYPE B APPLIED PART;  
– TYPE BF APPLIED PART;  
– TYPE CF APPLIED PART.
- 5.3 According to the degree of protection against ingress of water as detailed in the current edition of IEC 529[see 6.1 1)].
- 5.4 According to the method(s) of sterilization or disinfection recommended by the manufacturer.
- 5.5 According to the degree of safety of application in the presence of a FLAMMABLE ANAESTHETIC MIXTURE WITH AIR or WITH OXYGEN OR NITROUS OXIDE:  
– EQUIPMENT not suitable for use in the presence of a FLAMMABLE ANAESTHETIC MIXTURE WITH AIR or WITH OXYGEN OR NITROUS OXIDE;  
– CATEGORY AP EQUIPMENT;  
– CATEGORY APG EQUIPMENT.
- 5.5 According to the mode of operation:  
– CONTINUOUS OPERATION;  
– SHORT-TIME OPERATION;  
– INTERMITTENT OPERATION;  
– CONTINUOUS OPERATION WITH SHORT-TIME LOADING;  
– CONTINUOUS OPERATION WITH INTERMITTENT LOADING.
- 6.8 ACCOMPANYING DOCUMENTS
- 6.8.1\* General EQUIPMENT shall be accompanied by documents containing at least instructions for use, a technical description and an address to which the USER can refer. The ACCOMPANYING DOCUMENTS shall be regarded as a component part of EQUIPMENT.  
All applicable classifications specified in Clause 5 shall be included in both the instructions for use and the technical description, if separable. All markings specified in Sub-clause 6.1 shall be included in full in the ACCOMPANYING DOCUMENTS if they have not been permanently affixed to EQUIPMENT by the manufacturer. See also Sub-clause 6.1 d). Warning statements and the explanation of warning symbols (marked on the EQUIPMENT) shall be provided in the ACCOMPANYING DOCUMENTS.
- 6.8.2 Instructions for use
- a) \*General information
- Instructions for use shall state the function and intended application of the EQUIPMENT.
  - Instructions for use shall contain all information necessary to operate the EQUIPMENT in accordance with its specification. This shall include explanation of the function of controls, displays and signals, the sequence of operation, connection and disconnection of detachable parts and ACCESSORIES, replacement of material which is consumed during operation.
  - Instructions for use shall provide the USER or OPERATOR with information regarding potential electromagnetic or other interference between the EQUIPMENT and other devices together with advice regarding avoidance of such interference.
  - Instructions for use shall include indications on recognized ACCESSORIES, detachable parts and materials, if the use of other parts or materials can degrade minimum safety.
  - Instructions for use shall instruct the USER or OPERATOR in sufficient detail concerning cleaning, preventive inspection and maintenance to be performed by him, including the frequency of such maintenance. Such instructions shall provide information for the safe performance of routine maintenance. Additionally, instructions for use shall identify the parts on which preventive inspection and maintenance shall be performed by other persons, including the periods to be applied, but not necessarily including details about the actual performance of such maintenance.
  - the meaning of figures, symbols, warning statements and abbreviations on EQUIPMENT shall be explained in the instructions for use.
- b) \*Responsibility of the manufacturer Not used (see Appendix A).
- c) SIGNAL OUTPUT and SIGNAL INPUT PARTS If a SIGNAL OUTPUT or SIGNAL INPUT PART is intended only for connection to specified EQUIPMENT complying with the requirements of this Standard, this shall be stated in the instructions for use
- d) Cleaning, disinfection and sterilization of parts in contact with the PATIENT For EQUIPMENT parts which come into contact with the PATIENT during NORMAL USE, instructions for use shall contain details about cleaning or disinfection or sterilization methods that may be

# GENERAL USE

used (see also Sub-clause 44.7) or, where necessary, identify suitable sterilization agents, and list the temperature, pressure, humidity and time limits which such EQUIPMENT parts can tolerate.

- e) Mains operated EQUIPMENT with additional power source Instructions for use of mains operated EQUIPMENT containing an additional power source not automatically maintained in a fully usable condition shall contain a warning statement referring to the necessity for periodical checking or replacement of such an additional power source. If CLASS I EQUIPMENT is specified for operation connected to a SUPPLY MAINS and alternatively using an INTERNAL ELECTRICAL POWER SOURCE, instructions for use shall contain a statement saying that where the integrity of the external protective conductor in the installation or its arrangement is in doubt, EQUIPMENT shall be operated from its INTERNAL ELECTRICAL POWER SOURCE.
- f) Removal of primary batteries  
Instructions for use of EQUIPMENT containing primary batteries shall contain a warning to remove these batteries if EQUIPMENT is not likely to be used for some time, unless there is no risk of a SAFETY HAZARD arising.
- g) Rechargeable batteries  
Instructions for use of EQUIPMENT containing rechargeable batteries shall contain instructions to ensure safe use and adequate maintenance.
- h) EQUIPMENT with a specified power supply or battery charger Instructions for use shall identify power supplies or battery chargers necessary to ensure compliance with the requirements of this Standard.
- j) Environmental protection Instructions for use shall:
  - identify any risks associated with the disposal of waste products, residues, etc. and of the EQUIPMENT and ACCESSORIES at the end of their useful lives;
  - provide advice on minimizing these risks.

## 6.8.3 Technical description

### a) \*General

The technical description shall provide all data, which is essential for safe operation.

This shall include:

- data mentioned in sub-clause 6.1;
- all characteristics of the EQUIPMENT, including range(s), accuracy, and precision of the displayed values or an indication where they can be found. In addition to details required to be included in instructions for use, the technical description shall state whether particular measures or particular conditions are to be observed for installing EQUIPMENT and bringing EQUIPMENT into use.
- b) Replacement of fuses and other parts
  - If the type and rating of fuses utilized in the mains supply circuit external to PERMANENTLY INSTALLED EQUIPMENT is not apparent from the information concerning RATED current and mode of operation of EQUIPMENT, the required type and rating of fuses shall be indicated in at least the technical description.
  - The technical description shall contain instructions for replacement of interchangeable and/or detachable parts which are subject to deterioration during

### NORMAL USE.

- c) Circuit diagrams, component part lists, etc. The technical description shall contain a statement that the supplier will make available on request circuit diagrams, component part lists, descriptions, calibration instructions, or other information which will assist the USER's appropriately qualified technical personnel to repair those parts of EQUIPMENT which are designated by the manufacturer as repairable.
- d) Environmental conditions for transport and storage The technical description shall contain a specification of the permissible environmental conditions for transport and storage which shall be repeated on the outside of the packaging of the EQUIPMENT [see Sub-clause 6.1 v)]

### 6.8.4 Not used.

### 6.8.5 Not used.

Compliance with the requirements of Sub-clause 6.8 is checked by inspection of the ACCOMPANYING DOCUMENTS.

<b>Working environment</b>	Temperature: 5°C to 40°C    Relative Humidity ≤90%RH Atmospheric pressure: 86kPa to 106kPa
<b>Storage environment</b>	Temperature: -20°C to 60°C    Relative Humidity ≤90%RH Atmospheric pressure: 50kPa to 106kPa

DISTRIBUTED BY: DASTMALCHI, LLC.  
4490 VON KARMAN AVE, SUITE 150  
NEWPORT BEACH, CA 92660



[vitagoods.com](http://vitagoods.com)