

Virtual Reality Integrated Headset

User Manual



BENEVE

Please read this manual before operating your device
and keep it for future reference

Table of Contents

Before Use	1
1. OVERVIEW	2
2. WHAT'S INSIDE	5
3. INSTRUCTIONS	6
3.1 Attention.....	6
3.2 Charge the Device.....	7
3.3 Connect with Computer	8
3.4 TF Card Backup (Micro SD).....	8
3.5 Connecting Earphone.....	8
3.6 HDMI Cable.....	8
4. BASIC OPERATIONS	8
5. HOME SCREEN	9
6. LOCAL APPS	9
6.1 Media Player	10
7. ONLINE THEATER	11
7.1 Main Screen Operation.....	11
7.2 Play Screen Operation.....	12
8. ONLINE PANORAMA VIDEO.....	13
8.1 Main Page Operation.....	13
8.2 Playing Screen	14
9. PHOTOS	15





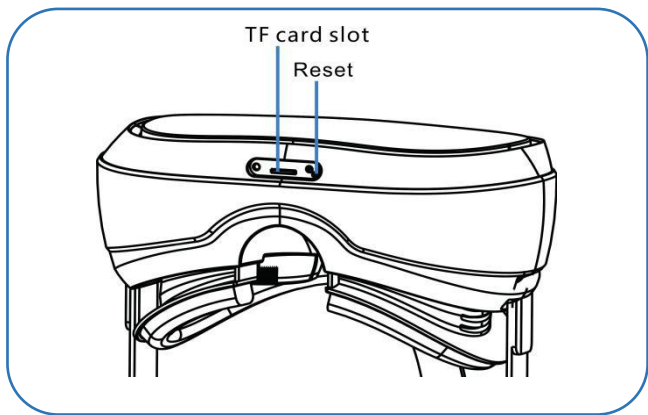
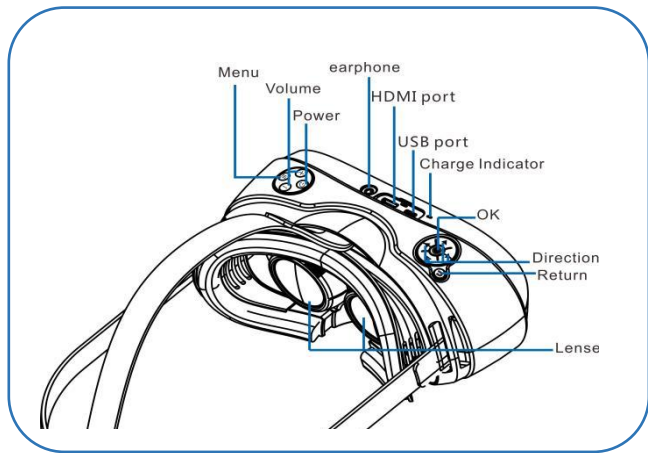

10. TOOLS	16
10.1 Setting.....	17
Bluetooth	17
General	18
Wireless Network.....	18
System	18
Account	18
10.2 Local Application (refer to 6 local App)	18
10.3 Store	18
10.4 HDMI (refer to 3.6).....	18
10.5 Files Manager.....	19

Before Use

- People who are prone to motion sickness in the real world also have a heightened risk of experiencing discomfort while using the VR device. Such individuals should take extra care to read and follow these warnings carefully.
- We recommend consulting with a doctor before using the VR device if you are pregnant, elderly, have psychiatric disorders, suffer from a heart condition, have pre-existing binocular vision abnormalities or suffer from a heart condition or other serious medical condition.
- Do not use VR if you have symptoms of squint, amblyopia, or anisometropia. Using the VR may aggravate these symptoms.
- Do not use the VR device when it is hot as this may cause mild burns. To prevent any injuries, take frequent breaks when using the VR.
- Make sure the VR is level and secured comfortably on your head, and that you see a single, clear image. If you wear VR tilted to one side, you may feel discomfort.
- Just as with the symptoms people can experience after they disembark a cruise ship, symptoms of virtual reality exposure can persist and become more apparent hours after use.
- These post-use symptoms can include the symptoms above, as well as excessive drowsiness and decreased ability to multi-task. These symptoms may put you at an increased risk of injury when engaging in normal activities in the real world.

1. OVERVIEW



	POWER	Hold 3 seconds to turn on/off, quick click to sleep/restart. Hold 10 seconds to shutdown.
	VOLUME	Press keys + or - to adjust the volume.
	MENU	A. Hold the menu button 3 seconds to recall home screen and on-screen pointer in front of you if they are rifting; B. press the menu button to adjust brightness, exit application, switch on-screen pointer, switch VR mode during playing.
	OK	Press OK button to enter menu, video, APP and confirm the operation.
	DIRECTION	Press four direction buttons in a variety of applications and games to turn pages or control directions.
	BACK	Press to return to the previous screen.

Reset: If VR crashes or stuck , press reset button for 2 seconds to force shutdown.

Strap: Slide the opposite end of three head straps through the hole on VR and secure the Velcro tip to the strap. Each strap contains a smaller velcro tip.

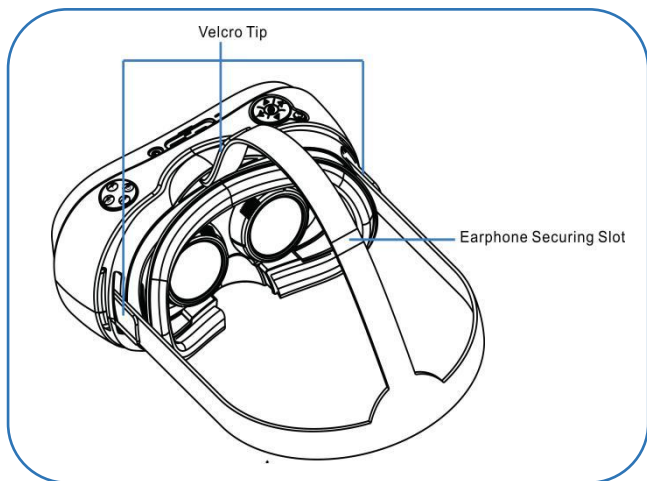

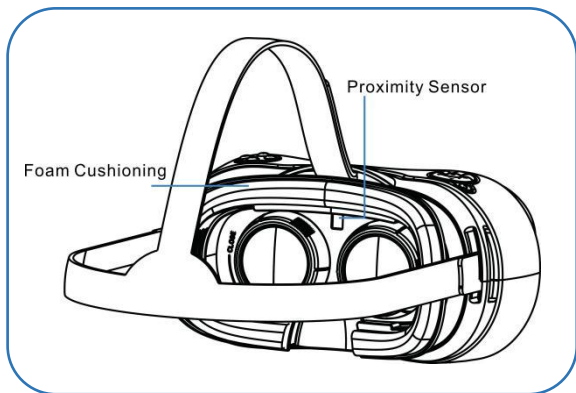

2. WHAT'S INSIDE



VR all-in-one



Earphone



USB2.0 Cable



BT controller (optional)



Adapter



Manual



Cleaning Cloth



HMDI cable (optional)

3.1 Attention

- Remove the lens protector to get clear visibility.
- Keep the lenses clean and protect them from getting scratched. If the lenses get dirty or steam up, clean them with the lens cleaning cloth.
- The foam cushioning may get dirty if your face is sweating while wearing the VR. Doing so may deteriorate the quality of the foam cushioning. Ensure that you keep your face clean and dry when wearing the VR.
- When you are not wearing the VR, do not place objects before VR's proximity sensor. Doing so may cause the proximity sensor to remain on and drain the battery.
- We suggest you to use original power adapter and cables.
- Put the device in cool and dry place for safe storage.
- If VR get stuck or software problem appears, please poke the reset hole for 2 seconds to force shutdown and then press power button to restart after 10 seconds.
- Please check if the top sponge block the Proximity Sensor when you come across the black screen or sleep mode during the using process of the VR device. Please move the sponge as Picture 1 suggest until the sponge doesn't block the Sensor at all.

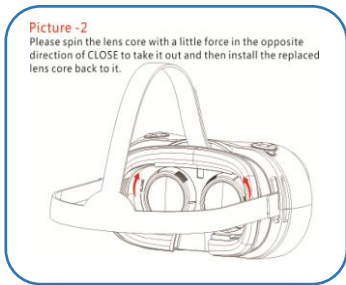
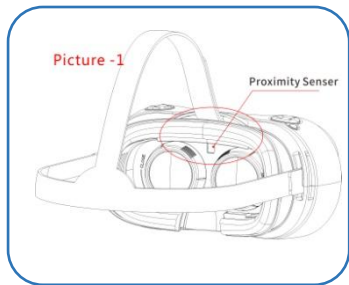

- There is an extra pair of high degree of myopia lens with the device. We suggest you don't have to replace the lens if you are lower than 300 degrees; please change the lens as the picture 2 suggests if you are higher than 300 degrees and found the screen is blurry or can't see it clearly. Please remove the protective film inside and outside the lens before you change them. Move over, you may feel a little bit dizzy after you change into high degree of myopia lens and it's a normal situation. Your eyes need to get used to them.

3.2 Charge the Device

Please use the original power adapter and cable.

Power off the device before you charge it. The red indicator lights will up while charging; the green indicator lights will up if fully charged.

Please charge the device before battery lower than 4%. If battery is used up, keep charging at least 10 minutes before start again.

3.3 Connect with Computer

Connect computer and VR by USB cable we offered, find the disk in My Computer---Removable Device, then transfer the data freely.

3.4 TF Card Backup (Micro SD)

Insert the TF card to the slot with teeth side facing foam cushioning, the VR will read the card automatically, it could be found in file Management—Storage.

3.5 Connecting Earphone

One 3.5mm earphone is included with the VR. Insert the earphone to headset jack.

3.6 HDMI Cable

Connect HDMI with computer and the other side to VR. Goes to VR home page—Tool—HDMI, The content on external device will be shown on VR.

4. BASIC OPERATIONS

- Move your to place on-screen pointer onto a desired item, click OK on VR to confirm
- Generally OK/BACK/MENU buttons are universal buttons during whole operations.
- Press OK button to enter submenu or confirm related function.
- Press RETURN button to exit applications or back from submenu to previous menu.

- Press MENU button to call up the system menu, which including brightness adjustment /close app.
- Some screens may not have a pointer available.

5. HOME SCREEN

- Home page provides access to App, Online Theater, Online Panorama video, Photos, Tools.
- Move your head to place the on-screen pointer atop the desired item. Click OK button on headset to enter into next page.



6. LOCAL APPS

- There are 3 ways to switch pages in Local Application: Move your head to place on-screen pointer on desired item and click OK; Click left/right button on VR headset; Place the on-screen pointer on left/right arrow at the bottom of page and click OK.
- There are 4 function keys below this page: left/right arrows used to switch icon; Trash key used to delete app; Click return key back to home page.
- Click return button on VR can also return to the home page.

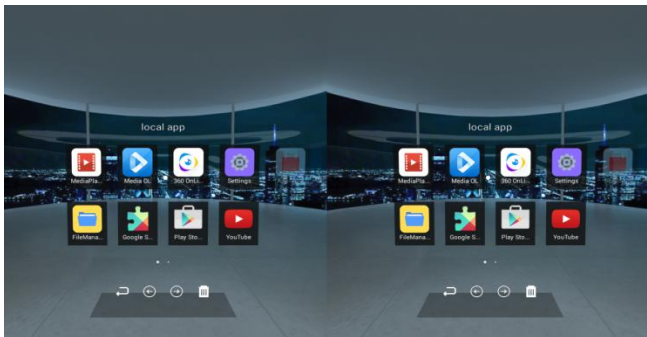

6.1 Media Player

- Move your head and click OK on aimed videos.
- Move your head downside and processing bar shows on screen. 5 functions on process bar: pause/play, loop, fast forward/backward, brightness adjustment, volume adjustment.
- Click return button on VR device back to previous page.



7. ONLINE THEATER

7.1 Main Screen Operation

- Move your head to place the on-screen pointer atop the desired item, press OK to enter into details introduction page. Then aim PLAY or BACK and press OK to play movie or exit to previous page.
- There are left/right arrows at the bottom of this page, aim and press OK button to shift pages.

- Press return button on VR headset to exit.



7.2 Play Screen Operation

- Move your head downside and processing bar shows on screen. 4 functions on process bar: pause/play, fast forward/backward, brightness adjustment, back to details introduction.
- Click return button on VR device back to previous page.



8. ONLINE PANORAMA VIDEO

8.1 Main Page Operation

- Move your head to place the on-screen pointer atop the desired item, press OK to confirm.

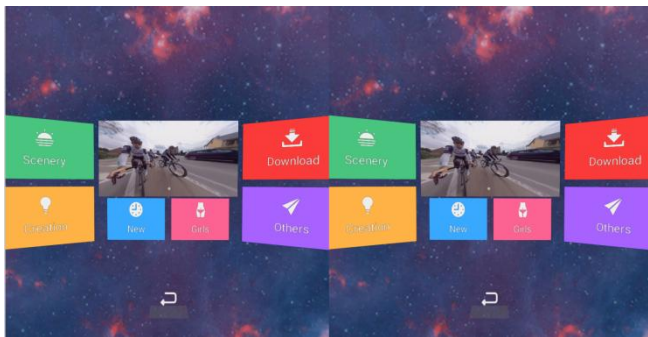

- There are left/right arrows at the bottom of this page, aim the arrows and press OK button to shift pages. Aims the return button back to previous page.

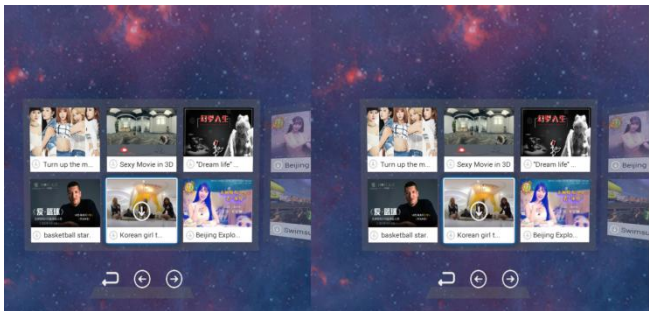

8.2 Playing Screen

- During playing, move your head down side, there will be a processing bar. Place on-screen pointer on desired options to pause/play, fast forward or backward, brightness adjustment, volume adjustment, exit.



9. PHOTOS

- There are two options under this menu: photo wall, 360 degrees photos. Move your head and aim the desired photo, press OK button



to check different photos

- In photo wall menu, aim the desired photo and press OK to see photo. Press RETURN button to exit.
- In panorama photo, Move your head to place on-screen pointer to desired photo and press OK to select. Press OK button to next photo. Press back button to exit.



10. TOOLS

- There are 4 options under this menu. Setting, Video Player, App Store and File Management.
- Move your head and place on-screen pointer on desired item and

click OK. Aim and click return arrow on this page to exit, or click return button on VR to exit.

- Setting and Files Management are controlled by direction keys on VR device.



10.1 Setting

Setting page include 5 options: Bluetooth, General, Wireless, System, and Account.

✓ Bluetooth

The device will search available Bluetooth device and list its name after enable Bluetooth function. Users can select desired device accordingly.

Notice: If connection failed, cancel previous setting and reconnect again.

✓ **General**

In this option, users can adjust the screen brightness, volume, select the language, change background theme, and change the time zone.

✓ **Wireless Network**

Scan the available wireless network, enter password to connect network. Users can also disconnect network and cancel the password.

✓ **System**

In this menu, users can see system update, restore factory settings, about the device

Regarding system update, users need to download a firmware (check with your seller) to a micro SD card, insert the card and find new version in LOCAL, select it and the device will then continue the software download process.

About the device: users can view the system version, hardware and software parameters.

✓ **Account**

10.2 Local Application (refer to 6 local App)

10.3 Store

Please goes to Tools --- App store to download VR apps and games with internet connected.

10.4 HDMI (refer to 3.6)

10.5 Files Manager

Three options included here: Videos, Pictures, APKs

- Videos: all videos, including on-line downloaded or copied from external devices are displayed here. Users can play or delete video files in this option.
- Pictures: all pictures in VR, including on-line downloaded or copied external devices are displayed here. Users can play or delete picture files in this option.
- APKs: all APKs, including on-line downloaded or copied from external devices are displayed here. Users can install or delete those APK in this option.