



# Premier™

A **WATTS®** Brand

## INSTALLATION, OPERATION AND MAINTENANCE MANUAL

### Warning

Please read carefully before proceeding with installation. Your failure to follow any attached instructions or operating parameters may lead to the product's failure.

Save manual for future reference

## Model: RO-PURE



System Tested and certified by WQA against NSF/ANSI Standard 58 for the reduction of the claims specified on the performance data sheet.

Refer to enclosed warranty for operating parameters to ensure proper use with your water supply.

Watts Premier  
Phone: 800-752-5582  
Manual: 199404

8716 W Ludlow Drive, Suite 1  
[www.premierH2o.com](http://www.premierH2o.com)

Peoria, AZ 85381  
Fax: 623-866-5666  
Manual Date: 07/20/2016

**Thank you for your purchase of a state of the art Premier Reverse Osmosis (RO) water treatment system.** Water quality concerns are becoming more of a focus for the public. You may have heard about contaminants in the drinking water such as Arsenic, Chromium, Cryptosporidium or Giardia. There may also be some local water issues such as high levels of Lead and Copper. This Premier water treatment system has been designed and tested to provide you with high quality drinking water for years to come. The following is a brief overview of the system.

**Your Reverse Osmosis System:**

Osmosis is the process of water passing through a semi permeable membrane in order to balance the concentration of contaminants on each side of the membrane. A semi permeable membrane is a barrier that will pass only certain particles like clean drinking water, but not other particles like arsenic and lead.

Reverse osmosis uses a semi permeable membrane; however, by applying pressure across the membrane, it concentrates contaminants (like a strainer) on one side of the membrane, producing crystal clear water on the other. This is why RO systems produce both clean drinking water and rinse water that is flushed from the system. This reverse osmosis system also utilizes carbon block filtration technology, and can therefore provide a higher quality drinking water than carbon filtration systems alone.

Your system is a four stage RO which is based upon separate treatment segments within the one complete water filtration system. These stages are as follows:

**Stage 1 – Sediment filter, recommended change 6 months.**

The first stage of your RO system is a five micron sediment filter that traps sediment and other particulate matter like dirt, silt and rust which affect the taste and appearance of your water.

**Stage 2 – Carbon filter, recommended change 6 months.**

The second stage contains a 5 micron carbon block filter. This helps ensure that chlorine and other materials that cause bad taste and odor are greatly reduced.

**Stage 3- Membrane, recommended change 2-5 years.**

Stage three is the heart of the reverse osmosis system, the 50GPD (Gallons Per Day) RO membrane. This semi permeable membrane will effectively remove TDS, Sodium and a wide range of contaminants such as Chromium, Arsenic, Copper, Lead as well as Cysts, such as Giardia and Cryptosporidium. Because the process of extracting this high quality drinking water takes time, your RO water treatment system is equipped with a storage tank.

**Stage 4- Carbon post filter, recommend change 12 months.**

The final stage is a high quality carbon filter. Drinking water enters this filter after the water storage tank and it is used as a final polishing filter.

**Note:** Filter & Membrane life may vary based upon local water conditions and/or use patterns.

**System Maintenance**

Just because you cannot taste it, does not mean that it is not there. Contaminants such as Lead, Chromium and Arsenic are undetectable to the taste. Additionally, over time if you do not replace the filter elements, other bad tastes and odors will be apparent in your drinking water.

It is important to change out your filters at the recommended intervals as indicated in this system manual. When replacing the filter elements, pay special attention to any cleaning instructions. Should you have any further questions please refer to our web site at [www.premierH2o.com](http://www.premierH2o.com) or call our customer service department at **1-800-752-5582**.

With proper installation and maintenance, this system will provide you with high quality water for years to come. All of Premier's water enhancement products are rigorously tested by independent laboratories for safety and reliability. If you have any questions or concerns, please contact our customer service department at 1-800-752-5582 (outside USA 480-675-7995) or refer to our on-line troubleshooting guide at [www.premierH2o.com](http://www.premierH2o.com).

**\*\* Before installation, please take a moment to fill out the warranty card on page 25.**

## Table of Contents

Operational Parameters.....	4
Contents of Reverse Osmosis System.....	4
<b>Installation &amp; Startup</b>	
Tools Recommended For Installation .....	4
Plumbing diagram and parts list.....	5
Drill a Hole for the Reverse Osmosis Faucet .....	6
How to use Quick Connect Fittings on Your RO System .....	6
Faucet Installation .....	7
Helpful Installation Tips for the Watts Top Mount Faucet.....	8
Adapt-a-Valve Installation .....	9
Drain Saddle Installation.....	10
Drain Saddle Tube Connection.....	10
Blue Tube Connection .....	11
Red Tube Connection.....	11
Green Tube Connection .....	12
Reverse Osmosis Module Mounting.....	12
Tank Ball Valve Installation .....	12
Blue Tube Connection (From The Storage Tank to Shut Off Valve) .....	12
Start up Instructions.....	13
<b>Maintenance &amp; Troubleshooting</b>	
Changing The Filter Cartridges .....	14
Membrane Replacement .....	14
Annual Sanitization .....	15
Check Air Pressure in the Tank .....	16
Procedure for Extended Non-Use (More than 2 months) .....	16
Troubleshooting .....	17
<b>Product Technical &amp; Warranty Information</b>	
Performance Data Sheet.....	18
Arsenic Fact Sheet .....	19
Service Record.....	21
Limited Warranty .....	22

# Operational Parameters

**Installation must comply with State and local plumbing regulations. Do not use with water that is micro biologically unsafe or of unknown quality without adequate disinfection before or after the system. System is intended to be installed using the cold water supply only.**

<b>Operating Temperatures:</b>	Maximum 100°F (37.8°C)	Minimum 40°F (4.4°C)
<b>Operating Pressure:</b>	Maximum 100 psi (7.0 kg/cm <sup>2</sup> )	Minimum 40 psi (2.80 kg/cm <sup>2</sup> )
<b>pH Parameters:</b>	Maximum 11	Minimum 2
<b>Iron:</b>	Maximum 0.2 ppm	
<b>TDS (Total Dissolved Solids)</b>	< 1800 ppm	
<b>Turbidity</b>	< 5 NTU	
<b>Hardness</b>	Maximum 10 Grains Per Gallon *	

**Hardness:** Recommended hardness not to exceed 10 grains per gallon, or 170 parts per million.

\* System will operate with hardness over 10 grains but the membrane life may be shortened.

Addition of a water softener may lengthen the membrane life.

**Water Pressure:** The operating water pressure in your home should be tested over a 24 hour period to attain the maximum pressure. If the incoming water pressure is above 100 psi then a water pressure regulator is required. A booster pump is needed for incoming water pressure under 40psi.

**Copper Tube:** Reverse Osmosis water should not be run through copper tube as the purity of the water will leach copper causing an undesired taste in water and pin holes may form in the tube.

## Contents of the Reverse Osmosis (RO) System

- 1 Tank
- 1 Module – (Filters Pre-Installed)
- 1 Parts Bag
- 1 Faucet Bag
- 1 Manual



*If any of the items are missing please contact Premier prior to installing.*

# INSTALLATION & STARTUP

## Tools Recommended For Installation

- √ 1 1/4" Diamond Tipped Hole Saw bit for faucet opening (Counter Tops/Porcelain & Stainless Sinks)
- √ 1 1/4" Adjustable Wrench
- √ 1/2" Open End Wrench
- √ 5/8" Open End Wrench
- √ Electric Drill
- √ 1/8" diamond tip bit, pilot hole
- √ 1/4" drain saddle hole
- √ Phillips bit for electric drill
- √ Needle Nose Pliers
- √ Adjustable Pliers
- √ Sharp Knife
- √ Phillips Screw Driver



# Plumbing Diagram and Parts List

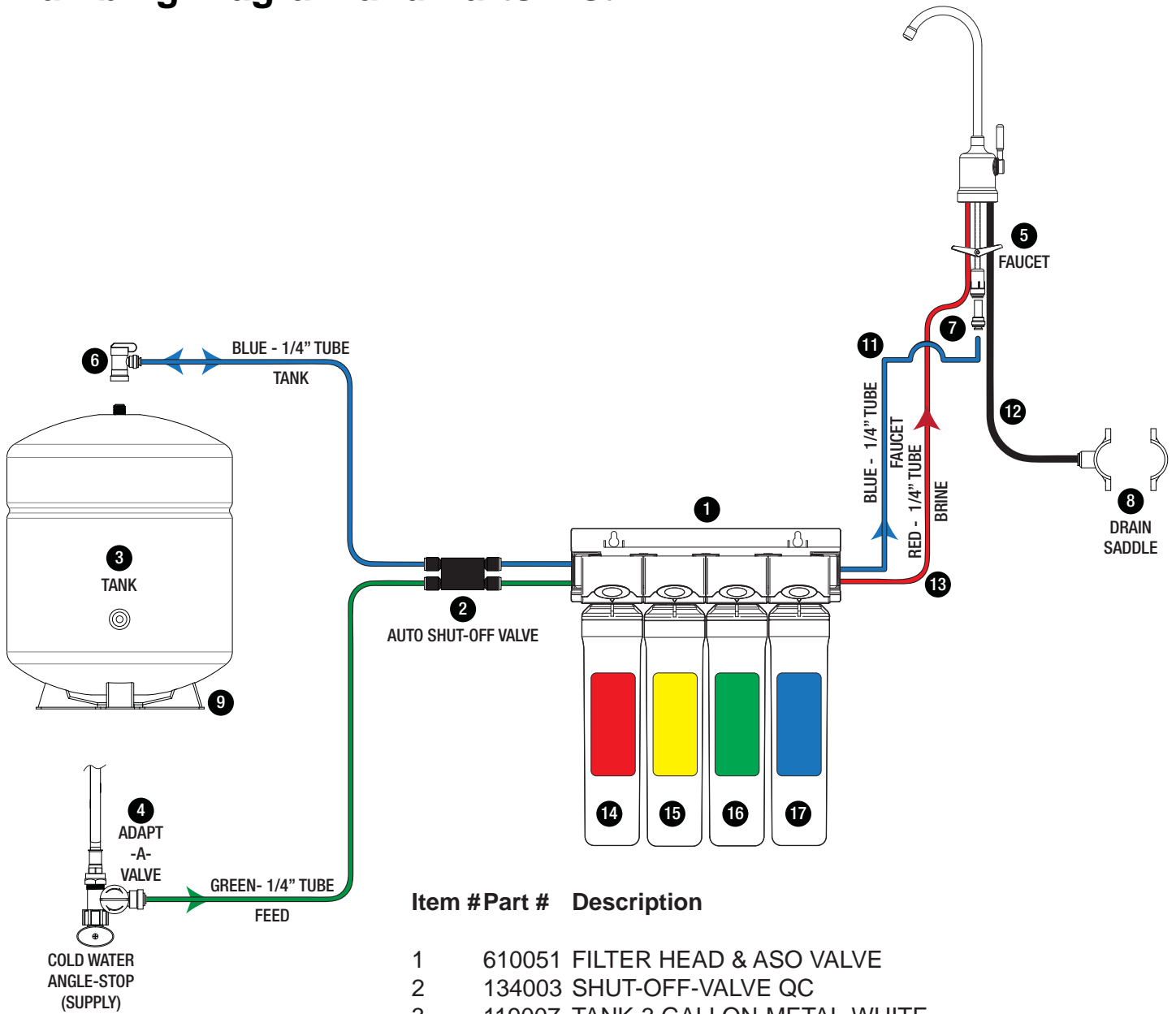

## Item # Part # Description

Item #	Part #	Description
1	610051	FILTER HEAD & ASO VALVE
2	134003	SHUT-OFF-VALVE QC
3	119007	TANK-3 GALLON-METAL-WHITE
4	560080	ADAPT-A-VALVE KIT
5	420063	FAUCET-AG-BN-MONITOR-NO TUBING
6	134018	TANK-VALVE-BALL-ELB-1/4QCX1/4F
7	228173	FITTING - 3/8" STEM X 1/4" QC ADAPTER
8	164056	DRAIN SADDLE 3/8" - KIT
9	119028	TANK STAND
10	142000	1/4" GREEN TUBING 90° - 4FT x 1
11	142001	1/4" BLUE TUBING 90° - 4FT x 2
12	400048	3/8" BLACK TUBING - 3FT x 1
13	142002	1/4" RED TUBING 90° - 4FT x 1
14	105311	SEDIMENT PRE-FILTER
15	105351	CARBON PRE-FILTER
16	105331	REVERSE OSMOSIS MEMBRANE 50GPD
17	105341	GAC CARBON POST FILTER

# Drill a Hole for the Reverse Osmosis Faucet

## Marble Counter-top

We recommend contacting a qualified contractor for drilling a hole in a marble counter-top.

## Counter Top / Porcelain & Stainless Steel Sink

**Note:** Most sinks are pre drilled with 1 1/4" diameter hole that you can use for your RO faucet. (If you are already using it for a sprayer or soap dispenser, see step 1)

**Porcelain sinks are extremely hard and can crack or chip easily. Use extreme caution when drilling. Watts accepts no responsibility for damage resulting from the installation of faucet. Diamond tip bit recommended.**

- Step 1 Determine desired location for the RO faucet on your sink and place a piece of masking tape over where the hole is to be drilled. Mark the center of the hole on the tape.
- Step 2 Using a variable speed drill set on the slowest speed, drill a 1/8" pilot hole through both porcelain and metal casing of sink at the marked center of the desired location. Use lubricating oil or liquid soap to keep the drill bit cool (If drill bit gets hot it may cause the porcelain to crack or chip).
- Step 3 Using a 1 1/4" diamond tip hole saw, proceed to drill the large hole. Keep drill speed on the slowest speed and use lubricating oil or liquid soap to keep the hole saw cool during cutting.
- Step 4 After drilling, remove all sharp edges and make sure the surroundings of the sink are cooled before mounting the faucet.

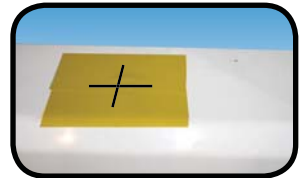

## How to use the Quick Connect Fittings

To make a connection, the tube is simply pushed into the fitting. The unique locking system holds the tube firmly in place without deforming it or restricting flow. Use the steps below in reference to any quick connect tube connections.

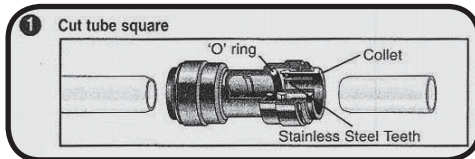

It is essential that the outside diameter be free of score marks and that burrs and sharp edges be removed before inserting into fitting.

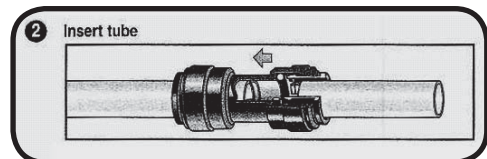

Fitting grips before it seals. Ensure tube is pushed into the tube stop.

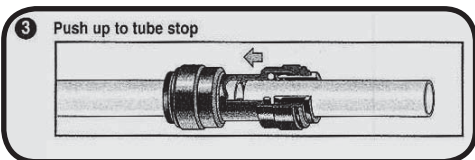

Push the tube into the fitting, to the tube stop. The collet (gripper) has stainless steel teeth which hold the tube firmly in position while the O-ring provides a permanent leak proof seal.

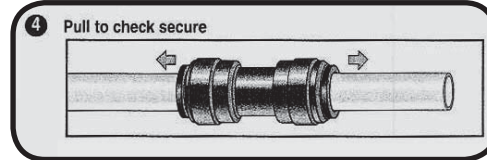

Pull on the tube to check that it is secure. It is a good practice to test the system prior to leaving site and /or before use.

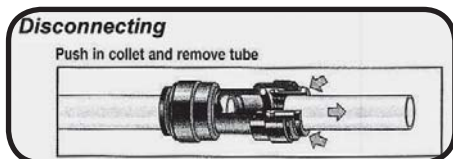

To disconnect, ensure the system is depressurized before removing the tube. Push in the collet squarely against face of fitting. With the collet held in this position, the tube can be removed. The fitting can then be reused.

# Premier Monitored (Top Mount) Faucet Installation

## A) Connect tubes to the RO faucet (Figure A)

This RO faucet is equipped with quick connect fittings for easy tube installation. To connect tubes, simply push them *firmly* into their corresponding fitting on the RO faucet until fully seated.

**In the parts bag, locate one 3/8" Stem x 1/4" Quick connect fitting adapter, one 1/4" red tube, one 1/4" blue tube and one 3/8" black tube.**

1. Insert the 3/8" Stem adapter into the 3/8" fitting located on the end of the toggle bolt assembly.
2. Connect 1/4" **BLUE** tube. (1/4" Fitting Adapter on Toggle Bolt)  
**The BLUE tubing has one BENT end and one STRAIGHT end. Insert the STRAIGHT end firmly into the faucet fitting.**
3. Connect 3/8" **BLACK** tube. (3/8" Fitting on base of faucet)  
**Insert one open end firmly into the faucet fitting.**
4. Connect 1/4" **RED** tube. (1/4" Fitting on base of faucet)  
**The RED tubing has one BENT end and one STRAIGHT end. Insert the STRAIGHT end firmly into the faucet fitting.**

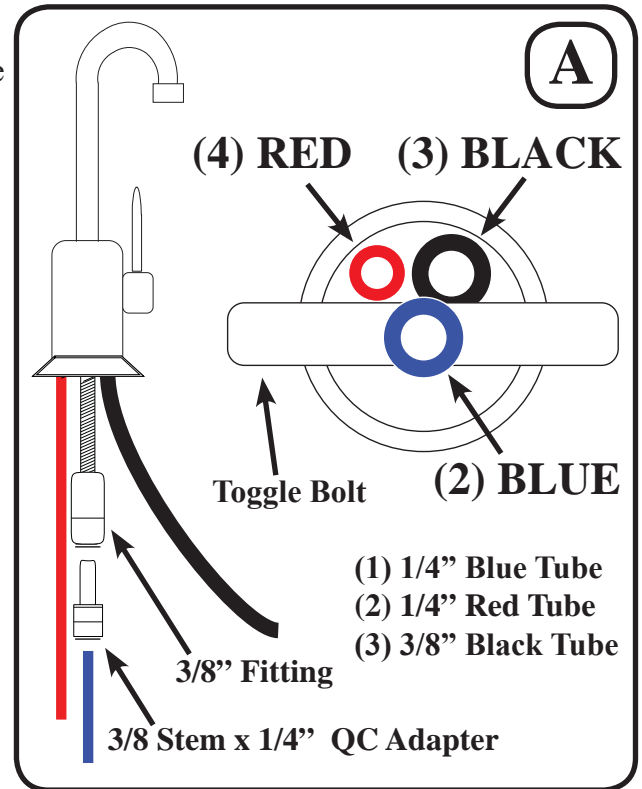

## B) Mount the RO faucet (Figure B)

A 1.0" - 1.25" Mounting hole is required for faucet installation.

5. Feed the toggle bolt and tubes through the mounting hole in the sink. Test fit faucet placement.
6. Peel the white backing paper off the seal on the bottom of the faucet base and press firmly over the mounting location.
7. Insert your Phillips head screwdriver through the spout hole of the RO faucet and torque the toggle bolt until the faucet is secure.  
**Do not overtighten!**

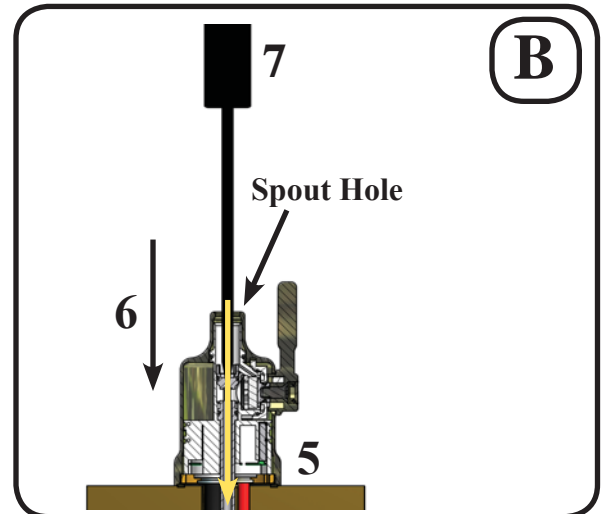

## C) Pull Battery Tab and Install Spout (Figure C)

8. Insert spout into the faucet base until fully seated.
9. Pull the Battery Safety Tab out to activate faucet monitor.  
Make sure that the clear drawer is firmly seated in the faucet base. The monitor will flash briefly once activated.

### **CAUTION!**

**"This product contains a button cell battery. If swallowed, it could cause severe injury or death in just 2 hours. Seek medical attention immediately."**

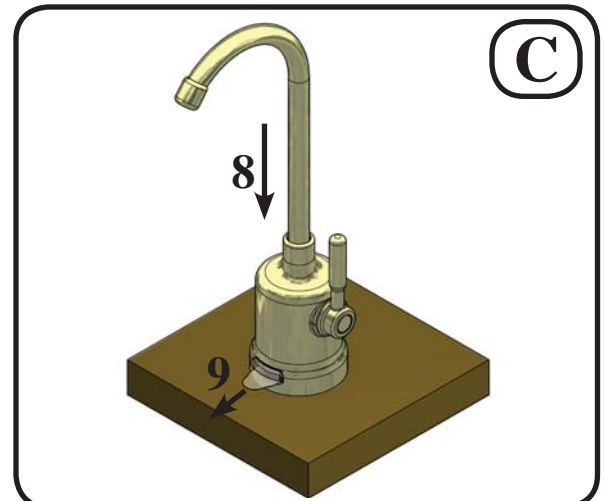

## Helpful Installation Tips for the Watts Top Mount Faucet

During shipping/handling the toggle bolt on your new faucet may push up out of position. Prior to the install, hold the faucet as shown in the picture and pull down on the wing nut. This will ensure that the O-rings are in their proper position and that your faucet will have a good seal.



Disassembling your faucet is never recommended as this could void your warranty. If it is necessary to remove the fitting at the end of the toggle bolt you must follow the following procedure for re-assembly. Prior to re-connecting the fitting to the toggle bolt, you must insert the 3/8" blue tube into the fitting. There are small O-rings inside of the fitting that could be pushed out of position if the blue tube is not fully inserted first. Failure to do so may cause the faucet to leak.

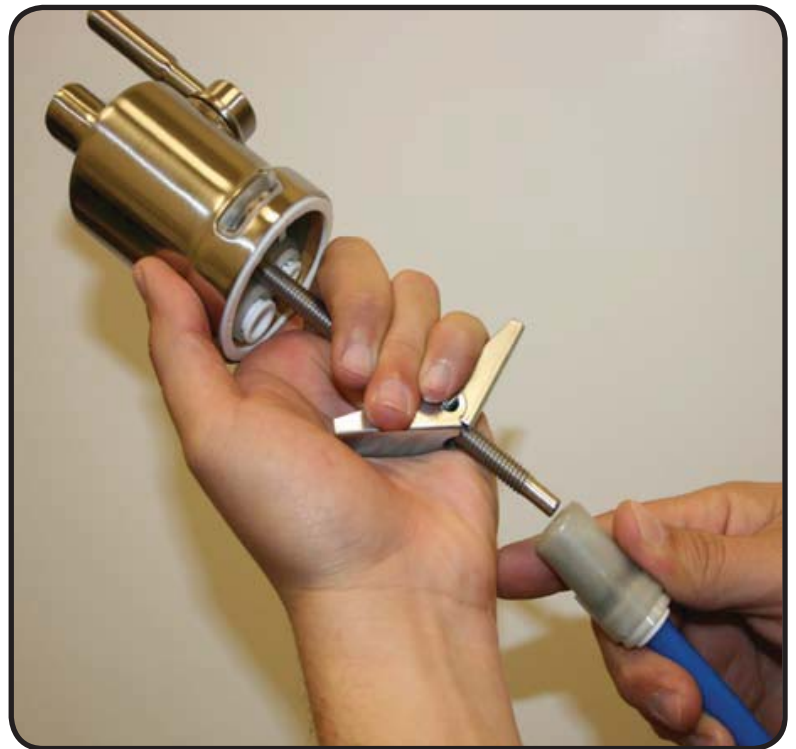

# Adapt-a-Valve Installation

**Caution:** Water supply line to the system must be from the cold water supply line only. Hot water will severely damage your system.

## Verify contents prior to installation:

- ( 1 ) - Plastic Adapt-a-Valve with black collet
- ( 1 ) - Brass Adapter no washer
- ( 1 ) - Brass Adapter with black washer
- ( 1 ) - White rubber washer



3/8" Configuration  
(With Brass Fittings)  
\* Insert White Washer



Hot Supply      Cold Supply



1/2" Configuration  
(Without Brass Fittings)

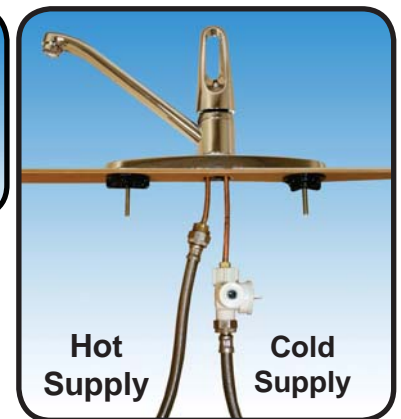

Hot Supply      Cold Supply

**WARNING:** Do not use Teflon tape with the Adapt-a-Valve.

Step 5 Turn off the cold water supply to the faucet by turning the angle stop valve completely off. Open cold water sink faucet to relieve pressure.

Step 6 Choosing the configuration that fits your plumbing, attach the adapt-a-valve as illustrated in the four photos above.

**TIPS:** Make sure that the black collet is installed in to the 1/4" opening on the Adapt-a-valve. Don't forget to install the white compression washer with the 3/8" configuration. Brass adapter (A) does not need to be tightened with a wrench, only finger tight.

# Drain Saddle Installation

Drain Saddle fits standard 1 ¼” – 1 ½” drain pipes

**Caution:** *If you have a garbage disposal, do not install the drain saddle near it. Installation of the drain saddle must be either above the garbage disposal, or if a second sink drain is available, install it above the cross bar on the second drain. Installation of the drain saddle near a garbage disposal may cause the drain line to plug. If no other installation of drain line is available, Premier offers drain line installation kit (part number 164020) that can be used with garbage disposals.*



Step 7 Gather the pieces of the drain saddle:

- |                         |                                   |
|-------------------------|-----------------------------------|
| 1 Black compression nut | 1 Semicircle bracket with opening |
| 2 Screws                | 1 Foam gasket                     |
| 2 Nuts for screws       | 1 Semicircle bracket              |

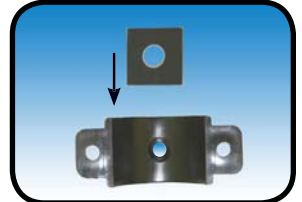

Step 8 The small square black foam gasket with a circle cut out of the middle must be applied to the inside of the drain saddle. Remove sticky tape backing and stick to the drain saddle as shown.



Step 9 The drain saddle must be mounted at least 1 ½” above the nut of the P-trap or cross bar from the garbage disposal to insure proper drainage. Assemble the drain saddle around the drain pipe at the best available location. Using Phillips screw driver tighten screws evenly and securely on both sides of the drain saddle. Keep the plastic compression nut off at this time.



**Caution:** *Do not over tighten the screws. It may crack the drain saddle.*

## Drill hole and Connect 3/8” Black Tube from Faucet to the Drain Saddle

### **IMPORTANT:**

*The black 3/8” drain tube must be as **SHORT** and **STRAIGHT** as possible to the drain saddle, making a downward slope from faucet to drain saddle to allow for proper drainage. This is a gravity fed line and if there is any bend or dip in the tube, the rinse water will not flow into the drain properly. Water may back up and come out the air gap hole in the back of the faucet.*

Step 10 With the drain saddle secured onto the drain pipe, using a 1/4” drill bit installed in your electric drill, insert the drill bit through the opening in the drain saddle and drill into the drain pipe.



**Caution:** *It is very important to keep the drill centered to prevent damage of the drain saddle while drilling.*

Step 11 Measure the 3/8” black tube from faucet to the drain saddle on the drain pipe and make a straight cut to the correct length.



Step 12 Slip black tube through black compression nut. Insert black tube into the opening in the drain saddle and hand tighten the black nut, and add 1/4 turn with a wrench.

## Rear View of RO-Pure System



### Blue Tube Connection (From FAUCET To The RO Module)

- Step 13 Locate the 1/4" BLUE tube attached to the RO faucet. Insert the open end of the tube with the 90° bend into the open 1/4" quick connect fitting on the back side of the RO-Pure Head behind the Post Filter head making sure the tube is pushed in all the way to the tube stop. **See Diagram Above**

### Red Tube Connection (From FAUCET To The RO Module)

- Step 14 Locate the 1/4" RED tube attached to the RO faucet. Insert the end of the red tube with the 90° bend into the open 1/4" quick connect fitting on the back side of the RO-Pure Head behind the Membrane head making sure the tube is pushed in all the way to the tube stop. **See Diagram Above**

**\* IMPORTANT:**

**The Flow Restrictor is installed inside of the red tube at the bent end. DO NOT REMOVE THE FLOW RESTRICTOR OR CUT THE RED TUBING AS IT WILL DAMAGE THE FLOW RESTRICTOR.**

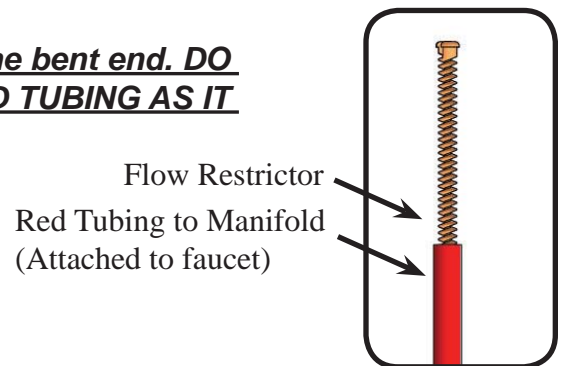
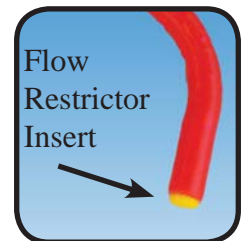

## Green Tube Connection

Step 15 Locate green tube attached to the RO Module. Insert the open end of the green 1/4" tube into the open 1/4" quick connect fitting on the plastic water feed valve making sure the tube is pushed in all the way to the tube stop.

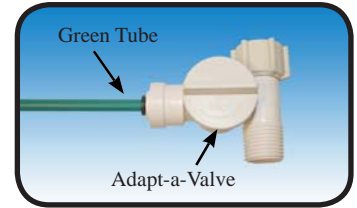

## Reverse Osmosis Module Mounting

Step 16 Determine best location for the RO module to be mounted to allow for future system maintenance. The parts bag has 2 self tapping screws. Using an electric drill with a Phillips bit, screw them into the cabinet wall 6" apart and 16" from the bottom of the cabinet.

**Note:** Do not cut any RO system tubes at this time



## Tank Ball Valve Installation - Part#: 134018

Step 17 Teflon tape must be applied in a clockwise direction. Wrap (7 to 12 turns) around the male pipe threads (MPT) on the stainless steel fitting on top of the tank.



Step 18 Thread the quick connect ball valve (supplied in the parts bag) onto the stainless steel connector on the tank.

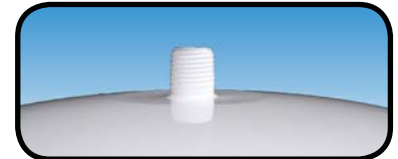

**Note:** Do not over-tighten plastic connections.



## Blue Tube Connection (From The Tank to Shut off Valve)

Step 19 Position tank in desired location. Stand it upright or lay it on its side (using the black plastic stand). Measure the blue tube (marked "TANK") from the RO module to the tank and cut it to length leaving a straight, square edge. Insert the tube into the quick connect fitting on the tank ball valve. Make sure the tube is pushed in all the way to the tube stop (see page 7 for quick connect fitting use directions).

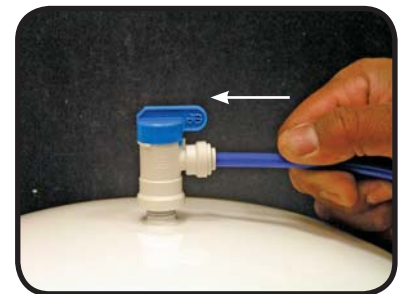

**Note:** Set the blue ball valve knob in-line with the blue tube, this is the "open" position.

# *Congratulations!*

You have completed the installation of your new Reverse Osmosis system.

Please Follow the Startup Instructions.

## Startup Instructions

- Step 1 Turn on the incoming cold water at the angle stop valve and the Adapt-a-Valve. Check the system for leaks and tighten any fittings as necessary. (Check frequently over the next 24 hours to ensure no leaks are present).



**Note:** *If you have connected your RO system to a refrigerator / ice maker, make sure the ice maker is off (do not allow water to flow to the ice maker) until flushing (Step 4) is complete and the tank has been allowed to fill completely. Connection from the RO to the ice maker system should have an in-line valve installed before the ice maker so it can easily be closed to prevent water flowing to the ice maker during start up and periodic maintenance. Your storage tank must be allowed to fill up fully in order for the ice maker system to work properly.*

- Step 2 Open the RO faucet and leave it open until water begins to trickle out (this may take a few minutes and the water will come out slowly).

- Step 3 Close the RO faucet allowing the storage tank to fill with water. It may take 3 to 6 hours to fill the tank completely depending on the production capability of the membrane, local water temperature and water pressure.

**Note:** *During the fill period you may hear water trickling which is a normal occurrence.*

- Step 4 After the storage tank has filled open the RO Faucet to flush the tank completely. You will know that the tank is empty when the flow rate from the RO faucet is down to a trickle. Repeat this step two more times. The fourth tank can be used for drinking.

**The flushing process should take about a day to complete.**

**Note:** *Flushing of the tank 3 times is only necessary during the initial startup and after replacing the membrane.*

# Changing The Filter Cartridges

Your RO module is equipped with valve heads which will automatically turn off the water supply to each filter when the filter is released, thus you do not need to turn off the incoming water supply at the Adapt-a-Valve. The RO faucet must be off when filters are replaced. To make the removal of the filter cartridges easier, the heads & cartridges may be swiveled up to 90 degrees as shown in the pictures below.

## 6 Month System Maintenance

**Replace:**      ✓ One sediment filter      (Red Label P/N: 105311)  
                     ✓ One carbon pre-filter      (Yellow Label P/N: 105351)

## Annual Maintenance - (Sanitization Recommended See PG.16)

**Replace:**      ✓ One sediment filter      (Red Label P/N: 105311)  
                     ✓ One carbon pre-filter      (Yellow Label P/N: 105351)  
                     ✓ One carbon post-filter      (Blue Label P/N: 105341)

**Tip:**      *This is a good time to check the air pressure in your storage tank. For instructions please see page 16.*

**Note:**      *Flush first tank full after completing the annual maintenance.*

**Step 1**      Place a towel under the RO module to catch any excess water that may drip out from the filters during the changeover.

**Step 2**      **To remove a filter cartridge:** Push & hold the button on the valve head above the filter. Pull cartridge downward (from the head) to remove. Release button and discard old filter.

**Step 3**      **To install a filter cartridge:** Remove the seal cap and insert the cartridge into the valve head until you hear an audible “click” (the button does not need to be pressed to install new filters).

**Note:**      *To reset the electronic monitor during replacement of filters, simply slide out the battery from the base of the faucet and reinsert.*



*This reverse osmosis system contains a replaceable component (the RO membrane) which is critical to the efficiency of the system. Replacement of this reverse osmosis membrane should be with one of identical specifications as defined by Premier to assure the same efficiency and contaminant reduction performance.*

## Membrane Replacement (2 - 5 Years)

**Replace:**      ✓ One Membrane      (50 GPD Green Label P/N: 105331)

Membranes have a life expectancy between 2 and 5 years, depending on the incoming water conditions and the amount the RO system is used. This reverse osmosis membrane is critical for effective reduction of total dissolved solids (TDS). The product water should be tested periodically to verify that the system is performing satisfactorily.

Normally, a membrane would be replaced during a semiannual or annual filter change. However, if at any time you notice a reduction in water production or an unpleasant taste in the reverse osmosis water, it could be time to replace the membrane. Premier recommends replacing the membrane when TDS reduction falls below 75%.

A water sample may be sent to Premier for a free diagnosis of your membranes performance. To send a water sample, use 2 clean containers and fill 1/2 cup of tap water in one container and 1/2 cup of RO water in 2nd container. Clearly label each sample. Send the samples to the address listed on the cover of this manual attention “Water Samples”. Premier will test the water and mail or call you with the results.

# Annual Sanitization

## NOTICE

**Do not change your post-carbon filter until the sanitization has been completed. The pre-filters and membrane can be changed before the sanitization**

Step 1: Turn off the water supply to your RO system at the adapt-a-valve and open the RO faucet to drain the storage tank.

## NOTICE

**If you have connected your RO system to a refrigerator/ice maker, make sure the connection has been turned off. Do not re-open the connection until the sanitization process is complete.**

Step 2: Locate the tube that runs between your filter module and the storage tank and disconnect at both ends.

Step 3: Drain any remaining water in the tube

Step 4: Hold both ends of the tube together with the ends pointed away from your face. Using a dosing syringe (see figure) slowly insert 1 teaspoon (5 mL) of common household bleach into the tube.

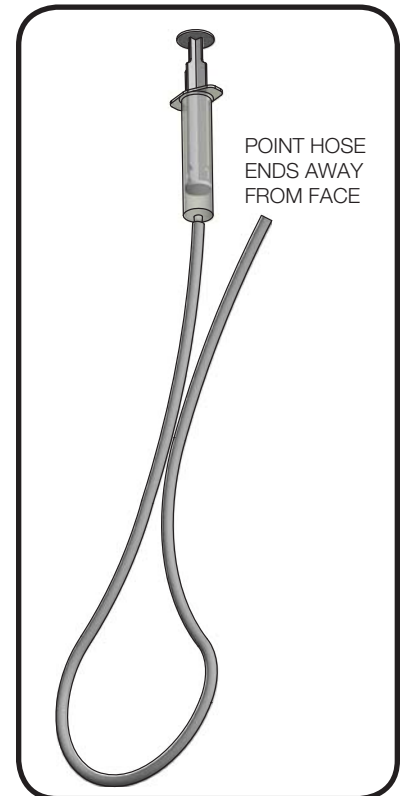

## WARNING

**Do not use needle syringe**

## DANGER



**IF BLEACH GETS IN EYES: Hold eye open and rinse slowly and gently with water for 15 - 20 minutes. Remove contact lenses if present, after the first 5 minutes, then continue rinsing eye. Call a poison control center or doctor for treatment advice.**

Step 5: While covering one end of the tube with your finger, insert the other into the tank. Then insert the open end into the filter module.

Step 6: Turn the incoming water back on and let the system fill for approximately 10 minutes

Step 7: Turn off the incoming water and let the system sit for 1 minute.

Step 8: Drain the system completely and then follow the startup procedure - filling then draining two full tanks of water.

Step 9: Replace the post-carbon filter once complete.

# Check Air Pressure in the Tank

**NOTICE** Check air pressure only when tank is empty of water!

Check air pressure in the storage tank when you notice a decrease in available water from the RO system. Air can be added with a bicycle pump using the schrader valve that is located on the lower side of the tank behind the blue plastic cap.

Step 1: Turn off the incoming water supply to the RO.

Step 2: Open the RO Faucet and allow water to drain from the tank until it is completely empty.

**TIP:** When water from the RO faucet slows to a trickle, with the faucet still in the open position, you may add air to the tank to purge any left over water, this will ensure that the tank is completely empty.



Step 3: Once all water in the tank is purged, check air pressure using an air pressure gauge, it should read between 5 - 7 PSI. (Digital air pressure gauge is recommended)

Step 4: Follow startup procedure on page 12.

## Procedure for Extended Non-Use (More than 2 months)

Turn off the water supply to your RO system at the adapt-a-valve and open the RO faucet to drain the storage tank. Once the storage tank is empty, remove all filter cartridges (order not important), place them into a sealed plastic bag and store in your refrigerator.

**NOTICE** DO NOT FREEZE

## To Restart System:

Step 1: Reinstall all filters on to the RO unit. Filters are color coded to match the filter heads they snap in to. Refer to page 13 step three for cartridge installation procedure.

Step 2: Turn on water supply to the system at the Adapt-a-Valve. (Check frequently over the next 24 hours to ensure no leaks are present).

**NOTICE** If you have connected your RO system to a refrigerator / ice maker, make sure the ice maker is off (do not allow water to flow to the ice maker) until the tank has been allowed to completely fill.

Step 3: Open the RO faucet and leave it open until water begins to trickle out (it will come out slowly).

Step 4: Close the RO faucet allowing the storage tank to fill with water. It may take 3 to 6 hours to fill the tank completely depending on the production capability of the membrane, local water temperature and water pressure.

Step 5: After the Tank has filled, open the RO Faucet to flush the tank completely. You will know that the tank is empty when the flow rate from the RO faucet is down to a trickle. The second tank can be used for drinking.

# TROUBLE SHOOTING

Problem	Cause	Solution
1. Low/Slow Production	<p>Low Water Pressure</p> <p>Crimps in tubing Clogged pre-filters Fouled membrane</p>	<p>Assure a minimum of 40 psi incoming water pressure. Premier sells a booster pump if home water pressure is low. Make sure water supply is turned on and feed water valve is all the way open.</p> <p>Check tubing and straighten or replace as necessary. Replace pre-filters. Replace membrane.</p>
2. Milky colored Water	Air in system	Air in the system is a normal occurrence with initial start up of the RO system. This milky look will disappear during normal use within 1-2 weeks. If condition reoccurs after filter change, drain tank 1 to 2 times.
3. Water constantly running, unit will not shut off	<p>Low water pressure</p> <p>Crimp in supply tube High water pressure</p> <p>High pressure in Tank</p> <p>Low Pressure in Tank</p>	<p>See #1 Above</p> <p>Check tubing and straighten or repair as necessary. Check incoming water pressure to make sure it does not exceed 80 psi. A pressure relief valve may be necessary.</p> <p>Empty storage tank of water. Set tank air pressure between 5-7 psi. See previous page.</p> <p>Use a Digital Air Gauge for best results. The empty tank pressure should be 5-7 psi. See page 16.</p>
4. Water from faucet vent hole or noise from drain.	<p>Crimp or restriction in drain line</p> <p>Drain tube clogged</p>	<p>Check tubing and straighten or repair as necessary. Straighten all drain lines. Clear blockage. Cut off any Excess tubing</p> <p>Caused from dishwasher or garbage disposal. Disconnect the 3/8" black line at the drain, clean the 3/8" black line out with a wire, then reconnect. Blowing air through the line will not always remove the clog.</p>
5. Small amount of water in storage tank	<p>System starting up</p> <p>Low water pressure Too much air in tank</p>	<p>Normally it takes 4-6 hours to fill tank. Note: low incoming water pressure and/or temperature can drastically reduce production rate.</p> <p>See #1 above.</p> <p>Tank air pressure should be 5-7 psi when empty of water. If below 5 psi add air or bleed if above 7 psi. Check only when tank is empty of water. See previous page.</p>
6. Low water flow from faucet	Check air pressure in tank	Use a Digital Air Gauge for best results. The empty tank pressure should be 5-7 psi. See page 16.

# TECHNICAL & WARRANTY INFORMATION

**Watts Premier**  
**8716 W Ludlow Drive Suite #1**  
**Peoria, AZ 85381**  
**RO-Pure**

**System conforms to NSF Standard 58 for specific claims.**

## GENERAL USE CONDITIONS:

1. System to be used with municipal or well water sources treated and tested on regular basis to insure bacteriological safe quality. DO NOT use with water that is microbiologically unsafe or unknown quality without adequate disinfection before and after the system. Systems certified for cyst reduction may be used on disinfected water that may contain filterable cysts.
2. This system is acceptable for treatment of influent concentrations of no more than 27 mg/L nitrate and 3 mg/L nitrite in combination measured as N and is certified for nitrite/nitrate reduction only for water supplies with a pressure of 280 kPa (40 psig) or greater. If your water supply is under 40 psi Premier recommends the use of a RO booster pump for proper operation.
3. Operating Temperature: Maximum: 100°F (40.5°C) Minimum: 40° (4.4°)
4. Operating Water Pressure: Maximum: 85 psi (6.0kg/cm2) Minimum: 40 psi (2.8kg/cm2)
5. pH: 2 to 11
6. Maximum Iron present in incoming water supply must be less than 0.2 ppm.
7. Hardness of more than 10 grains per gallon (170 ppm) may reduce RO membrane life expectancy.
8. Recommend TDS (Total Dissolved Solids) not to exceed 1800 ppm.



## RECOMMENDED REPLACEMENT PARTS AND CHANGE INTERVALS:

Note: Depending on incoming feed water conditions replacement time frame may vary.

Description		Change time Frame
Sediment Pre-filter:	#105311	6 Months
Carbon Pre-filter:	#105351	6 Months
Post Carbon filter	#105341	12 Months
50 GPD R.O. Membrane:	#105331	2 to 5 years

This system has been tested according to NSF/ANSI 58 for reduction of the substances listed below. The concentration of the indicated substances in water entering the system was reduced to a concentration less than or equal to the permissible limit for water leaving the system as specified in NSF/ANSI 58. This system has been tested for the treatment of water containing pentavalent arsenic (also known as As (V), As (+5), or arsenate) at concentrations of 0.30 mg/L or less. This system reduces pentavalent arsenic, but may not remove other forms of arsenic. This system is to be used on water supplies containing a detectable free chlorine residual at the system inlet or on water supplies that have been demonstrated to contain only pentavalent arsenic. Treatment with chloramine (combined chlorine) is not sufficient to ensure complete conversion of trivalent arsenic to pentavalent arsenic. Please see the Arsenic Facts section of the Performance Data Sheet for further information.

	Avg. In. (mg/L)	Avg. Eff. (mg/L)	% Reduction	pH	Pressure	Max Eff. mg/L	Inf. challenge concentration mg/L	Max Allowable concentration mg/L
Arsenic (Pentavalent)	.310	0.001	99.6%	7.24	50psi	0.002	0.30±10%	0.010 mg/L
Barium Reduction	9.2	0.08	99.0%	7.64	50psi	0.12	10.0±10%	2.0
Cadmium Reduction	0.031	0.0004	98.0%	7.49	50psi	0.0008	0.03±10%	0005
Chromium (Hexavalent)	0.30	0.002	99.0%	7.24	50psi	0.004	0.03±10%	0.1
Chromium (Trivalent)	0.30	0.001	99.0%	7.64	50psi	0.002	0.03±10%	0.1
Copper Reduction	3.2	0.02	99.0%	7.40	50psi	0.04	3.0±10%	1.3
Cysts	92,000#/ml	3 #/ml	99.99%	7.44	50psi	18	minimum 50,000/mL	N/A
Fluoride Reduction	8.7	0.19	97.0%	7.24	50psi	0.3	8.0±10%	1.5
Lead Reduction	0.15	0.002	98.8%	7.39	50psi	0.005	0.15±10%	0.0107
Perchlorate	130	2.8	97.9%					
Radium 226/228	25pCi/L	5pCi/L	80.0%	7.24	50psi	5pCi/L	25pCiL±10%	5pCiL
Selenium	94.85	<0.2	97.0%	7.24	50psi	<0.2	0.10±10%	0.05
TDS	770	35	95.0%	7.28	50psi	26.0	750±40mg/L	187
Turbidity	11.3	0.1	99.0%	7.43	50psi	0-1	11±1mg/L	0.5NTU

Recovery - 22%

Daily Production Rate - 20.5 GPD

Efficiency - 10.5%

Depending on water chemistry, water temperature, and water pressure Premier's R.O. Systems production and performance will vary. Efficiency rating means the percentage of the influent water to the system that is available to the user as reverse osmosis treated water under operating conditions that approximate typical daily usage. Recovery rating means the percentage of the influent water to the membrane portion of the system that is available to the user as reverse osmosis treated water when the system is operated without a storage tank or when the storage tank is bypassed. There is an average of 4 gallons of reject water for every 1 gallon of product water produced.

REFER TO OWNER'S INSTALLATION/SERVICE MANUAL FOR FURTHER MAINTENANCE REQUIREMENTS AND WARRANTY INFORMATION.

Phone: (480) 675-7995

Fax: (623) 866-5666

www.PremierH2o.com

## Arsenic Fact Sheet

Arsenic (As) is a naturally occurring contaminant found in many ground waters. Arsenic in water has no color, taste or odor. It must be measured by an arsenic test kit or lab test.

Public water utilities must have their water tested for arsenic. You can obtain the results from your water utility contained within your consumer confidence report. If you have your own well, you will need to have the water evaluated. The local health department or the state environmental health agency can provide a list of test kits or certified labs.

There are two forms of arsenic: pentavalent arsenic (also called As (V), As (+5)) and trivalent arsenic (also called As (III), As (+3)). In well water, arsenic may be pentavalent, trivalent, or a combination of both. Although both forms of arsenic are potentially hazardous to your health, trivalent arsenic is considered more harmful than pentavalent arsenic.

RO systems are very effective at removing pentavalent arsenic. A free chlorine residual will rapidly convert trivalent arsenic to pentavalent arsenic. Other water treatment chemicals such as ozone and potassium permanganate will also change trivalent arsenic to pentavalent arsenic. A combined chlorine residual (also called chloramine) where it does convert trivalent arsenic to pentavalent arsenic, may not convert all the trivalent arsenic in to pentavalent arsenic. If you get your water from a public water utility, contact the utility to find out if free chlorine or combined chlorine is used in the water system.

This Premier reverse osmosis system is designed to remove up to 98% of pentavalent arsenic. It will not convert trivalent arsenic to pentavalent arsenic. Under laboratory standard testing conditions, this system reduced 0.30 mg/L (ppm) pentavalent arsenic to under 0.010 mg/L (ppm) (the USEPA standard for drinking water). Actual performance of the system may vary depending on specific water quality conditions at the consumer's installation. In addition to the independent laboratory standard testing conditions Premier has conducted additional field testing on our reverse osmosis units to determine trivalent arsenic reduction capabilities. Based upon Premier field testing, it has been determined that the RO units are capable of reducing up to 67% of trivalent arsenic from the drinking water.

This reverse osmosis system contains a replaceable component critical to the efficiency of the system. Replacement of the reverse osmosis component should be with one of identical specifications, as defined by the manufacturer, to ensure the same efficiency and contaminant reduction performance. Specific component identification and ordering information can be found in the maintenance section of this manual, by phone at 1-800-752-5582 or online at [www.premierH2o.com](http://www.premierH2o.com)

This page intentionally left blank





A **WATTS®** Brand

## Limited Warranty

### WHAT YOUR WARRANTY COVERS:

If any part of your Reverse Osmosis System is defective in workmanship (excluding replaceable filters and membranes), return unit after obtaining a return authorization (see below), less tank, within 1 year of original retail purchase, Watts Premier will repair or, at Watts Premier's option, replace the system at no charge.

### HOW TO OBTAIN WARRANTY SERVICE:

For warranty service, call 1-800-752-5582 for documentation and a return authorization number. Once the return authorization number has been created, ship your Reverse Osmosis unit (less tank) to our factory, freight and insurance prepaid, with proof of date of original purchase. Include a note stating the problem experienced and include your name, address and your return authorization number. No returns will be accepted without the proper return authorization number. Watts Premier will repair it, or replace it, and ship it back to you prepaid.

### WHAT THIS WARRANTY DOES NOT COVER:

This warranty does not cover defects resulting from improper installation, (contrary to Watts Premier's printed instructions), from abuse, misuse, misapplication, improper maintenance, neglect, alteration, accidents, casualties, fire, flood, freezing, environmental factors, water pressure spikes or other such acts of God.

This warranty will be void if defects occur due to failure to observe the following conditions:

1. The Reverse Osmosis System must be hooked up to a potable municipal or well cold water supply.
2. The hardness of the water should not exceed 10 grains per gallon, or 170 ppm.
3. Maximum incoming iron must be less than 0.2 ppm.
4. The pH of the water must not be lower than 2 or higher than 11.
5. The incoming water pressure must be between 40 and 85 pounds per square inch.
6. Incoming water to the RO cannot exceed 105 degrees F (40 degrees C.)
7. Incoming TDS/Total Dissolved Solids not to exceed 1800 ppm.
8. Do not use with water that is micro biologically unsafe or of unknown quality without adequate disinfection before or after the system.

This warranty does not cover any equipment that is relocated from the site of its original installation. This warranty does not cover any charges incurred due to professional installation. This warranty does not cover any equipment that is installed or used outside the United States of America and Canada.

### LIMITATIONS AND EXCLUSIONS:

WATTS PREMIER WILL NOT BE RESPONSIBLE FOR ANY IMPLIED WARRANTIES, INCLUDING THOSE OF MERCHANTABILITY AND FITNESS FOR A PARTICULAR PURPOSE. WATTS PREMIER WILL NOT BE RESPONSIBLE FOR ANY INCIDENTAL OR CONSEQUENTIAL DAMAGES, INCLUDING TRAVEL EXPENSE, TELEPHONE CHARGES, LOSS OF REVENUE, LOSS OF TIME, INCONVENIENCE, LOSS OF USE OF THE EQUIPMENT, AND DAMAGE CAUSED BY THIS EQUIPMENT AND ITS FAILURE TO FUNCTION PROPERLY. THIS WARRANTY SETS FORTH ALL OF WATTS PREMIER'S RESPONSIBILITIES REGARDING THIS EQUIPMENT.

### OTHER CONDITIONS:

If Watts Premier chooses to replace the equipment, may replace it with reconditioned equipment. Parts used in repairing or replacing the equipment will be warranted for 90 days from the date the equipment is returned to you or for the remainder of the original warranty period, whichever is longer. This warranty is not assignable or transferable.

### YOUR RIGHTS UNDER STATE LAW:

Some states do not allow limitations on how long an implied warranty lasts, and some states do not allow the exclusion or limitation of incidental or consequential damages, so the above limitations or exclusions may not apply. This warranty gives you specific legal rights, and you may have other legal rights which vary from state to state.

**WARNING:** This product contains chemicals known to the State of California to cause cancer and birth defects or other reproductive harm.

**For more information:** [www.watts.com/prop65](http://www.watts.com/prop65)