

USER MANUAL

Preparation

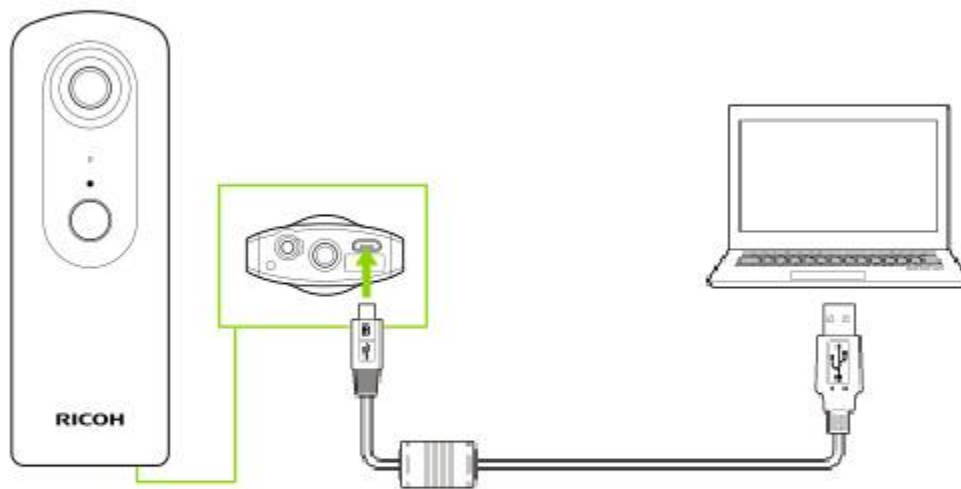

STEP1

Charging the camera

Connect the camera to your computer using the provided USB cable to charge it. The power lamp lights green during charging and goes out when the camera is fully recharged. (The lamp flashes in green when the remaining battery level is low.)

* The camera is charged in approx. 200 minutes (at 25°C (77°F)).

* When the remaining battery level is low, it may take a while for the camera to be recognized by the computer.



Drag & drop the spherical image

STEP2

Installing computer application "RICOH THETA"

1. Download the app suitable for your computer.

- [For Windows users \(start downloading\)](#)
- [For Mac users \(start downloading\)](#)

2. Double click the file downloaded and install it following the on-screen instructions. When a screen as shown in the diagram below appears, the installation is complete.

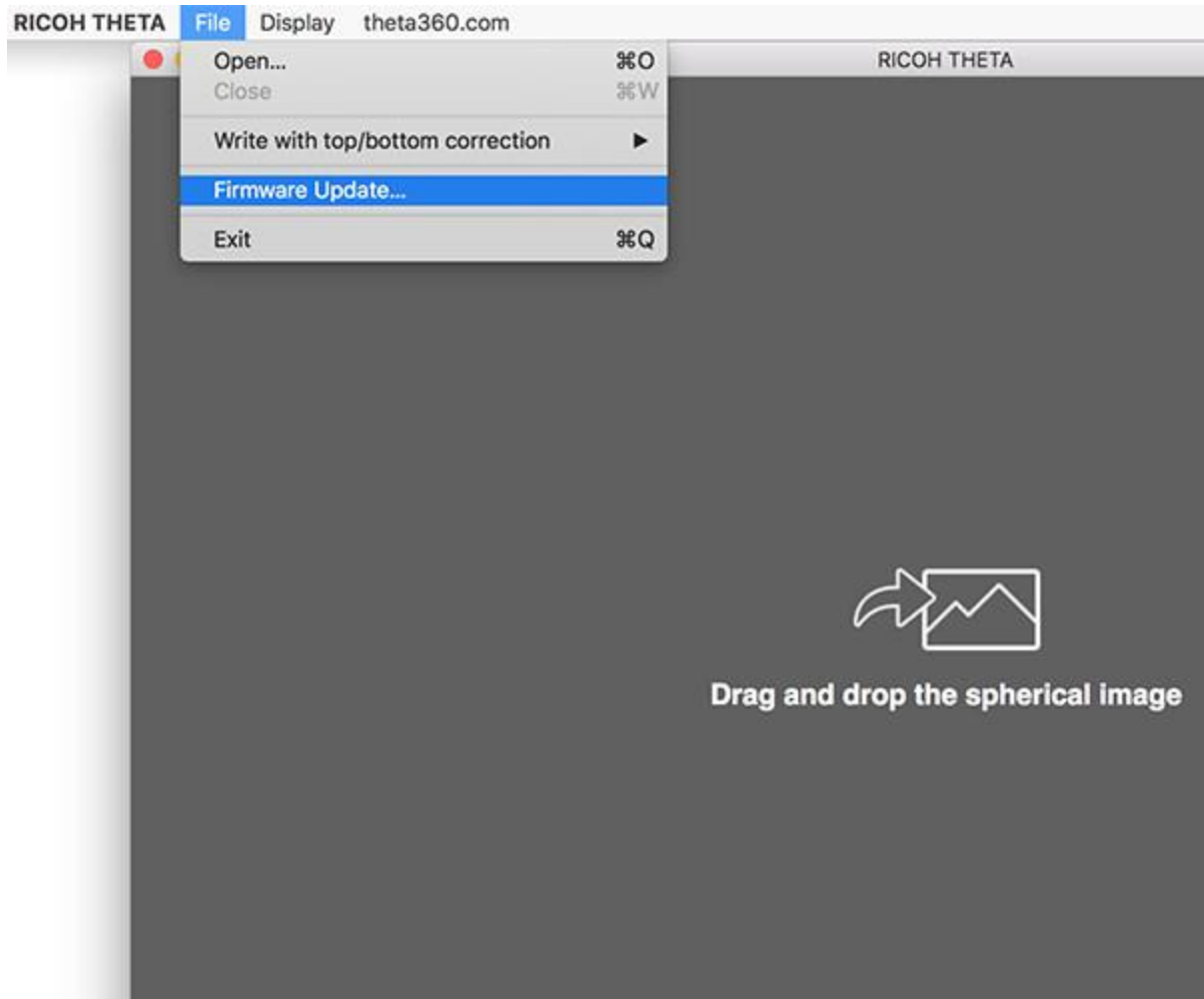

STEP3

Checking the camera firmware version

1. Start computer app "RICOH THETA".
 2. Select [File] → [Firmware Update] in the menu.
 3. Follow the instructions on the screen to connect the camera to your computer using the provided USB cable.
 4. Click [OK] and Check the firmware version.
 5. After checking the firmware version, click [OK] and disconnect the USB cable.
- * Internet connection of the computer is necessary.
- * If the firmware isn't the latest version, update it according to the message.

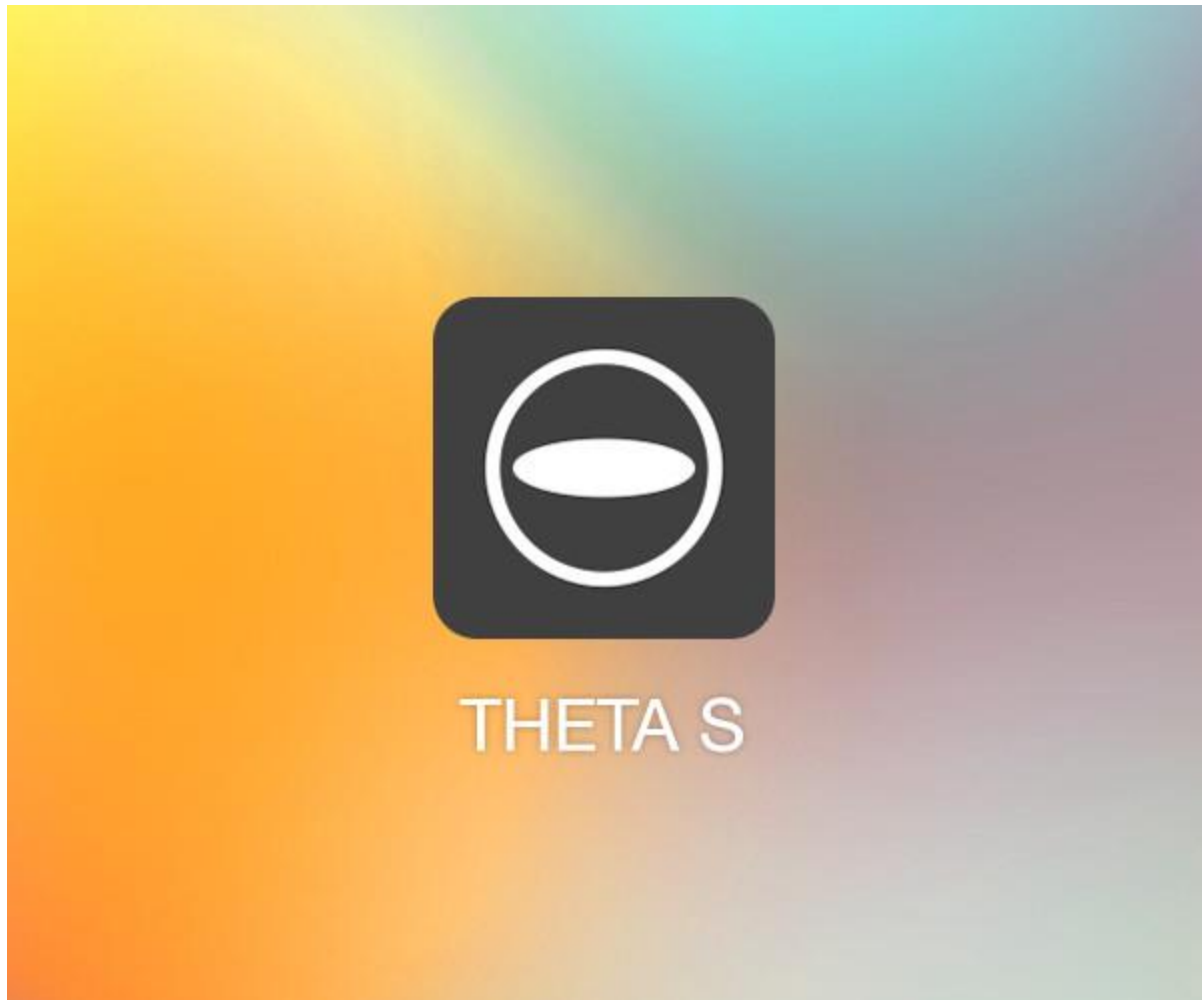

STEP4

Installing smartphone app "RICOH THETA S"

1. Access a site to download smartphone apps and search for "RICOH THETA S" Or install the app from the link below.

- [For iPhone users](#)
- [For Android users](#)

2. After installing, the icon as shown in the figure will be added.

Connecting/Setting

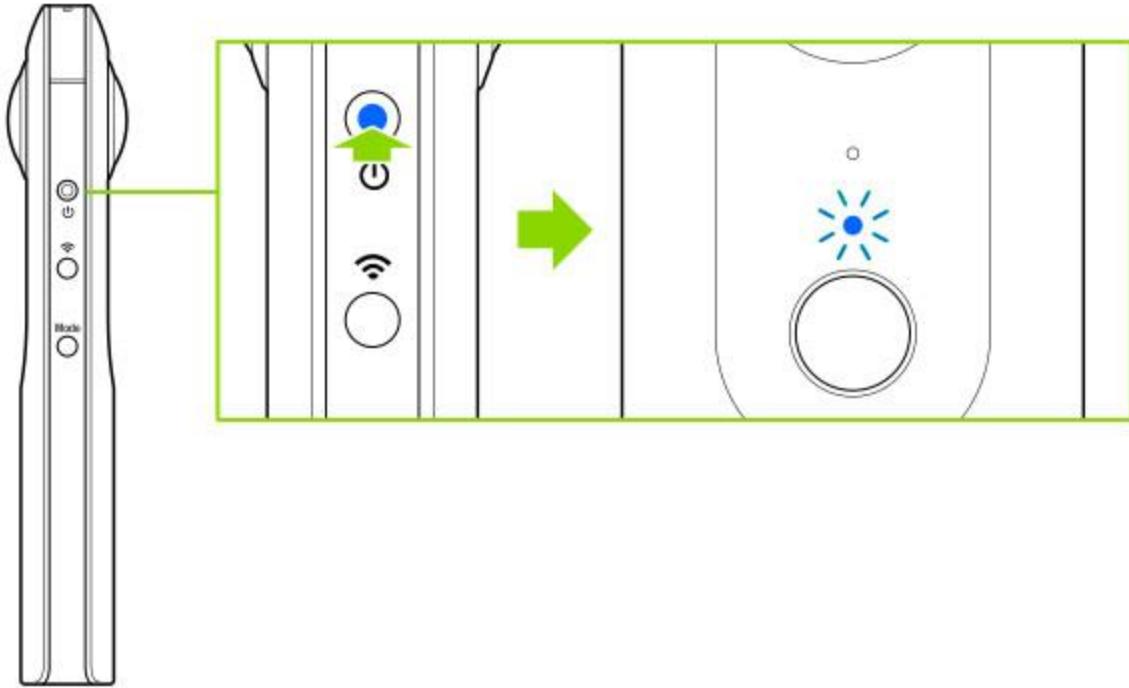

STEP1

Starting the camera

1. Press and hold the power button. Camera status lamp flashes in blue slowly during startup.
2. When the camera is ready for use, the Camera status lamp lights in blue.

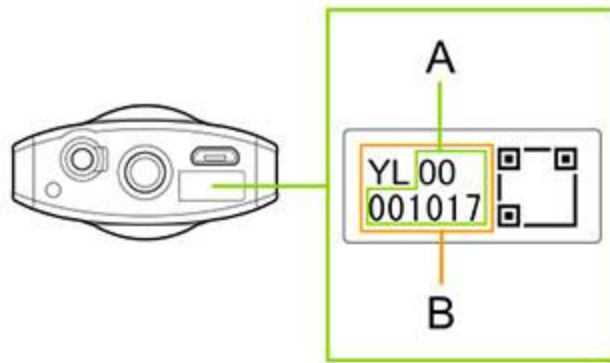
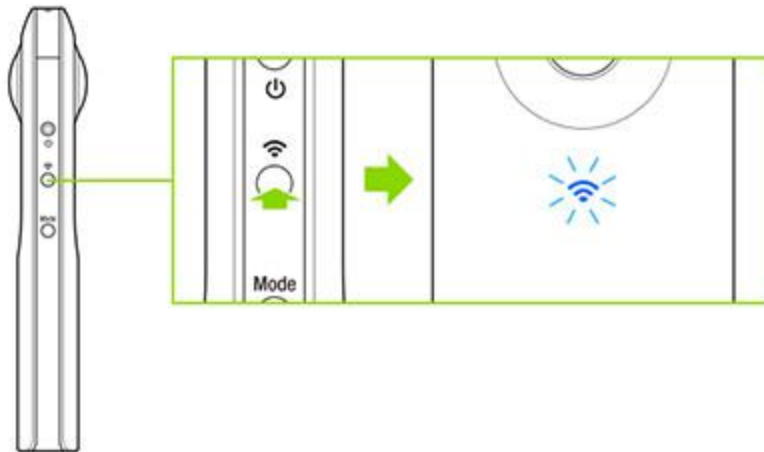

STEP2

Connecting the camera to a smartphone

1. Press the wireless button. The wireless lamp flashes in blue.
2. Display the Wi-Fi™ settings of the smartphone.
3. Check the serial number printed at the bottom of the camera.
 - * The serial number printed at the bottom of the camera is the same as the SSID and password.
4. Select "THETA*****.OSC" from the network list and enter the password.
 - * "*****" of SSID part is indicated by (B).
 - * The password is indicated by (A).
5. When the wireless lamp lights in blue, the camera is connected to the smartphone.

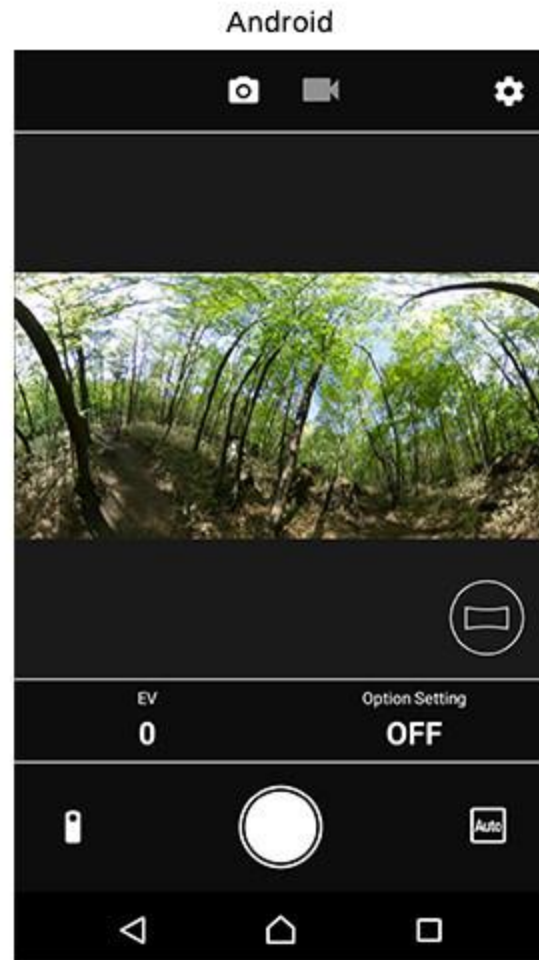
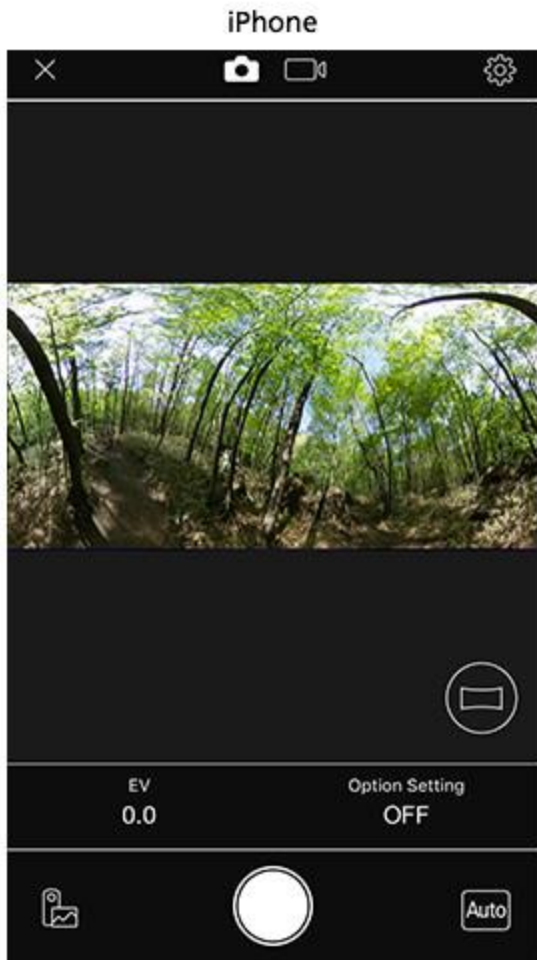

STEP3

Starting the smartphone app "RICOH THETA S"

1. Start "RICOH THETA S" app on the smartphone.
2. Tap "Cam images" on the bottom left of the screen.

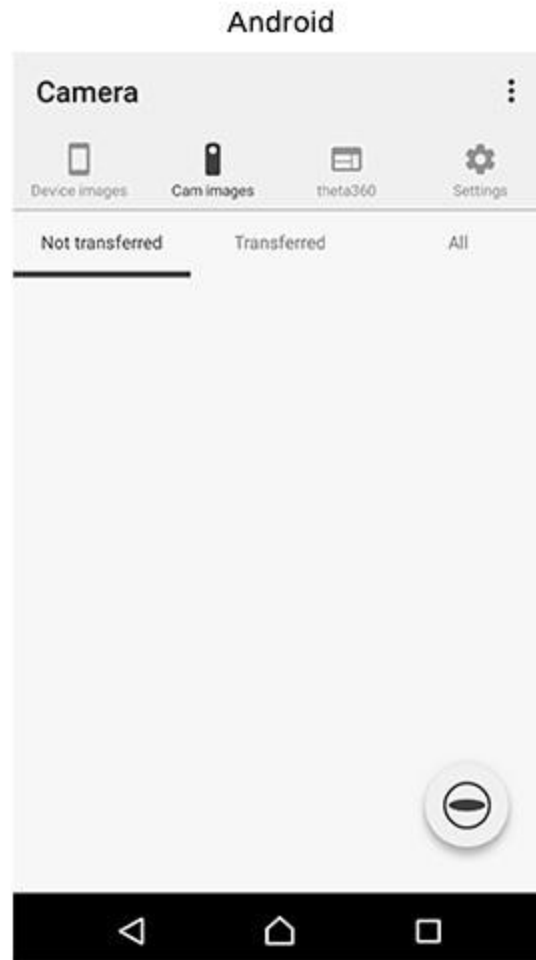
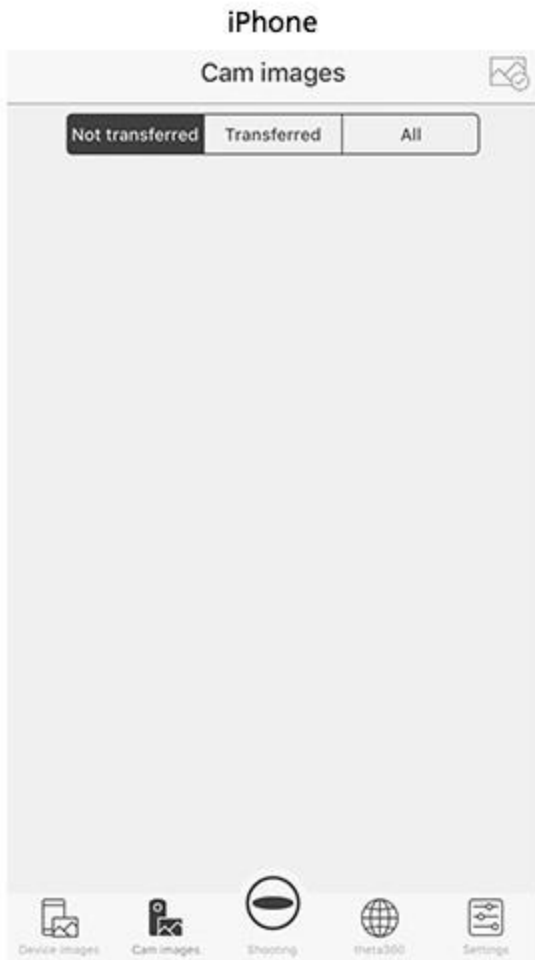

STEP4

Checking and changing the camera settings

Tap [Settings]. Change [Change Wi-Fi password]/[Sleep mode]/[Camera shutter volume]/[Transfer method].

* The date and time of the camera are synchronized with the smartphone when the camera is connected to the smartphone and "RICOH THETA S" of smartphone app is started.

* "Wi-Fi Password", "Sleep mode" and "Camera shutter volume" can be set only when the camera is connected to the smartphone.

Taken with the camera

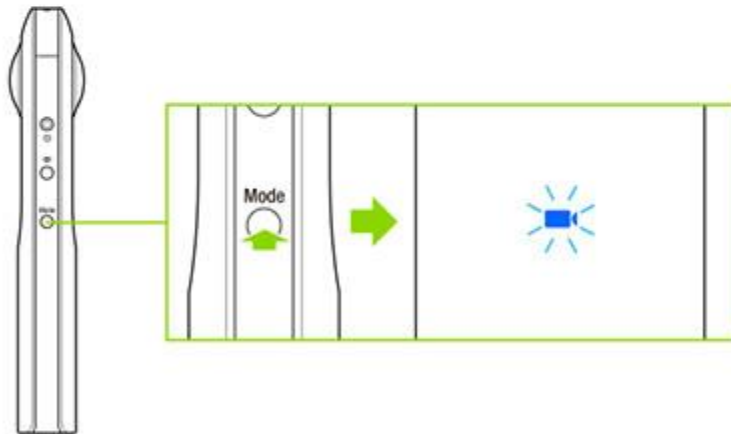
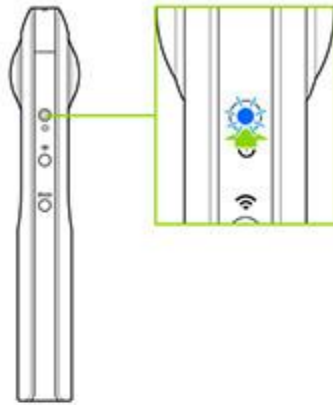

STEP1

Starting the camera

1. Press and hold the power button to start the camera.
2. Press the mode button to select the video mode.

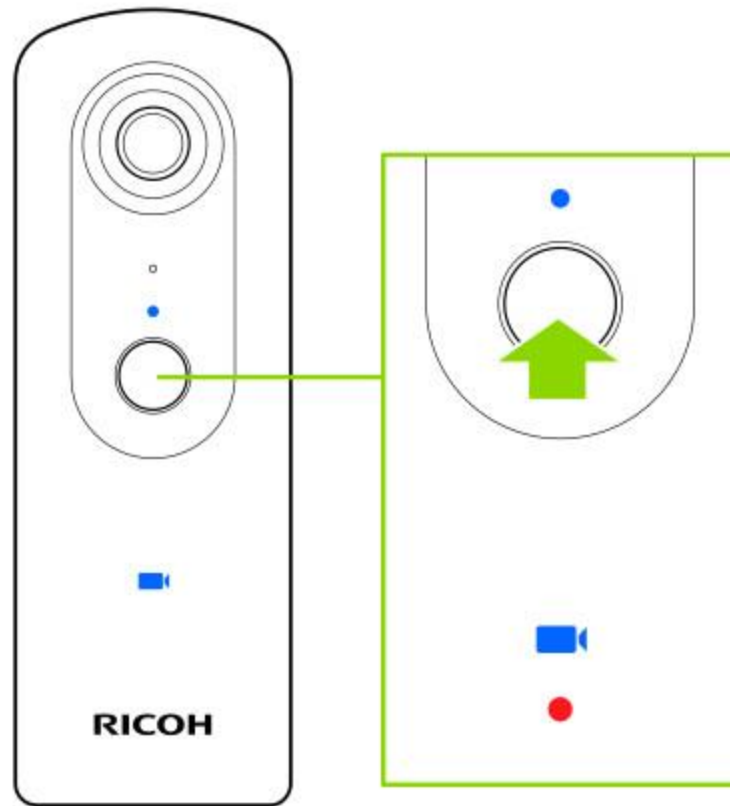

STEP2

Video shooting

Press the shutter button to start shooting. Press it again to stop shooting.

- [To learn more about how to view videos, click here.](#)
- [To learn more about how to share videos, click here.](#)

Taken with the smartphone

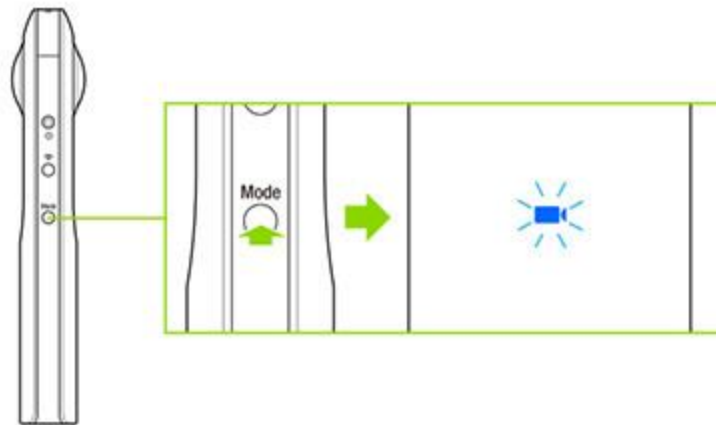
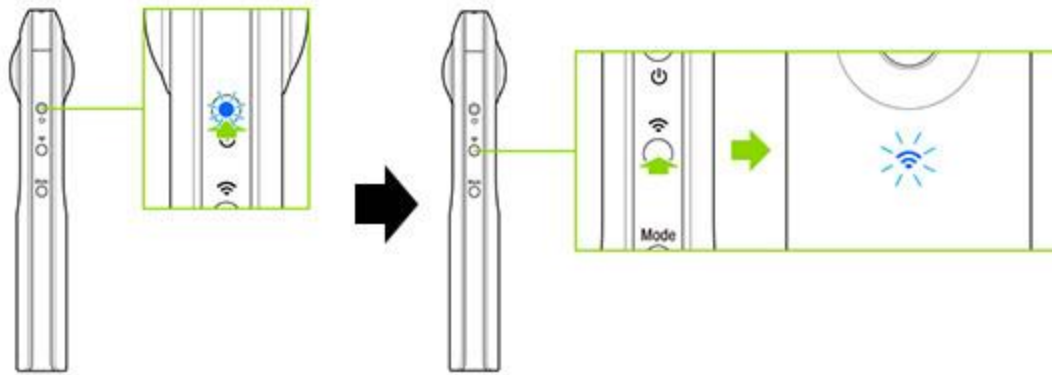

STEP1

Starting the camera

1. Press and hold the power button to start the camera.
2. Press the mode button to select the video mode.
3. Confirm that the wireless lamp is flashing. If it is off, press the wireless button.

- From the RICOH THETA S app remote shooting screen, you can switch shooting modes with the still image button/video button.

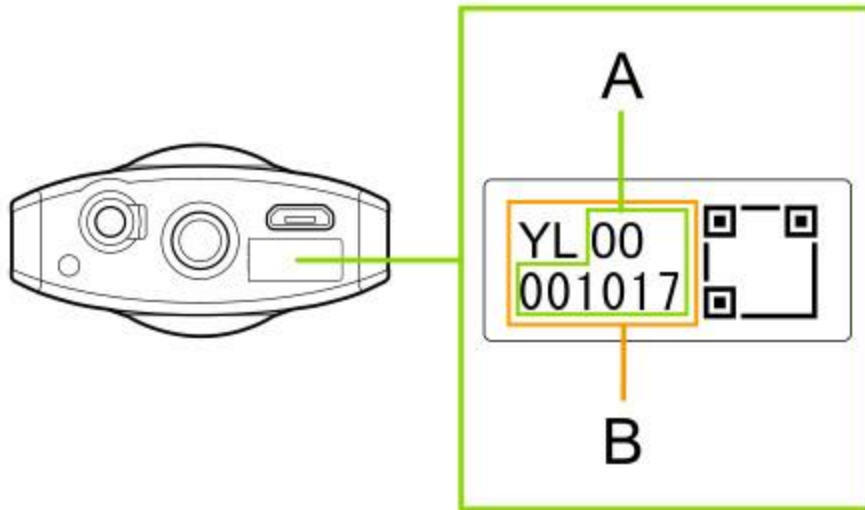

STEP2

Connecting the camera to a smartphone

1. Display the Wi-Fi™ settings of the smartphone.
2. Check the serial number printed at the bottom of the camera. * The serial number printed at the bottom of the camera is the same as the SSID and password.
3. Select "THETA*****.OSC" from the network list and enter the password. * "*****" of SSID part is indicated by (B).
- * The password is indicated by (A).
4. When the wireless lamp lights in blue, the camera is connected to the smartphone.

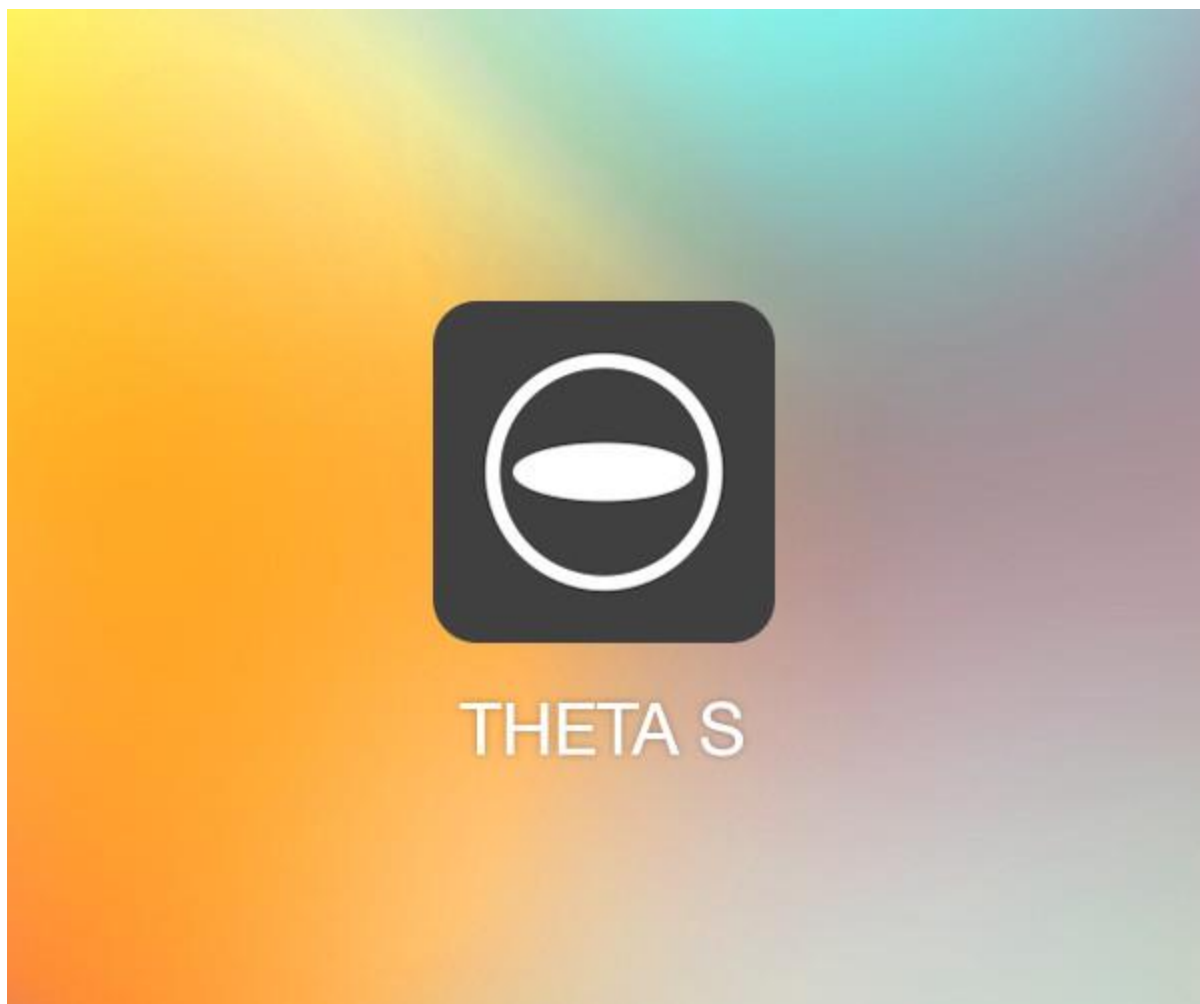

STEP3

Starting the smartphone app "RICOH THETA S"

Start "RICOH THETA S" app on the smartphone.

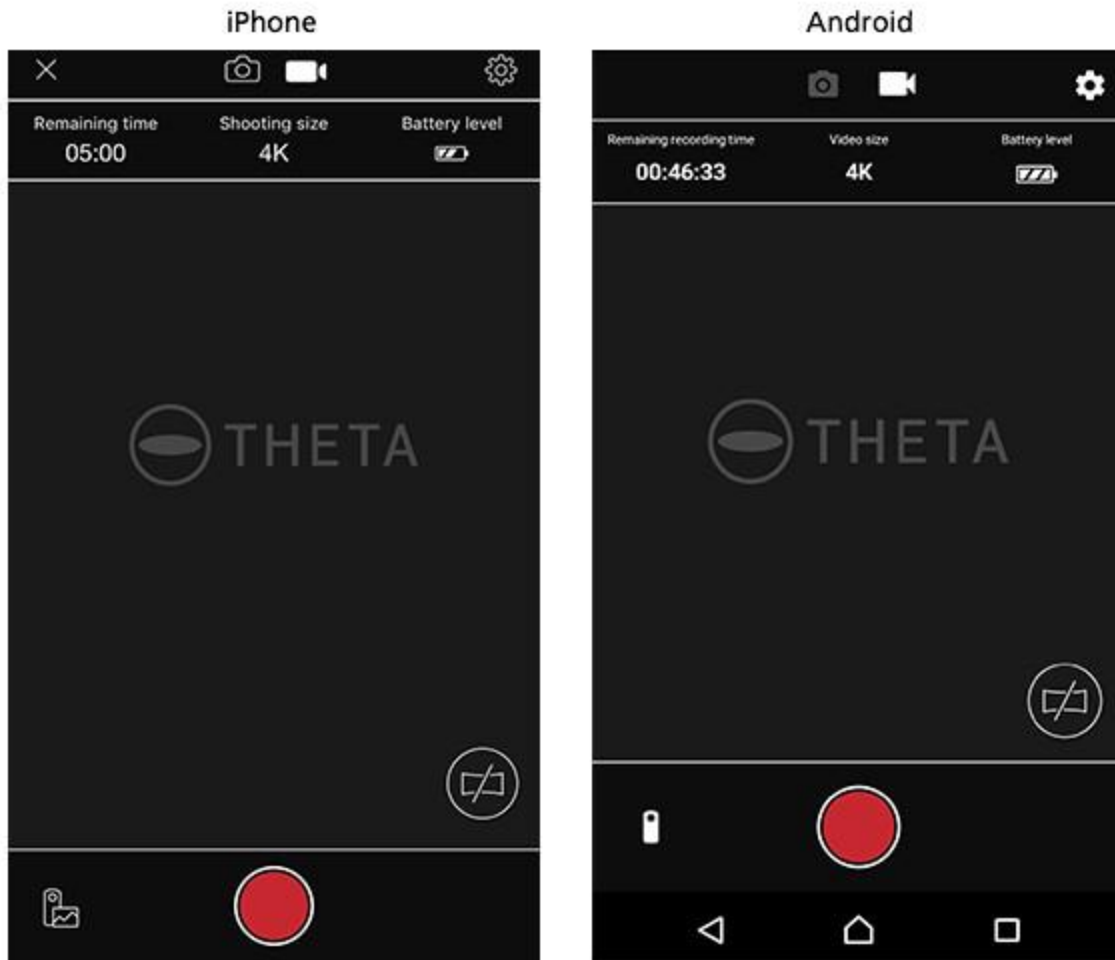

STEP4

Remote shooting

When you tap the [Shoot] button at the bottom center of the screen, shooting will start. Press it again to stop shooting.

- [To learn more about how to view videos, click here.](#)
- [To learn more about how to share videos, click here.](#)

Viewing video on your smartphone

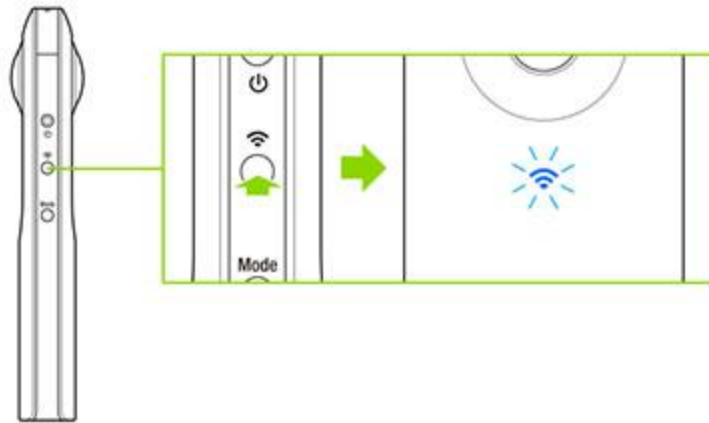
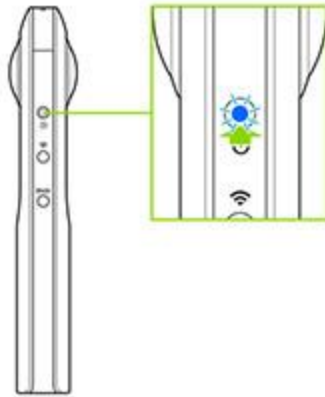

STEP1

Starting the camera

1. Press and hold the power button to start the camera.
2. Confirm that the wireless lamp is flashing. If it is off, press the wireless button.

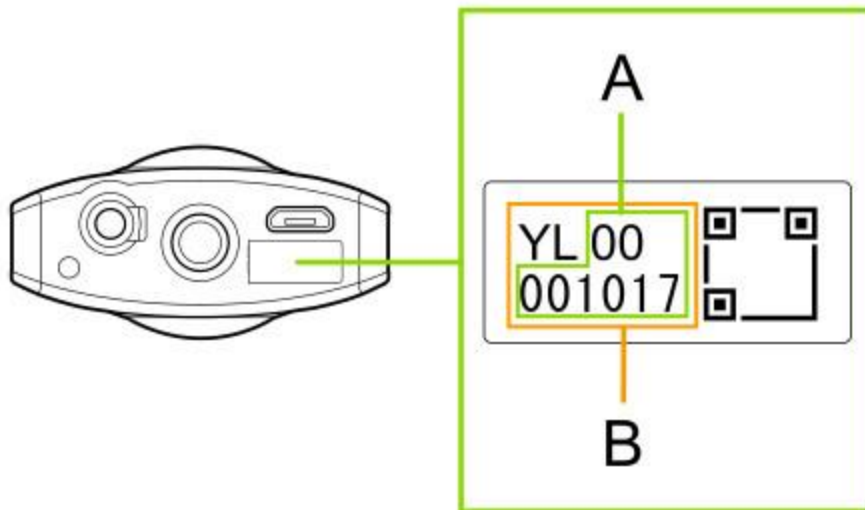

STEP2

Connecting the camera to a smartphone

1. Display the Wi-Fi™ settings of the smartphone.
2. Check the serial number printed at the bottom of the camera. * The serial number printed at the bottom of the camera is the same as the SSID and password. 3. Select "THETA*****.OSC" from the network list and enter the password. * "*****" of SSID part is indicated by (B).
- * The password is indicated by (A). 4. When the wireless lamp lights in blue, the camera is connected to the smartphone.

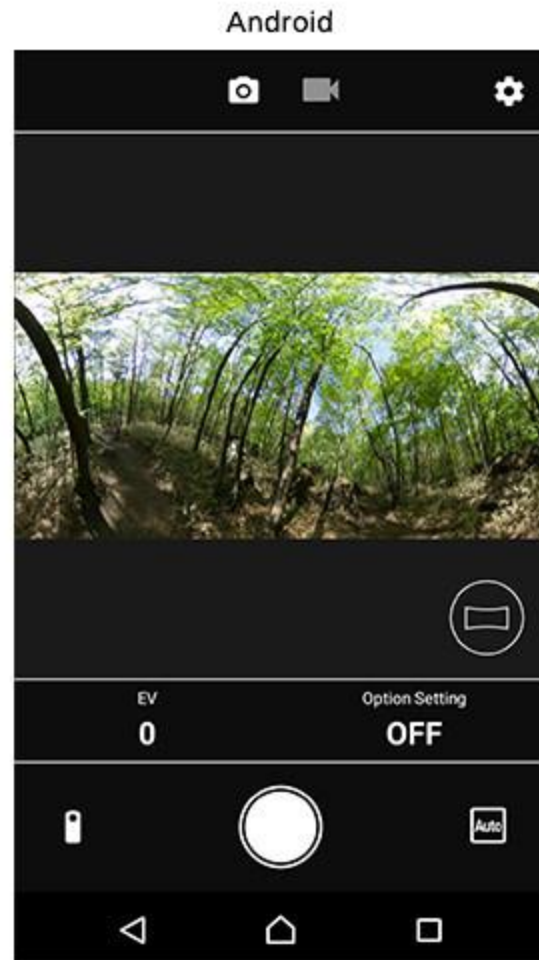
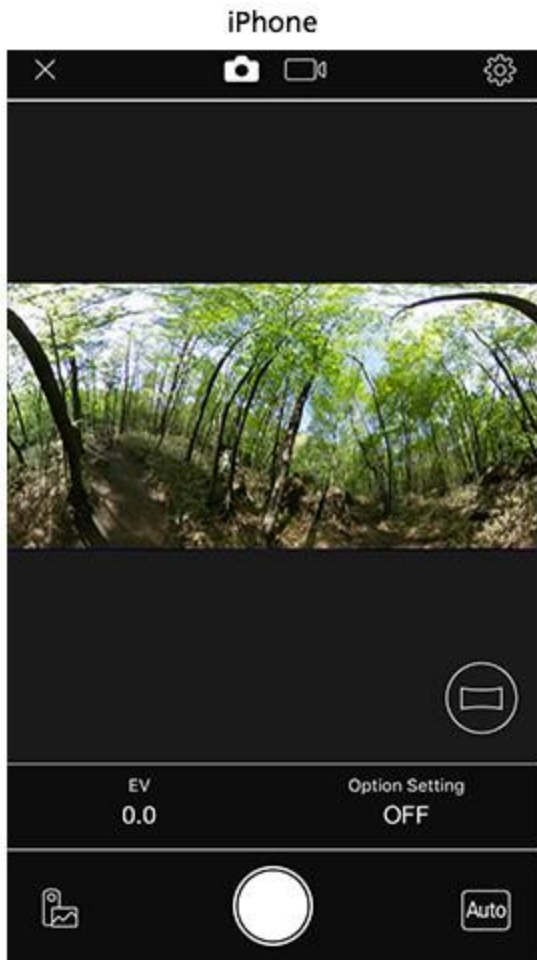

STEP3

Starting the smartphone app "RICOH THETA S"

1. Start "RICOH THETA S" app on the smartphone.
2. Tap "Cam images" on the bottom left of the screen.

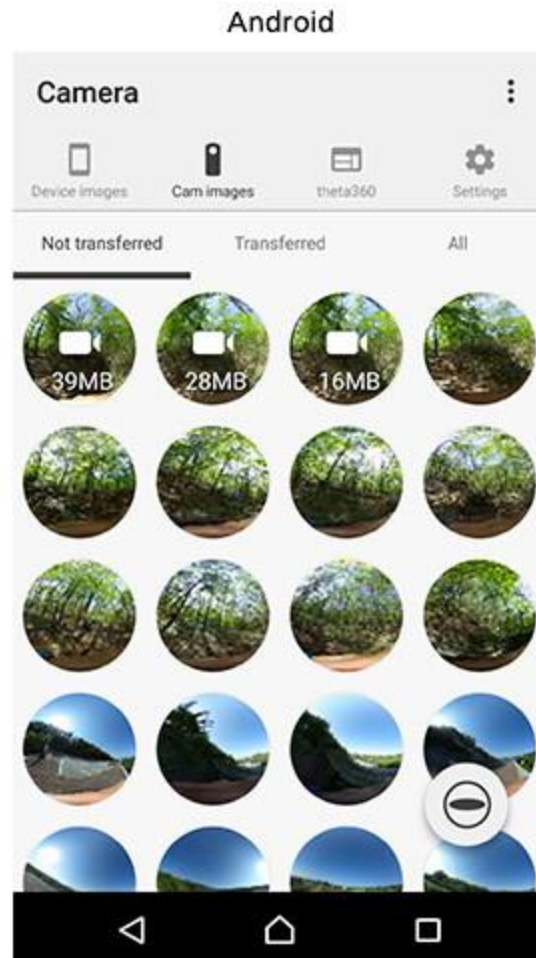

STEP4

Transferring videos

1. Tap "Cam images".
2. Start transfer by tapping [Thumbnail] for the video you want to transfer.
 - The video camera mark and file size are displayed on the videos.
3. After the transfer is completed, the playback is available.

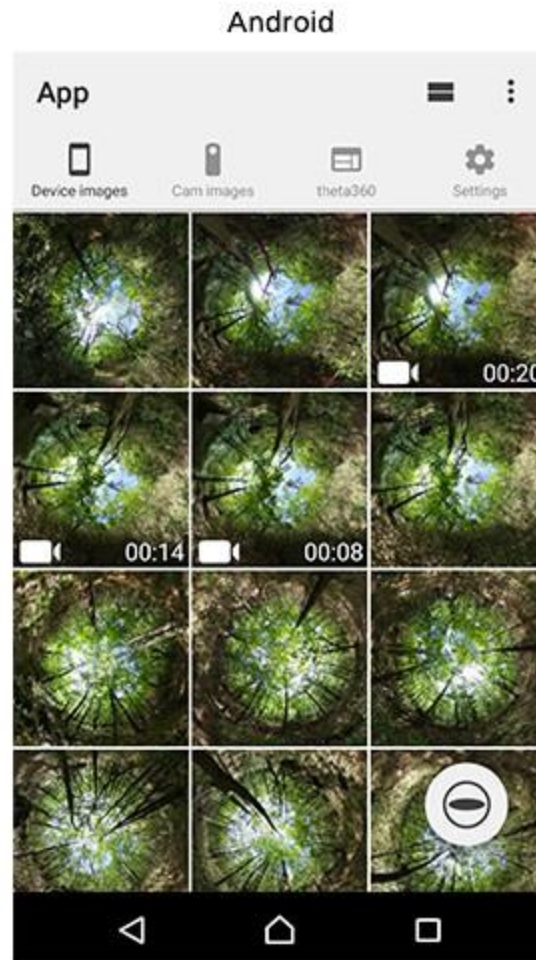
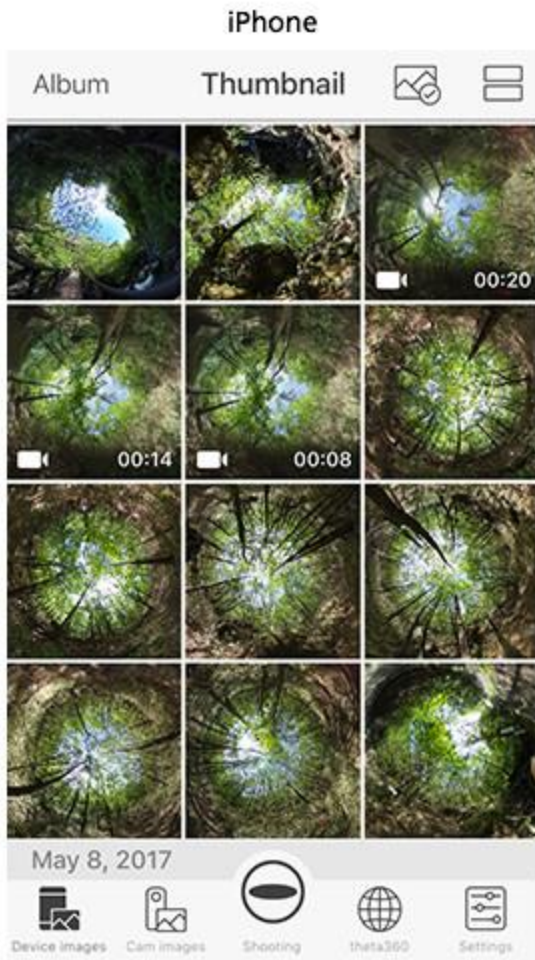

STEP5

Viewing video

From the next time it can be viewed from the [Device images].

* Note that if an image is deleted from the "Photos" App, it is also deleted from "Device images".

View examples on the theta360.com site

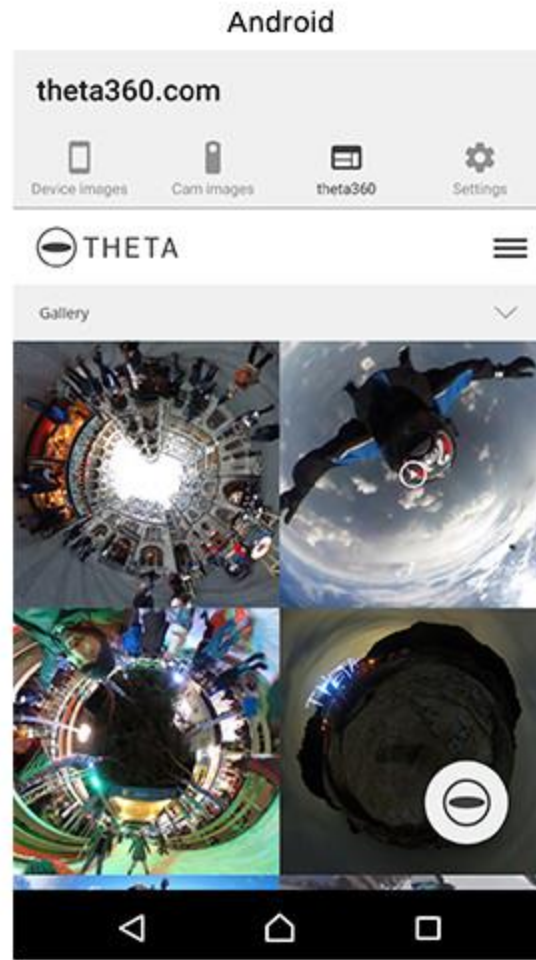
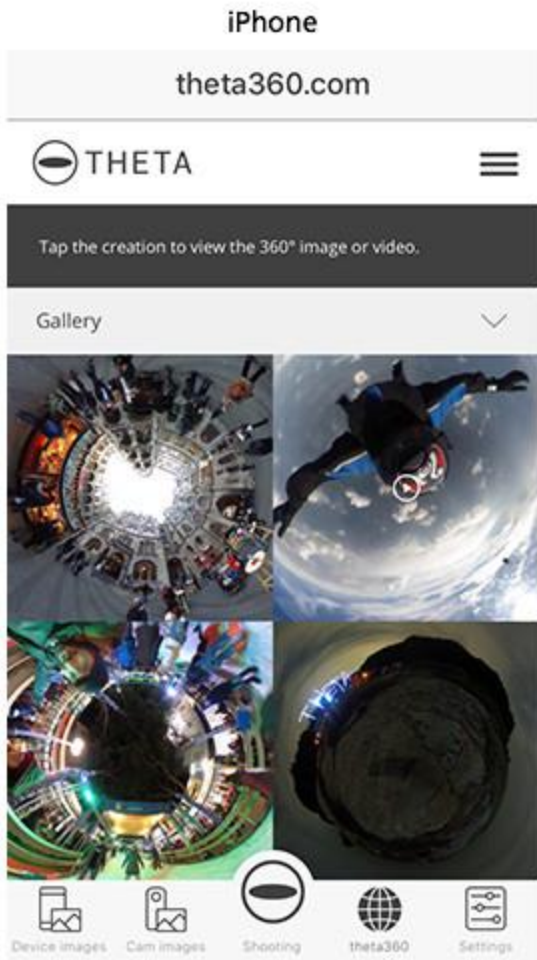

STEP1

Starting the smartphone app "RICOH THETA S"

1. Start "RICOH THETA S" app on the smartphone.
2. Tap "theta360".
3. Tap the video you want to watch.

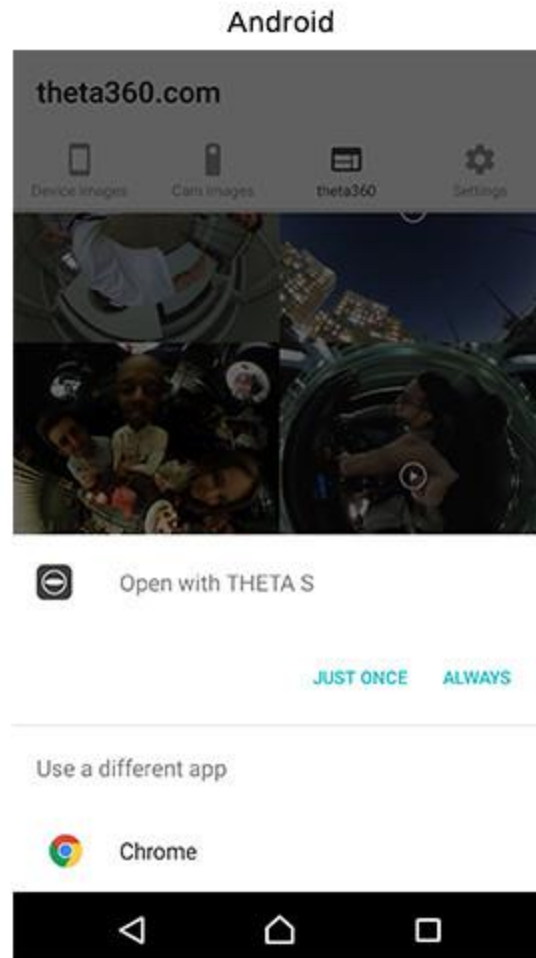
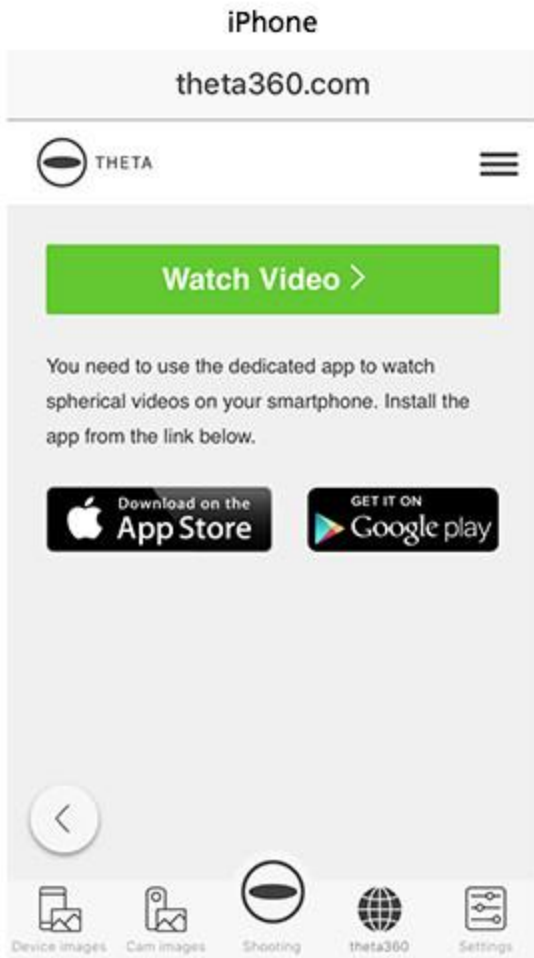

STEP2

Viewing videos

iPhone: Tap "WATCH Video".

Android: [JUST ONCE] or [ALWAYS] -Open with THETA S.

Viewing video on your computer

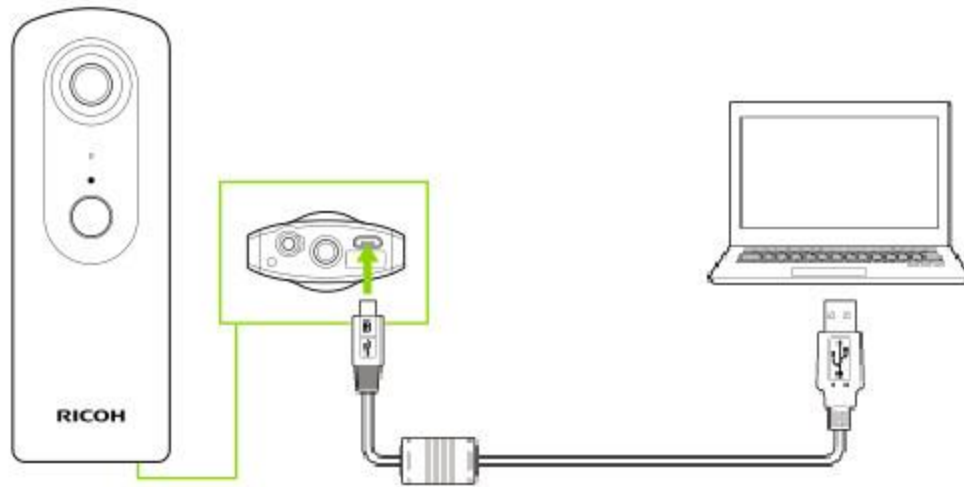

STEP1

Saving video onto your computer

1. Connect the camera to the using the provided USB cable.

Windows:

2. Select "Open device to view files".
3. Open the folder of [DCIM]-[***RICOH] and save video file (.mp4) onto your computer from the camera.

Mac:

2. Using the "Photos" app or "Image Capture", import image to your Desktop, or other location.



Drag & drop the spherical image

STEP2

Selecting video

Start the computer application, and then drag and drop imported videos (.mp4).

* You can also launch it by selecting [File] >> [Open] in the menu.

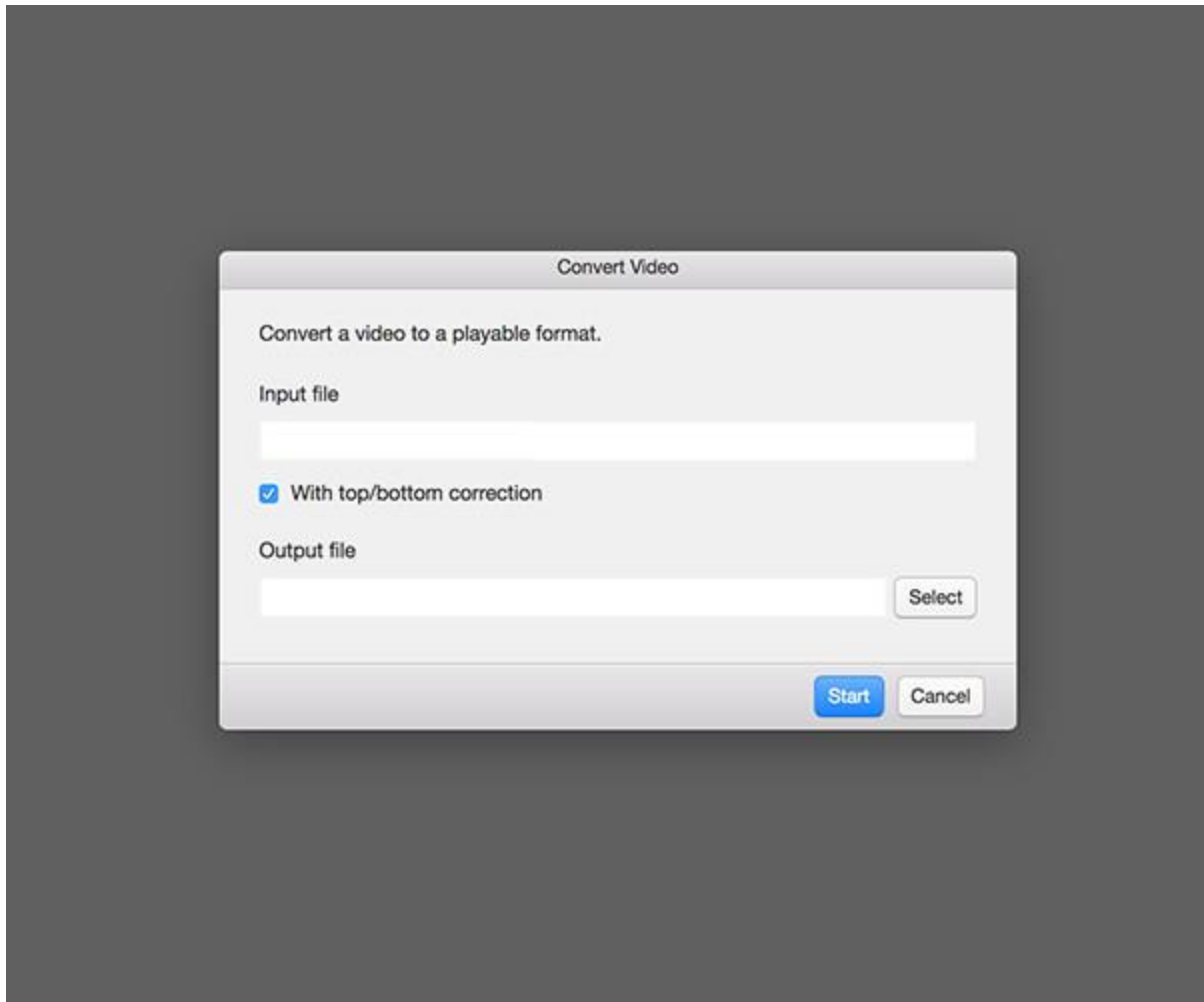

STEP3

Viewing video

1. Click [Select].
2. Select the folder to save the file and click [Start].
3. After conversion of the video file, playback starts.

- * At the next playback, choose the video file (.mp4) converted by selecting [File] >> [Open].
- * You can not directly view the image in the camera. Save the file to your computer to view it.