

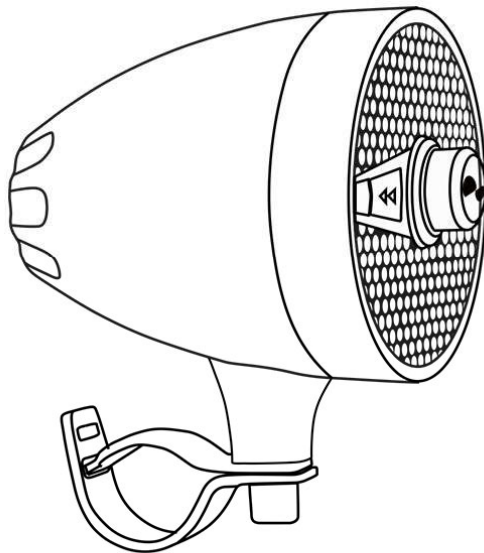

User Guide



LX-S3

Motorcycle Waterproof Bluetooth Speaker





LEXIN™

LX-S3
BLUETOOTH SPEAKER

Table of Contents

1.Introduction.....	1
2.Package Contents.....	1
3.Installation Instructions.....	2-3
4.General Operation Instructions.....	4
- Powering On/Off	
- Pairing LX-S3 with a Mobile Phone	
5.Controls and Functions.....	4
6.Technical Specification.....	5



LEXIN™

LX-S3 BLUETOOTH SPEAKER

1. Introduction

The LX-S3 is a waterproof 3” motorcycle speaker with specification v4.0 Bluetooth supporting A2DP stereo, FM Radio & 100W power amplifier built inside the housing. You can stream the stereo music wirelessly from the Bluetooth mobile phone, or USB audio source.(Note: only compatible with USB 3.0 below 32 GB)

2. Package Contents



- LX-S3 Main Speaker x1 and Slave Speaker x1
- Upper and Lower Bracket x4
- Power Cord x1
- Non-slip Meson x2
- Screw x 4
- Screw Driver x1
- Bushings x6
- Ties x4
- Antenna x1



LEXIN™

LX-S3 BLUETOOTH SPEAKER

Knob
Switch Mode Bluetooth/FM/USB Music
Play/Pause
Power On/Off
Volume Control

Prev/Up
Next/Down



3. Installation Instructions





LEXIN™

LX-S3 BLUETOOTH SPEAKER

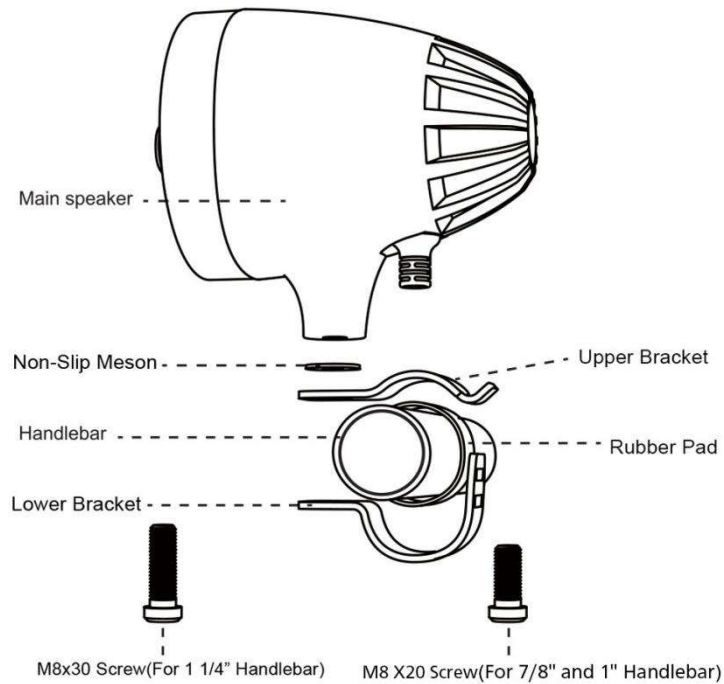

Step 1: Mount each speaker with its clamp to the handlebar of the motorcycle.

Note: Different size handlebar please insert different slot of the bracket as below.



Step 2: Plug the speaker connector of the main speaker to the slave speaker. (Fig. ①)

Note: Please remember the two arrows on each connectors should be on one line.





LEXIN™

LX-S3 BLUETOOTH SPEAKER

Step 3: Connect the RED power wire to the positive of the motorcycle battery, and BLACK wire to the negative. Then plug in the power cable to the main speaker.(Fig.②)

Step 4: Connect the external antenna to the main speaker antenna connector.(Fig③)



Step 5: Find a place to locate the antenna with 3M adhesive on the motorcycle, and extend the external antenna for FM reception when used.



4. General Operation Instructions

4.1 Power On

Short press the knob to power on the Bluetooth speaker.

4.2 Power Off

Press & hold the knob for 2 seconds to power off the Bluetooth speaker.

4.3 Charge Mobile Phone

Plug in the USB Charging cable to the USB port to charge mobile phone, or any DC 5V electronics devices. The charging power output is 2A.

Note: For waterproof remember to cover the USB port when you don't use it.



4.4 Pairing a Mobile Phone

- Power on the LX-S3, there will be voice prompt “Bluetooth Mode” , and the LED light on the speaker will blink blue to enter pairing mode;
- Search for Bluetooth devices on your mobile phone. The speaker will be listed on your mobile phone as “LX-S3” ;
- Your mobile phone will confirm that pairing is complete, then the LED light on the speaker will stay on blue.

5. Controls and Functions

5.1 Volume and Music Control

You can easily adjust the volume by rotating the knob clockwise for volume up or counter clockwise for volume down. You will hear a tone when the volume reaches maximum or minimum level. Short press the knob for play and pause the music.

5.2 Switch Mode

Double click the knob quickly to switch mode between Bluetooth/FM/USB Music.

5.3 FM Tuner

When switch from Bluetooth Mode to FM Tuner, there is a voice prompt “FM Tuner”;

- Press Up/Down button to search radio station
- Press & hold Up/Down button to automatic search.

5.4 Bluetooth Mode

When switch from FM mode to Bluetooth Mode, there is a voice prompt “Bluetooth” .

- Press Next/Previous button to track forward or back forward.

5.5 USB Music Mode

- Press Next/Previous button to track forward or back forward.

Note: The USB Mode can only be switched when there is an external USB audio source connected.

6. Important Note

Please don't play the music over half an hour if you don't start the engine, or the battery will be drained quickly.

Also if the battery power is lower than 11V, you cannot power on the speaker.



LEXINTM

WWW.LEXINMOTORCYCLE.COM

✉ **tech@lexinmotorcycle.com**

☎ **+1 (800) 380-8248**