

C-Hopetree®

Imagine...Create

A Frame Bookcase

PLEASE READ CAREFULLY AND RETAIN FOR FUTURE REFERENCE

SAFETY WARNING

- This product contains small parts and sharp points, keep away from children and pets until assembly is complete.
- Do not sit or stand on the product under any circumstances.
- Serious or fatal crushing injuries can occur from furniture tip-over accidents. To prevent this product from tipping over it should be permanently fixed to a wall. Fixing devices for the wall are **NOT** included with this product as different wall materials require different fixing devices. You should use a fixing device suitable for the walls in your home. For advice on suitable fixing devices contact your local specialized hardware or DIY shop.
- When using this product basic common-sense safety precautions should be followed to reduce the risk of personal injury and/or damage to the product.





IMPORTANT INFORMATION









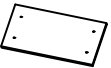

- Never use power tools to assemble this product.
- Clean only with a soft damp cloth, do not use abrasive cleaning products.
- Do not place hot items directly on any laminate surfaces.
- Take care when placing objects on the shelves or tabletops as the surface can be scratched.
- Maximum safe individual shelf load 25lbs/11kgs.

BEFORE YOU START

- Check you have all the listed parts before you start assembling.
- In the event of missing or damaged parts, contact our customer support team.
- We suggest assembling on a soft surface such as a drop sheet or rug to avoid scratching.
- Assembly will be made easier if two people work together.

PARTS LIST

Item	Picture	Qty	Description
A		4	Lower Leg
B1		2	Upper Right Leg
B2		2	Upper Left Leg
C		6	Horizontal Brace

D		1	Upper Laminate Shelf
E		1	Middle Laminate Shelf
F		1	Lower Laminate Shelf
G		2	Joining Bracket
H	 M6*12	8	Flat Head Hex Bolt - M6*12mm
I	 M6*25	12	Flat Head Hex Bolt - M6*25mm
J	 M6	20	Flat Washer - M6
K	 M4*22	12	Pan Head Bolt - M4*22mm
L	 M6	24	Plastic Bolt Head Cover - M6
M	 M4	12	Flat Washer - M4
N	 M6	1	Hex Wrench-Screwdriver - M6

ASSEMBLY INSTRUCTIONS

Step 1

Take two lower legs (A) making sure the plastic leg connectors are pointing upwards and form into a rectangle shape using 2 horizontal braces (C), secure the braces to the lower legs using parts I and J (25mm M6 bolts and M6 washers). Finger tighten only at this stage. Repeat this step for the other two lower legs.

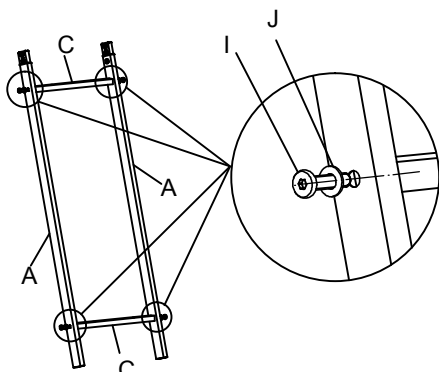

Step 2

Take one upper right leg (B1) and one upper left leg (B2) and form into a rectangle shape using 1 horizontal brace (C), secure the brace to the upper legs using parts I and J (25mm M6 bolts and M6 washers). Finger tighten only at this stage. Repeat this step for the remaining upper left and right legs.

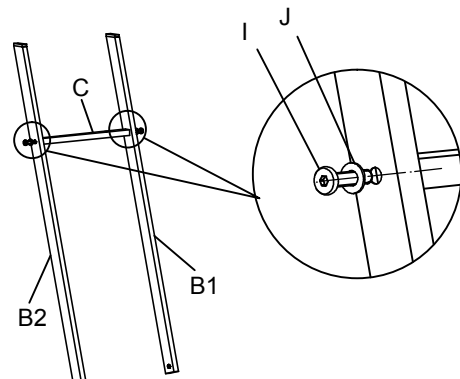

Step 3

Take one lower leg frame (assembled in step 1) and insert into one upper leg frame (assembled in step 2) over the plastic connector block. Fix using parts H and J (12mm M6 bolts and M6 washers). Finger tighten only at this stage. Repeat this step for the remaining lower leg frame.

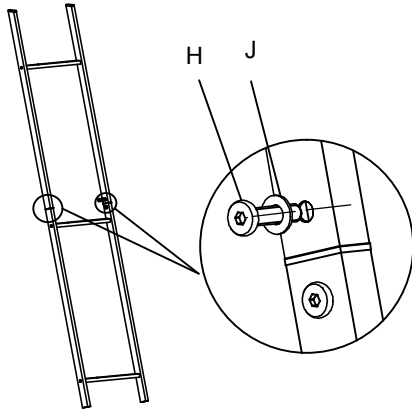

Step 4 (At this stage a second pair of hands will be very helpful.)

Take the two assembled frames and join together at the top using parts G, H and J (the joining brackets, 12mm M6 bolts and M6 washers). Finger tighten only at this stage.

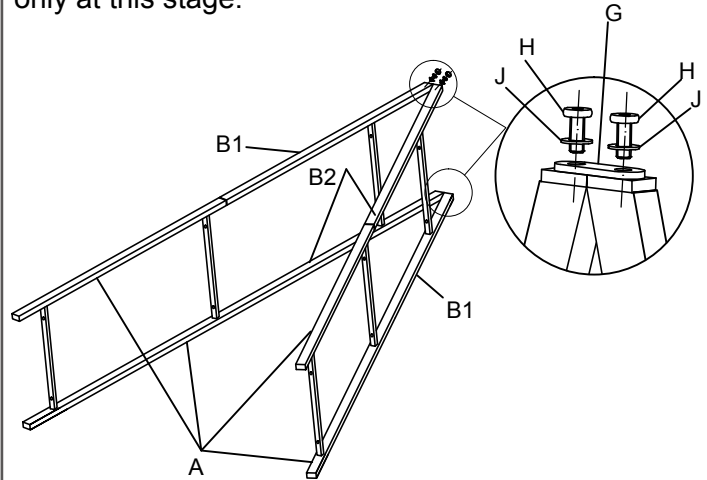

Step 5

Fit the lower, middle and upper shelves (D, E and F) face side up, align the holes in the frame and the shelf and fix in place using parts K and M (22mm M4 bolts and M4 washers).

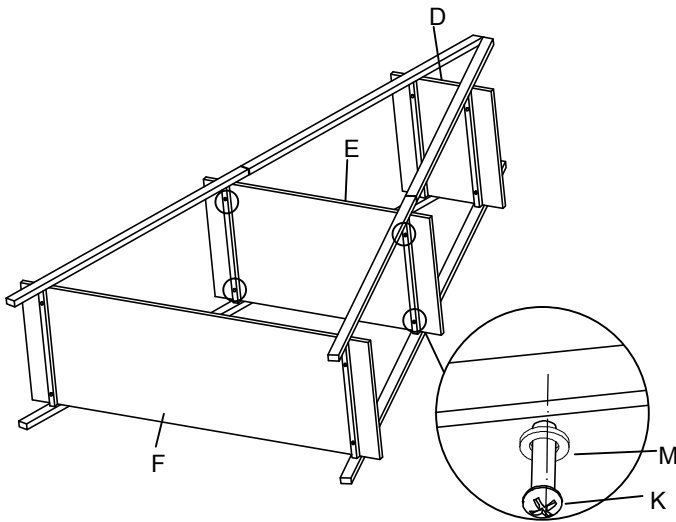

Step 6

Carefully stand right way up, locate in the final position and firmly hand tighten all the bolts using the hex wrench-screwdriver supplied. Take care not to over tighten the bolts as damage may occur. Cover the visible M6 bolt heads with plastic bolt head covers (L) if desired.

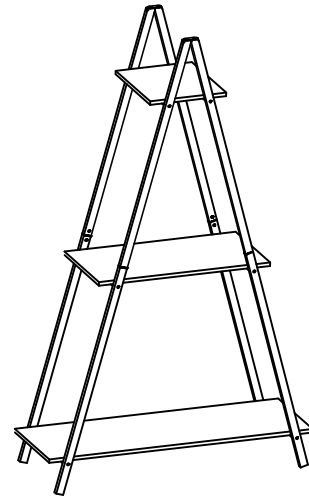

CUSTOMER SUPPORT

For all service related inquiries including missing or damaged parts and assembly issues please email service@c-hopetree.com directly. We promise to respond to your email within 24 hours, and we guarantee that we will fix the problem to your complete satisfaction.

Your complete satisfaction matters to us, so if our product hasn't met or exceeded your expectations, or if you are having any difficulty with assembly, missing or damaged parts, please email our customer support team directly, let us know the full details of the issue (attaching clear pictures to your email will always help us to better understand exactly what the problem is). We do ask that you reach out to our customer support team directly before leaving any negative review or feedback on Amazon.