

Boltune

ASIA PACIFIC

E-mail:

support.jp@boltune.com(JP)

JP Importer: 株式会社SUNVALLEY JAPAN

Address: 〒104-0032 東京都中央区八丁堀3丁目18-6 PMO京橋東
9F

EUROPE

E-mail:

support.uk@boltune.com(UK)

support.de@boltune.com(DE)

support.fr@boltune.com(FR)

support.es@boltune.com(ES)

support.it@boltune.com(IT)

EU Importer: ZBT International Trading GmbH

Address: Halstenbeker Weg 98C, 25462 Rellingen, Deutschland

NORTH AMERICA

E-mail:

support@boltune.com(US)

support.ca@boltune.com(CA)

US Distributor: SUNVALLEYTEK INTERNATIONAL INC.

Address: 46724 Lakeview Blvd, Fremont, CA 94538

MANUFACTURER

Manufacturer: Shenzhen NearbyExpress Technology
Development Co.,Ltd.

Address: 333 Bulong Road, Shenzhen, China, 518129



Boltune

Model: BT-BR001

BOLTUNE BLUETOOTH RECEIVER

User Guide

BT-BR001_V1.1

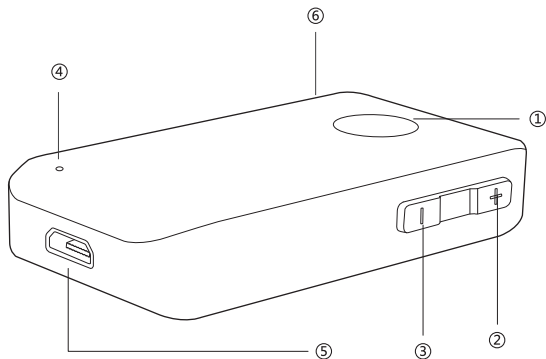

Product Diagram

- ① Power Button / LED Indicator
- ② Volume + / Next Track
- ③ Volume - / Previous Track
- ④ Microphone
- ⑤ Micro USB Charging Port
- ⑥ 3.5mm Audio Output Port

Package Contents

- 1×Boltune BT-BR001 Wireless Receiver
- 1×USB Charging Cable
- 1×3.5mm Audio Cable
- 1×3.5mm Audio Adapter
- 1×User Guide

How to Use

1. Charging

- 1) Connect the charging port with any USB charging adapter or active computer USB port.
- 2) Charging will start automatically with the LED indicator turning green.
- 3) The receiver is fully charged when the LED indicator turns off.

Note: Charge the receiver at least once every 6 months when not using for a long time.

2. Pairing

- 1) Make sure the receiver and your Bluetooth® device are next to each other (within 3 feet / 1 meter).
- 2) The first time you use the receiver, press and hold the Power Button until the LED indicator flashes red
- 3) Activate Bluetooth® on your phone and search for the nearby Bluetooth® connections.
Find "Boltune BT-BR001" in the search results. Tap on the name to connect. Once connected, the LED indicator will flash blue.

Note: The Bluetooth® receiver can remember previously paired devices.

Button Control

Function	Operation
Power on / off	Press and hold the Power Button until the LED Indicator flashes / turns off
Play / Pause / Answer / Hang up phone call	Press the Power Button once
Reject phone calls	Press and hold the Power Button for 2 seconds
Redial	Press the Power Button twice
Volume + / -	Press and hold the Volume + / - Button
Previous / Next Track	Press the Volume + / - Button



The *Bluetooth*® word mark and logos are registered trademarks owned by the Bluetooth SIG, Inc. and any use of such marks by Sunvalleytek International Inc. is under license. Other trademarks and trade names are those of their respective owners.

FCC Compliance

NOTE: This equipment has been tested and found to comply with the limits for a Class B digital device, pursuant to part 15 of the FCC Rules. These limits are designed to provide reasonable protection against harmful interference in a residential installation. This equipment generates uses and can radiate radio frequency energy and, if not installed and used in accordance with the instructions, may cause harmful interference to radio communications. However, there is no guarantee that interference will not occur in a particular installation. If this equipment does cause harmful interference to radio or television reception, which can be determined by turning the equipment off and on, the user is encouraged to try to correct the interference by one or more of the following measures:

- Reorient or relocate the receiving antenna.
- Increase the separation between the equipment and receiver.
- Connect the equipment into an outlet on a circuit different from that to which the receiver is connected.
- Consult the dealer or an experienced radio/TV technician for help

Changes or modifications not expressly approved by the party responsible for compliance could void the user's authority to operate the equipment.

This device complies with Part 15 of the FCC Rules. Operation is subject to the following two conditions:

- (1) this device may not cause harmful interference, and
- (2) this device must accept any interference received, including interference that may cause undesired



WEEE Compliance

Correct Disposal of This Product (Waste Electrical & Electronic Equipment)

(Applicable in countries with separate collection systems)

This marking on the product, accessories or literature indicates that the product and its electronic accessories should not be disposed of with other household waste at the end of their working life. To prevent possible harm to the environment or human health from uncontrolled waste disposal, please separate these items from other types of waste and recycle them responsibly to promote the sustainable reuse of material resources. Household users should contact either the retailer where they purchased this product, or their local government office, for details of where and how they can take these items for environmentally safe recycling. Business users should contact their supplier and check the terms and conditions of the purchase contract. This product and its electronic accessories should not be mixed with other commercial wastes for disposal.