

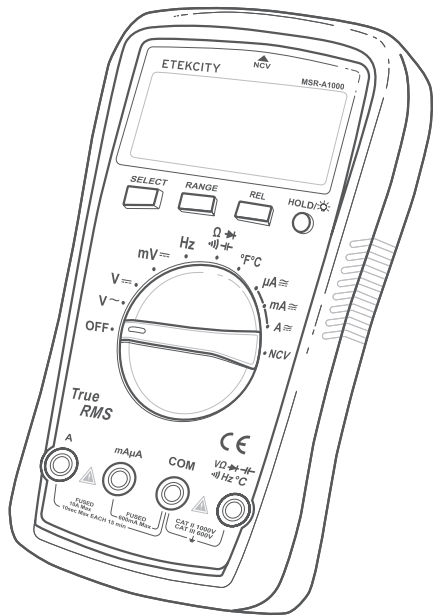

Digital Multimeter

Model No.: MSR-A1000



Questions or Concerns? support@etekcity.com • (855) 686-3835

Thank you for purchasing the **MSR-A1000
Digital Multimeter** by Etekcity.

If you have any questions or concerns, please reach out to our helpful Customer Support Team at support@etekcity.com. We hope you enjoy your new multimeter!

BECOME AN ETEKCITIZEN

Get exclusive deals, giveaways, and product registration. Better products for better living. Find us at etekcity.com

Table of Contents

Package Contents	3
Safety Information	4
• Electrical Symbols	5
Multimeter Features	6
• Display Symbols	7
• Button Functions	8
Operation	9
• General Use	9
• DC/AC Voltage Measurement	10
• Resistance Measurement	11
• Continuity Measurement	12
• Diode Measurement	13
• Capacitance Measurement	14
• DC/AC Current Measurement	15
• Temperature Measurement	16
• Frequency Measurement	16
• Non-Contact AC Electric Field Sensing	17
• Other Functions	18
Maintenance	19
• General Maintenance	19
• Replacing the Batteries	19
• Replacing the Fuses	20
Technical Index	21
• Specifications	21
Warranty Information	28
Customer Support	30

Package Contents

1 x Digital Multimeter
2 x 1.5V AA Batteries (Pre-Installed)
2 x Test Leads
1 x Temperature Probe
2 x Alligator Clip Cables
1 x Hook Clip
1 x User Manual

Safety Information

The following safety certification standards apply to this multimeter:

- CE certifications
- EN 61010-1:2010 and EN 61010-2-030:2010
- EN 61326-1:2013 and EN 61326-2-2:2013
- Overvoltage category: CAT II 1000V/CAT III 600V
- Double insulation
- Material pollution grade II

Only use the multimeter as directed, or the multimeter may be damaged, and you may be seriously injured.

In this manual:

 **WARNING** identifies conditions and actions that are dangerous to the user or may damage the multimeter and test leads.



WARNING

- To reduce the risk of fire, electrical shock, or other serious injury, please read and follow all instructions and warnings in this manual.
- The person responsible for this equipment must ensure that all users understand and follow the instructions.
- To avoid electric shock, **never** connect leads to power sources that may exceed 1000V.
- Check the insulation layers (protective coverings) of the multimeter and the test leads before use. They should be in good condition without any damage or broken wires.
- To avoid electric shock, **do not** use the multimeter if the rear cover or the protective jacket is not fully in place.
- **Do not** use the multimeter if it is damaged, if any part is removed, or if you suspect that the multimeter is not working correctly.
- **Always** inspect all parts of the multimeter and the test leads before using. **Always** replace damaged test leads.
- **Do not** apply more than 1000V between the multimeter terminal and the ground.

WARNING

- To avoid electric shock, be extremely cautious when the measured voltage is higher than DC 60V or AC 30Vrms.
- To avoid damaging the multimeter, **always** turn the rotary dial to the correct position when using.
- **Do not** change the range on the rotary dial while the test leads are connected to a power source.
- **Do not** alter the internal circuitry of the multimeter. This may result in serious injury.
- **Do not** use or store the multimeter in wet or humid environments, in very high temperatures, around explosive or flammable substances, or in areas with strong magnetic fields. The multimeter will not perform correctly, which may create a safety hazard.
- **Never** touch any exposed metal while measuring. Keep fingers behind the finger guards of the test leads.
- Avoid working alone.
- **Do not** allow children to operate or play with this multimeter.
- Household use **only**.

Electrical Symbols

	High Voltage Hazard
	Double Insulation
	Warning
	AC
	DC
	Grounding
	Conforms to European Union Directives





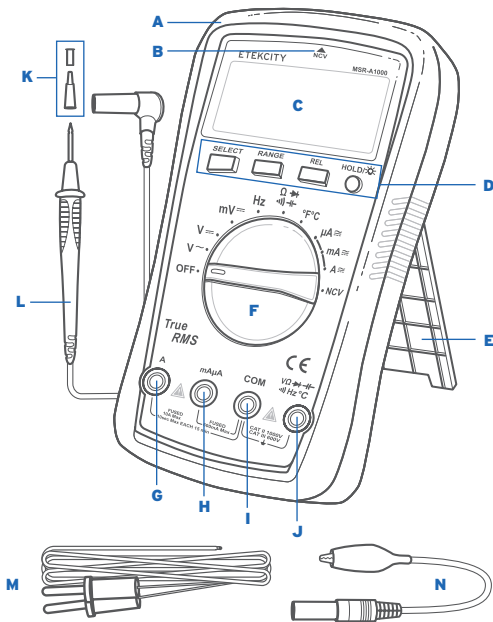

Multimeter Features

The MSR-A1000 is a multifunctional multimeter with a large LCD screen, true RMS, and both auto and manual range. This multimeter is designed with a new intelligent ADC chip, overvoltage and overcurrent alarms, lightning protection (6kV), and high voltage protection. It is an ideal digital multimeter for commercial and industrial electricians.

- A. Protective Jacket
- B. Internal NCV Sensor
- C. LCD Screen
- D. Function Buttons
- E. Stand
- F. Rotary Dial
- G. **A** Input Terminal
- H. **mA/uA** Input Terminal
- I. **COM** Input Terminal
- J. **V Ω \rightarrow \leftarrow \rightarrow \leftarrow Hz $^{\circ}$ C** Terminal
- K. Test Lead Caps
- L. Test Lead
- M. Type K Thermocouple Temperature Probe
- N. Alligator Clip Cable



Display Symbols

Symbol	Description
APO	Auto power-off
	High voltage warning
	Data hold is active
-	Indicates a negative reading
AC	AC measurement indicator
DC	DC measurement indicator
	Low battery indicator
NCV	Non-contact voltage detector
OL	Input value is too large for the selected range
	Diode test
	Continuity test
	Capacitance test
Ω	Ohms (resistance)
kΩ	Kilohm, 1×10^3 or 1,000 ohms

Symbol	Description
MΩ	Megaohm, 1×10^6 or 1,000,000 ohms
V	Volts (voltage)
mV	Millivolt, 1×10^{-3} or 0.001 of a volt
A	Amperes or amps (current)
mA	Milliamp, 1×10^{-3} or 0.001 of an amp
μA	Microamp, 1×10^{-6} or 0.000001 of an amp

Button Functions

Button	Description
SELECT	Press to switch between resistance/diode/continuity/capacitance, °C/°F temperature, and AC/DC current.
RANGE	Press to switch to manual range at ACV, DCV, mV, resistance, uA, mA and A positions.
REL	Press to clear the base value at ACV, DCV, mV, resistance/capacitance, uA, mA and A positions.
HOLD/☼	Press to enable/disable the data hold mode (hold the current measurement on the display). Press and hold this button for 2 or more seconds to turn the backlight on or off.

Operation

General Use

- Inspect the test leads for damaged insulation or exposed metal parts. Check the leads for continuity. Replace damaged test leads if necessary.
- Keep your fingers behind the finger guards at all times when handling the test probes. [\[Figure 1.1\]](#)
- **Always** remove the test leads from the item being measured before changing the range.
- Check the fuses in the multimeter before measuring current. **Always** make sure power to the circuit has been shut off before connecting the multimeter to the circuit. Once you have properly connected the multimeter, power on the circuit.
- Remember to replace the batteries as soon as the low battery indicator  appears (see **Replacing the Batteries**, page 19). The multimeter may produce incorrect readings if it is operated with a low battery.
- When measuring low voltages, the multimeter reading will fluctuate a small amount. This is due to ambient electricity in the air.
- **Always** make sure the rotary dial is in the correct position before using the multimeter to measure anything.



Figure 1.1

AC Voltage, DC Voltage, and DC Millivoltage Measurement

⚠ WARNING

- To avoid electric shock, DC measurement should be less than 1000Vrms, and AC measurement should be less than 750Vrms. It is possible to measure higher voltage, but this may damage the multimeter and cause personal injury.
- **Always** take extra care to avoid electric shock when measuring high voltages.

1. Turn the rotary dial to the AC voltage, DC voltage, or DC mV (millivolts) position. [\[Figure 2.1\]](#)
2. Insert the **black test lead** into the **COM** terminal, and the **red test lead** into the **VΩ** \rightarrow \leftarrow \rightarrow \leftarrow Hz °C terminal.
3. Connect the test leads in parallel to the object being measured. Hold them in place until the reading on the display stabilizes.

Note:

- If the range of the measured voltage is unknown before measuring, select the maximum range and then gradually reduce the measuring range until the multimeter shows an accurate reading.
- The display will show “**OL**” if the reading is over range (if there is an overload within the selected voltage range). Select a higher range to get a correct reading.
- In each range selection, the multimeter has an input impedance of 10M Ω . This load effect can cause measurement errors in high impedance circuits. If the circuit impedance is less than or equal to 10k Ω , the error can be ignored (0.1% or less).
- Before using the multimeter, try measuring a known voltage to verify it is working correctly.

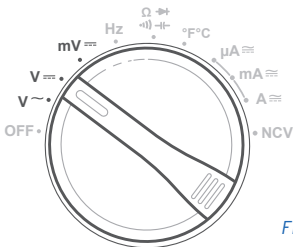

Figure 2.1

Resistance Measurement

WARNING

Before measuring, switch off the power supply of the circuit, and fully discharge all capacitors.

1. Turn the rotary dial to the resistance (Ω) position. Press **SELECT** once to choose resistance test. [Figure 3.1]
2. Insert the **black test lead** into the **COM** terminal, and the **red test lead** into the **V Ω \rightarrow \leftarrow \leftarrow Hz $^{\circ}$ C** terminal.
3. Connect the test leads in parallel to the object being measured. Hold them in place until the reading on the display stabilizes.

Note:

- If the resistance reading is greater than 0.5 when the test leads are shorted (connected to each other), check if the test leads are loose or damaged.
- The display will show “**OL**” if there is an open circuit for the tested resistor or if the resistor value is higher than the maximum resistance range of the multimeter.

- When measuring low resistance, the resistance of the test leads may affect the test result, causing a 0.1 Ω -0.2 Ω measurement error. To get an accurate measurement, first test the resistance of the test leads by connecting them to each other, and subtract this value from the final measurement result.
- When testing high-resistance objects, it is normal to wait for several seconds to obtain a stable reading ($>1\text{M}\Omega$).

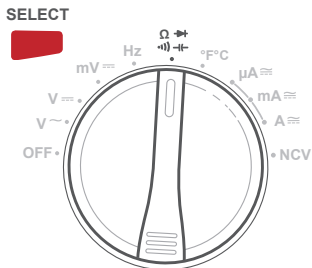



Figure 3.1

Diode Measurement

WARNING

Before measuring, switch off the power supply of the circuit, and fully discharge all capacitors.

This test sends a current through a diode or a semiconductor junction, then measures the voltage drop across the junction.

1. Turn the rotary dial to the diode () position. Press **SELECT** twice to choose the diode test. [Figure 5.1]
2. Insert the **black test lead** into the **COM** terminal, and the **red test lead** into the **VΩ  Hz °C** terminal.
3. Connect both test leads to both ends of the PN junction. Hold the leads in place until the reading on the display stabilizes.

Note:

- The display will show “**OL**” if the test leads are incorrectly connected, if the polarity is reversed, or if the diode is open.
- The normal value for a PN silicon junction is 500-800mV (0.5-0.8V).
- The diode test voltage range is about 3.0V/1.5mA.

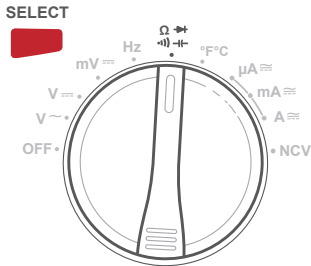

Figure 5.1

Capacitance Measurement

WARNING

Before measuring, switch off the power supply of the circuit, and fully discharge all capacitors.

1. Turn the rotary dial to the capacitance ($\text{—}|\text{—}$) position. Press **SELECT** three times to choose the capacitance test. [Figure 6.1]
2. Insert the **black test lead** into the **COM** terminal, and the **red test lead** into the **V Ω $\text{—}|\text{—}$ — Hz $^{\circ}\text{C}$** terminal.
3. Connect both test leads to both ends of the capacitor. Hold the leads in place until the reading on the display stabilizes.

Note:

- When nothing is being measured, the display will show fixed value (intrinsic capacitance). For small capacitance measurements, this fixed value must be subtracted from the measured value to ensure measurement accuracy. You can also choose the relative measurement function (**REL**) to automatically subtract the intrinsic capacitance.

- The display will show “**OL**” if the measured capacitor is short-circuited or the capacitance exceeds the maximum range.
- When measuring large volume capacitors, it is normal to wait for several seconds to obtain a stable reading.
- When measuring capacitance of 100nF or above, select relative measurement mode (**REL**) to ensure accuracy.

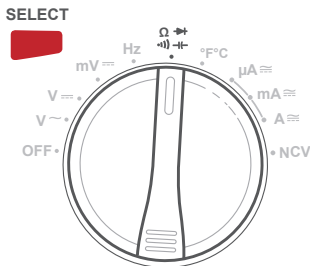

Figure 6.1

DC/AC Current Measurement

WARNING

- Before measuring, switch off the power supply of the circuit, and carefully check the input terminals and the dial position.
- To avoid electric shock or damage to the multimeter, never connect the test leads with any voltage circuit in parallel during current measurement.

1. Turn the rotary dial to the appropriate DC/AC current position. Press **SELECT** to choose AC or DC current test. [Figure 7.1]
2. Insert the **black test lead** into the **COM** terminal, and the **red test lead** into the **mA μ A** or **A** terminal.
3. Connect the test leads in series to the source or circuit being measured. Hold them in place until the reading on the display stabilizes.

Note:

- If the range of the measured current is unknown before measuring, select the maximum range and then gradually reduce the measuring range until the multimeter shows an accurate reading.
- If the **mA μ A** or **A** terminals are overloaded, the internal fuses will be damaged and must be replaced (with fuses of the same specification).
- If the test current is close to 10A, each measurement time should be less than 10 seconds. Wait 15 minutes before measuring again.

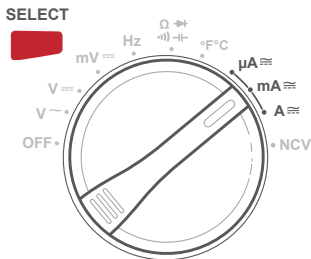

Figure 7.1

Temperature Measurement

1. Turn the rotary dial to the temperature (**°F/°C**) position. Press **SELECT** to choose Fahrenheit or Celsius units. [Figure 8.1]
2. Use the type K thermocouple temperature probe. Insert the **black test lead** into the **COM** terminal, and the **red test lead** into the **VΩ → ← ← μ) Hz °C** terminal.
3. Connect the probe on the object being measured. Hold them in place until the reading on the display stabilizes.

Note:

- If the temperature probe is not attached, the display will show "OL" when this function is selected.
- The included type K (NiCr-NiSi) thermocouple can **only** be used for temperatures lower than 482°F (250°C), or the thermocouple will be damaged. Use a different thermocouple for higher temperatures.

Frequency Measurement

1. Turn the rotary dial to the **Hz** position. [Figure 9.1]
2. Insert the **black test lead** into the **COM** terminal, and the **red test lead** into the **VΩ → ← ← μ) Hz °C** terminal.

3. Connect the test leads in parallel to the signal source. Hold them in place until the reading on the display stabilizes.

Note:

- The measurement range is 10Hz-10MHz.
- The measurement signal should be less than 30V, or measurement accuracy may be affected.

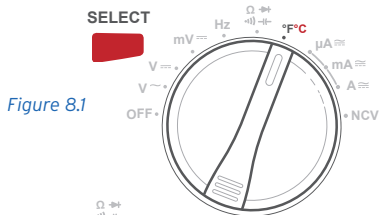

Figure 8.1

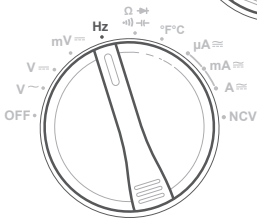

Figure 9.1

Non-Contact AC Electric Field Sensing

This test detects whether there is an AC voltage or electromagnetic field in an area, without touching the area or object being measured.

1. Turn the rotary dial to the **NCV** position. [Figure 10.1]
2. Place the front end of the multimeter near the object being measured. The intensity of the detected voltage will be displayed on the LCD in horizontal segments (up to 4 segments). [Figure 10.2] The multimeter will beep when voltage is detected. When a more intense voltage is detected, it will beep faster.

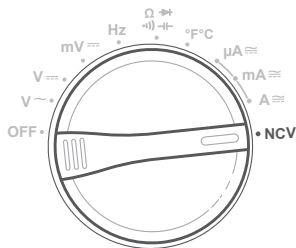

Figure 10.1

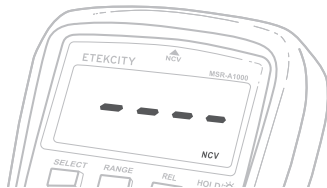

Figure 10.2

Other Functions

- The multimeter will be ready to take measurements 2 seconds after startup.
- If the multimeter is not used for 15 minutes, it will automatically turn off to save power. You can turn on the multimeter by pressing any button or turning the dial, and the multimeter will beep once.
- The multimeter will beep 5 times, 1 minute before automatic shutoff. Immediately before automatic shutoff, you will hear 1 long beep.
- To disable automatic shutoff, turn the dial to the **OFF** position, press **SELECT**, and turn on the multimeter.
- The multimeter will beep (for about 0.25 seconds) when pressing any button or turning the dial.
- If the input DC voltage is 1000V or higher, or if the AC voltage is 750V or higher, the multimeter will beep continuously to warn that the range is at its limit.
- If AC/DC current is over 10A, the multimeter will beep continuously to warn that the range is over its limit.
- **Low Battery Detection:** If the multimeter internal battery voltage is under 2.5V, the low battery symbol (🔋) will appear and flash. The multimeter will still work normally. If the battery voltage is under 2.2V, the screen will only display the low battery symbol (🔋) after startup, and the multimeter will not work.

Maintenance

General Maintenance

- Clean the multimeter with a damp cloth and mild detergent. **Do not** use abrasives or solvents.
- If you are experiencing any issues with the multimeter, please contact **Customer Support** (see page 30).
- Any calibration or maintenance must be done by qualified professionals.

Replacing the Batteries

Note:

- To avoid inaccurate measurements, replace the batteries immediately when the low battery indicator () appears on the display screen.
 - The multimeter requires two 1.5V AA batteries.
1. Disconnect the test leads and turn the rotary dial to **OFF**.
 2. Remove the protective jacket from the multimeter.
 3. Use a small screwdriver to remove the screw on the battery compartment cover on the back of the multimeter.

4. Remove the old batteries. Install 2 new 1.5V AA batteries into the compartment under the correct polarity. [Figure 11.1]
5. Replace and secure the battery compartment cover.

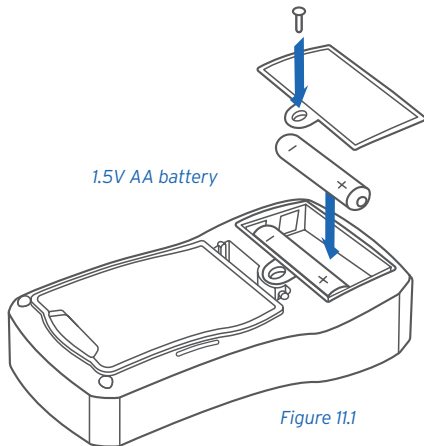

Replacing the Fuses

Note: The fuses may burn out because of overcurrent or testing voltage improperly, and the multimeter will not work correctly. Replace any burnt-out fuses.

1. Disconnect the test leads and turn the rotary dial to **OFF**.
2. Remove the protective jacket from the multimeter.
3. Use a small screwdriver to remove both screws on the bottom of the multimeter. Remove the front cover from the back cover. [\[Figure 12.1\]](#)
4. Replace the old fuses.
 - a. F1 Fuse Specifications: 0.6A/1000V
 $\Phi 6 \times 32$ mm ceramic tube
 - b. F2 Fuse Specifications: 10A/1000V
 $\Phi 6 \times 32$ mm ceramic tube
3. Replace and secure the back and front covers of the multimeter, and replace the protective jacket.

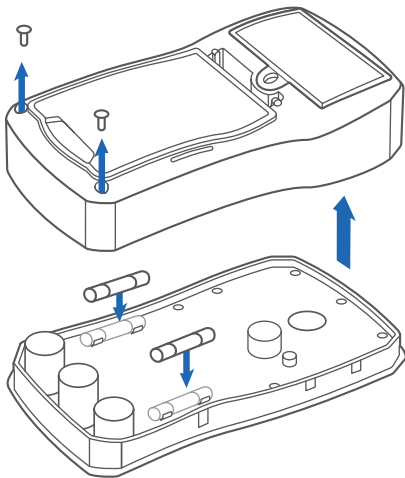

Figure 12.1

Technical Index

Specifications

Display Measurements	6000 counts with fast ADC (4 times/sec), true RMS
Capacitance Measurement	Response time <12s when capacitance $\leq 60\text{mF}$
Max voltage between input terminal and ground	1000Vrms
⚠ A Terminal	Fuse 10A H 1000V fast-acting fuse $\Phi 6 \times 32\text{mm}$
⚠ mA/μA Terminal	Fuse 600mA H 1000V fast-acting fuse $\Phi 6 \times 32\text{mm}$
Range	Auto
Backlight	Manual (Auto-Off after 30 seconds)
Display Refresh	3 times/sec
Battery	2 x 1.5V AA batteries
Operation Conditions	Operating temperature: 32°F-104°F (0°C-40°C)
	Storage temperature: 14°F-122°F (-10°C-50°C)
	Relative humidity: $\leq 75\%$: 32°F-below 86°F (0°C-below 30°C), $\leq 50\%$: 86°F-104°F (30°C-40°C)
	Operating altitude: 0-6500 ft (0-2000 m)

Technical Index (cont.)

Specifications

Dimensions	7.4 x 3.5 x 2.2 in (187 x 88 x 56 mm)
Weight	About 14 oz (~400 g) including batteries
EMC	RF field (1V/m): overall accuracy = specified accuracy + 5% of range
	RF field (>1V/m): no specified calculation
Accuracy Format	$\pm(a\%$ of reading + b digits)
Ambient temperature for high accuracy	73.4°F \pm 9°F (23°C \pm 5°C)
Relative humidity for high accuracy	\leq 75%

Features

- Drop-proof up to 3 ft (1 m)
- Protection from overvoltage shock up to 1000V, and overvoltage and overcurrent alarms
- NCV and frequency measurement
- Up to 1000V and 10A AC/DC measurement
- 1.8mA power consumption, automatic power saving extends battery life up to 500 hours

NOTE

- To ensure accuracy, the operating temperature should be within 64°F-82°F (18°C-28°C) and the fluctuation range should be within $\pm 1.8^\circ\text{F}$ (1°C).
- For higher or lower temperatures, add temperature coefficient error 0.1 x (specified accuracy) / (°F or °C).

i. AC Voltage Measurement

Range	Resolution	Accuracy
6V	0.001V	$\pm(1.0\%+3)$
60V	0.01V	
600V	0.1V	$\pm(0.8\%+5)$
750V	1V	

- Input impedance is about 10M Ω .
- **Frequency response:** 40 - 400Hz, sine wave rms (average response).
- **Max input voltage:** $\pm 750V$
- LCD shows "OL" if there is an overload within the selected range.

ii. DC Voltage Measurement

Range	Resolution	Accuracy
60mV	0.01mV	$\pm(0.7\%+5)$
600mV	0.1mV	
6V	1mV	$\pm(0.5\%+2)$
60V	0.01V	
600V	0.1V	
1000V	1V	$\pm(0.7\%+5)$

- Input impedance is about 10M Ω .
- There may be unstable readings while using the mV range when the test leads are not connected. The reading will stabilize when the test leads are connected, ± 3 digits.
- The max input voltage: $\pm 1000V$. The display will show "OL" when the input voltage is 1010V or higher.
- **Overload protection:** 1000Vrms (DC/AC)

iii. Resistance Measurement

Range	Resolution	Accuracy
600 Ω	0.1 Ω	$\pm(0.8\%+5)$
6k Ω	0.001k Ω	$\pm(0.8\%+3)$
60k Ω	0.01k Ω	
600k Ω	0.1k Ω	
60M Ω	0.01M Ω	$\pm(3.0\%+10)$

- Measurement result = reading of resistance after subtracting reading of shorted test leads
- **Overload protection:** 1000Vrms (DC/AC)

iv. DC Current Measurement

Range	Resolution	Accuracy
60 μ A	0.01 μ A	$\pm(0.8\%+8)$
600 μ A	0.1 μ A	
6000 μ A	1 μ A	
60mA	0.01mA	
600mA	0.1mA	$\pm(1.2\%+5)$
6A	0.001A	$\pm(2.0\%+5)$
10A	0.01A	

- If the input is 10A or greater, the multimeter will beep.
- If the input is greater than 10.10A, the display will show " **OL** ".
- **Overload protection:** 1000Vrms

v. AC Current Measurement

Range	Resolution	Accuracy
60 μ A	0.01 μ A	$\pm(1.0\%+12)$
600 μ A	0.1 μ A	
6000 μ A	1 μ A	
60mA	0.01mA	
600mA	0.1mA	$\pm(2.0\%+3)$
6A	0.001A	$\pm(3.0\%+5)$
10A	0.01A	



- **Frequency response:** 40-400Hz
- RMS display
- **Accuracy guarantee range:** 5-100% of range, short circuit allows least significant digit <2.
- If the input is 10A or greater, the multimeter will beep.
- If the input is greater than 10.10A, the display will show "OL".
- **Overload protection:** 1000Vrms

vi. Frequency Measurement

Range	Resolution	Accuracy
9.999Hz-9.999MHz	0.001Hz-0.001MHz	$\pm(0.1\%+5)$

- **Overload protection:** 1000Vrms (DC/AC)
- **Input amplitude:**
 - ≤ 100 kHz: 100mVrms \leq input amplitude \leq 30Vrms
 - >100 kHz-1MHz: 200mVrms \leq input amplitude \leq 30Vrms
 - >1 MHz: 600mVrms \leq input amplitude \leq 30Vrms

vii. Continuity & Diode Measurement

Range	Resolution	Accuracy
	0.1 Ω	If the measured resistance is greater than 50 Ω , the multimeter will read the circuit as open, and the multimeter will not beep.
		If the measured resistance is 10 Ω or less, the multimeter will read the circuit as well-connected, and the multimeter will beep.
	0.001V	Open circuit voltage: about 3V. Test current: about 1.5mA. Silicon PN junction normal voltage: about 0.5-0.8V.

- **Overload protection:** 1000Vrms (DC/AC)

viii. Capacitance Measurement

Range	Resolution	Accuracy
6nF	0.001nF	REL mode: $\pm(4\%+10)$
60nF	0.01nF	$\pm(4\%+5)$
600nF	0.1nF	
6 μ F	0.001 μ F	
60 μ F	0.01 μ F	
600 μ F	0.1 μ F	$\pm(5.0\%+10)$
6mF	0.001mF	
60mF	0.01mF	$\pm 10\%$

- When measuring capacitance of 100nF or above, select relative measurement mode (**REL**) to ensure accuracy.
- **Overload protection:** 1000Vrms (DC/AC)

ix. Temperature Measurement

Range			Resolution	Accuracy
°C	-40°C-1000°C	-40°C-40°C	1°C	±4°C
		>40°C-500°C		±(1.0%+4)
		>500°C-1000°C		±(2.0%+4)
°F	-40°F-1832°F	-40°F-104°F	1°F	±5°C
		>104°F-932°F		±(1.5%+5)
		>932°F-1832°F		±(2.5%+5)

- The included type K (NiCr-NiSi) thermocouple can only be used for temperature lower than 482°F (250°C). Use a different thermocouple for higher temperatures.
- **Overload protection:** 1000Vrms (DC/AC)

Warranty Information

Product Name	Digital Multimeter
Model Number	MSR-A1000
Default Warranty Period	1 year
<i>For your own reference, we strongly recommend that you record your order number and date of purchase.</i>	
Order Number	
Date of Purchase	

TERMS & POLICY

Etekcity warrants all products to be of the highest quality in material, craftsmanship, and service, effective from the date of purchase to the end of the warranty period.

Etekcity will replace any product found to be defective due to manufacturer flaws based on eligibility. Refunds are available within the first 30 days of purchase. Refunds are only available to the original purchaser of the product. This warranty extends only to personal use and does not extend to any product that has been used for commercial, rental, or any other use in which the product is

not intended for. There are no warranties other than the warranties expressly set forth with each product.

This warranty is non-transferrable. Etekcity is not responsible in any way for any damages, losses, or inconveniences caused by equipment failure by user negligence, abuse, or use noncompliant with the user manual or any additional safety, use, or warnings included in the product packaging and manual.

This warranty does not apply to the following:

- Damage due to abuse, accident, alteration, misuse, tampering, or vandalism.
- Improper or inadequate maintenance.
- Damage in return transit.
- Unsupervised use by children under 18 years of age.

Etekcity and its subsidiaries assume no liability for damage caused by the use of the product other than for its intended use or as instructed in the user manual. Some states do not allow this exclusion or limitation of incidental or consequential losses so the foregoing disclaimer may not apply to you. This warranty gives you specific legal rights and you may also have other rights which may vary from state to state.

ALL EXPRESSED AND IMPLIED WARRANTIES, INCLUDING THE WARRANTY OF MERCHANTABILITY, ARE LIMITED TO THE PERIOD OF THE LIMITED WARRANTY.

Additional 1-Year Warranty

You can extend your 1-year warranty by an additional year. Log onto **www.etekcity.com/warranty** and enter your order number (e.g., from Amazon or Houzz) within the first 14 days of your purchase to register your new product for the extended warranty.

If you are unable to provide the order number for your product, please type a short note in the order number field along with the date you received your product.

Defective Products & Returns

Should your product prove defective within the specified warranty period, please contact Customer Support via **support@etekcity.com** with your invoice and order number. **Do not** dispose of your product before contacting us. Once our Customer Support Team has approved your request, please return the unit with a copy of your invoice and order number.

Customer Support

If you encounter any issues or have any questions regarding your new product, please contact our helpful Customer Support Team. Your satisfaction is our goal!

Customer Support

Etekcitey Corporation
1202 N. Miller St., Suite A
Anaheim, CA 92806

Toll Free: (855) 686-3835
Email: support@etekcity.com

Support Hours

Mon-Fri, 9:00 am-5:00 pm PST/PDT

* Please have your order invoice and order number ready before contacting Customer Support.

Connect with us @Etekcity





v01.00