

YURI

POWERED SUBWOOFER

Specifications

Woofers	8" Long-throw Driver
Power Output	60 Watts RMS
Input Sensitivity	100 mV
Total Harmonic Distortion	< 0.1%
Frequency Range	30Hz – 150Hz
Low-Pass Filter	40 Hz - 180 Hz
Phase Switch	0° and 180°
Inputs	1 x RCA Mono Line Level
Input Voltage / Frequency	110-120VAC-60Hz 220-240VAC-50Hz (manually switching)
Standby Power Consumption	< 0.5 W
Dimensions	W 10.6" x H 10.6" x D 13.8" (27 x 31 x 35 cm)
Net Weight	21.6 lbs (9.8 kg)
Gross Weight	24.2 lbs (11 kg)

Important Safety Precautions



ATTENTION

The exclamation point within an equilateral triangle is intended to alert the user of the presence of important operating and maintenance (servicing) instructions in the literature accompanying the apparatus.



CAUTION: TO REDUCE THE RISK OF ELECTRIC SHOCK, DO NOT REMOVE BACK PANEL. NO USER SERVICEABLE PARTS INSIDE. REFER SERVICING TO QUALIFIED SERVICE PERSONNEL.



DANGEROUS VOLTAGE

The lightning flash with arrowhead, within an equilateral triangle, is intended to alert the user of the presence of non-insulated "dangerous voltage" within the product's enclosure that may be of sufficient magnitude to constitute a risk of electric shock to persons.

- Read these instructions.
- Keep these instructions.
- Heed all warnings.
- Follow all instructions.
- Do not use this apparatus near water.
- Clean only with dry cloth.
- Do not block any ventilation openings. Install in accordance with the manufacturer's instructions.
- Do not install near any heat sources such as radiators, heat registers, stoves, or other apparatus (including amplifiers) that produce heat.
- Do not defeat the safety purpose of the polarized or grounding-type plug. A polarized plug has two blades with one wider than the other. A grounding type plug has two blades and a third grounding prong. The wide blade or the third prong are provided for your safety. If the provided plug does not fit into your outlet, consult an electrician for replacement of the obsolete outlet.
- Protect the power cord from being walked on or pinched particularly at plugs, convenience receptacles, and the point where they exit from the apparatus.
- Only use attachments/accessories specified by the manufacturer.

- Use only with the cart, stand, tripod, bracket, or table specified by the manufacturer, or sold with the apparatus. When a cart is used, use caution when moving the cart/apparatus combination to avoid injury from tip-over.
- Unplug this apparatus during lightning storms or when unused for long periods of time.
- Refer all servicing to qualified service personnel. Servicing is required when the apparatus has been damaged in any way, such as power-supply cord or plug is damaged, liquid has been spilled or objects have fallen into the apparatus, the apparatus has been exposed to rain or moisture, does not operate normally, or has been dropped.
- Do not open the equipment to reduce the risk of electrical shock
- Do not expose the apparatus to rain or moisture. Do not expose the apparatus to dripping or splashing. Do not place objects filled with liquid, such as vases, on the apparatus.
- The appliance coupler is used as the disconnect device and shall remain readily operable.



FCC Warnings

- Changes or modifications not expressly approved by the party responsible for compliance could void the user's authority to operate the equipment.
- This equipment has been tested and found to comply with the limits for a Class B digital device, pursuant to Part 15 of the FCC Rules.

FCC Notice:

- This device complies with part 15 of the FCC Rules. Operation is subject to the following two conditions: (1) This device may not cause harmful interference, and (2) this device must accept any interference received, including interference that may cause undesired operation.

Industry Canada Notice:

- Complies with CAN ICES-3(B) / NMB-3(B)

Introduction

Thank you for choosing the YURI powered subwoofer. YURI was designed to augment the bass performance of your speakers in a stereo setup or in a home theater installation.

Adding a subwoofer to your system extends the bass response produced by your existing speakers and improves their midrange clarity. In a home theater application, the subwoofer takes care of reproducing signals from the low frequency channel. In a stereo system, the subwoofer helps reduce the low-frequency demands on the main speakers.

We recommend you read all instructions carefully before using the YURI and keep them for future reference. Kanto cannot be liable for damage or injury caused by incorrect setup or use of this product.

This powered subwoofer was carefully tested and inspected during production, and before packaging and shipping. After unpacking, please check for any damage. It is rare that a unit is damaged during shipping, but if this happens contact your retailer immediately. You can also call Kanto directly at 1-888-848-2643 or email support@kantoliving.com.

What's in the box?

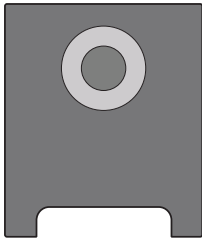

YURI
Subwoofer



Power
Cord

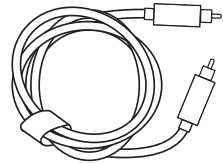

x1
RCA Cable

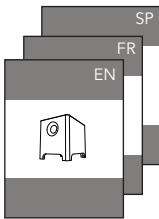

x3
User
Manuals

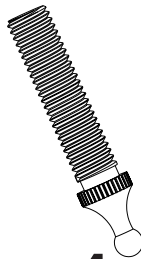

x4
Carpet Spike

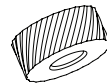

x4
Spike Nut

Front & Rear Panels

FRONT PANEL

1. 8" Paper Cone Driver
2. Flared Bass Port

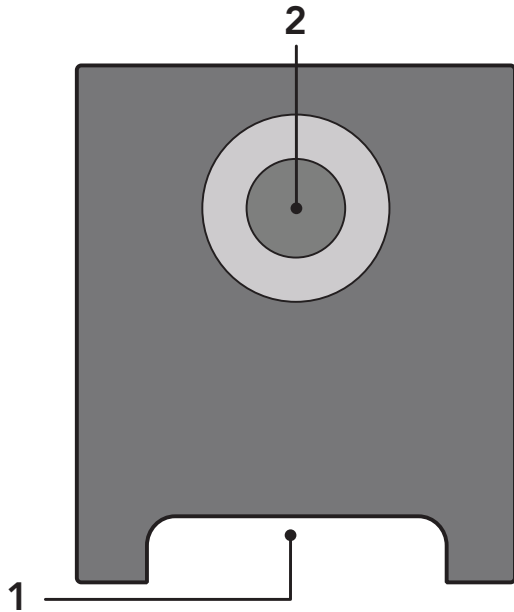

REAR PANEL

3. Volume Knob
4. Crossover Knob
5. Phase Switch
6. Standby Power
7. Line Level Input
8. ON / OFF Switch
9. AC Input Connection & Fuse (100 V - 240 V)
10. Voltage Select

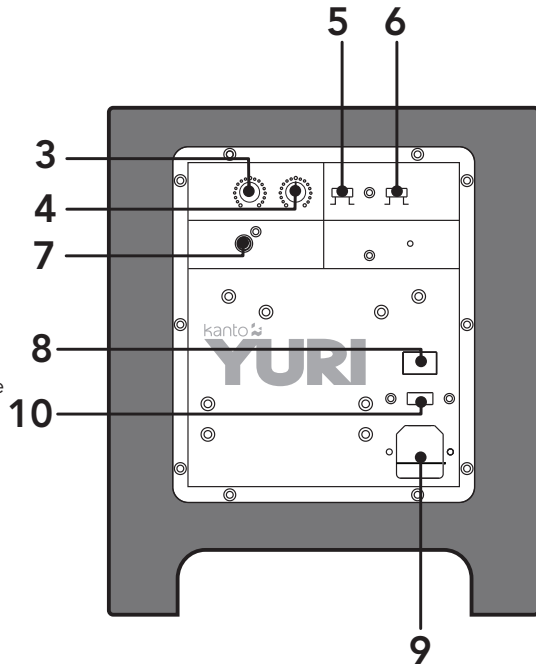

Setting up and Connecting your Subwoofer

Ensure that the ON/OFF Switch is in the OFF position before connecting any component.

In a typical application using YURI alongside additional speakers, connect your stereo component such as powered speakers (e.g. YUMI, YU2, YU3, YU5), amplifiers (e.g. YARO2), or home theater receiver to the subwoofer input on the Rear Panel. If your components are equipped with both L/R subwoofer output or L/R preamplifier outputs, you can use either channel as the output to YURI.

The Crossover Control is used to set the upper limit of the frequencies that YURI will reproduce within the range of 40Hz-180Hz. Refer to your manufacturer's information for the lower cut-off frequency of your main speakers, or adjust the Low-Pass Filter frequency to your personal preference.

The Phase Switch is normally set to 0°. If YURI is positioned significantly farther from the main speakers or if it is used in a stereo setup where the amplifier driving the main speakers inverts the phase of the signal, the 180° setting may be desirable. Listen with the switch in both positions and select the setting that gives the fullest sound. If in doubt, or if there is little difference, leave the switch set to 0°.

To some degree, positioning the subwoofer is less critical because it produces only non-directional low-frequency sounds. However, moving the YURI close to room boundaries will enhance the bass frequencies but may muddy the sound. Best results are obtained if the subwoofer is placed either between the left and right speakers or in the vicinity of either the left channel or right channel speaker. Room characteristics and positioning do have an effect on the performance of the subwoofer, so time and effort devoted to achieving the optimum position will be rewarded.

Follow the instructions below to connect your YURI Subwoofer.

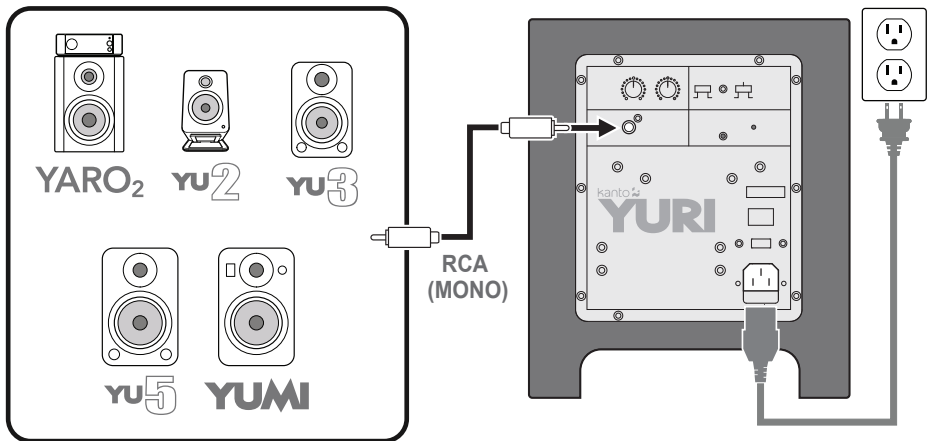

ATTENTION

When connecting audio cables the ON/OFF Switch must be turned OFF. After connecting all cables, the unit can be turned ON.

Carpet Spikes

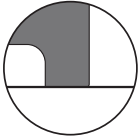

Hardwood / Tile

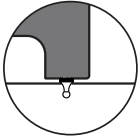

Short Carpet

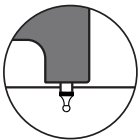

Thick Carpet

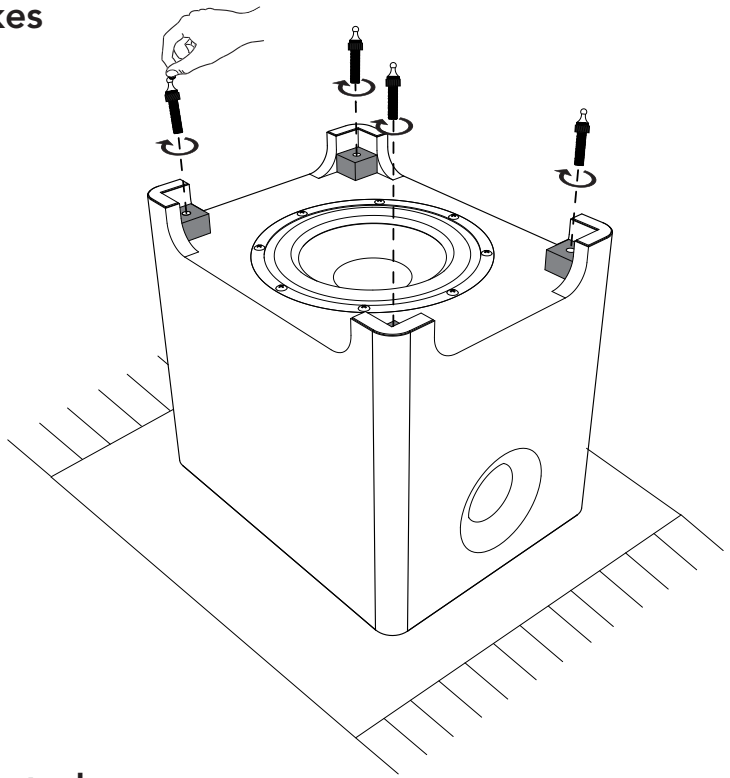

Standby Control

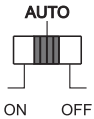

AUTO: [Recommended] When no audio signal has been detected for 10 minutes, YURI will put itself into standby mode. If the audio signal returns, it will wake up and resume playing.

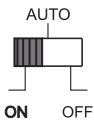

ON: By switching the standby control to "ON", YURI will not enter standby mode and will stay on indefinitely.

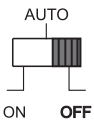

OFF: By switching the standby power to "OFF", YURI will remain in standby mode indefinitely.

Audio Troubleshooting Guide

Kanto's YURI subwoofer was carefully tested and inspected during production and it is rare that a unit is damaged during shipping. If any issues occur during the set up of your YURI subwoofer, your questions may be answered in the Troubleshooting guide below.

- 1. None of the lights on the rear panel are illuminated.**
 - Make sure the power cable is connected to the subwoofer and power outlet.
 - Ensure that the power outlet is providing power.
 - Verify that the power switch (8) on the rear of the subwoofer is in the "On" position and Standby Power switch (6) is in the "On" position.
 - You can switch it back to "Auto" after verifying normal operation.
- 2. The green light on the rear of the subwoofer is illuminated but there's no audio playing.**
 - Ensure the audio source is playing audio.
 - Check that the audio cable connected to and from the source is firmly connected. Test another audio cable if available.
 - Verify that the volume of the subwoofer is not at its minimum level.
- 3. There's no audio coming from the subwoofer.**
 - Check that the RCA cable connected to and from the subwoofer is firmly seated. Try a different cable or source to isolate the issue.
 - Make sure the subwoofer is connected to a power outlet and is set to "On" or "Auto".
 - Increase the volume of the subwoofer.
- 4. You are experiencing poor audio quality.**
 - Set the volume of the source to its highest level and reduce the volume of the subwoofer. Low source volume can negatively affect dynamic range.
 - Test a different song or source to isolate the issue.
 - Adjust crossover to match the rest of the system.
- 5. You are experiencing Buzzing, Hissing or Distortion.**
 - Ensure you are using an RCA to RCA subwoofer cable.
 - Verify if the noise is coming from the source by removing all sources from the subwoofer.
 - Make sure it is not a power issue by trying a power outlet that is on a different circuit.
 - Check that the audio cable connected to and from the source is firmly seated. Try a different cable or source to isolate the issue.
- 6. Subwoofer is going into standby while listening to audio.**
 - Set the volume of the source to its highest level. Low source volume can inadvertently trigger standby mode.

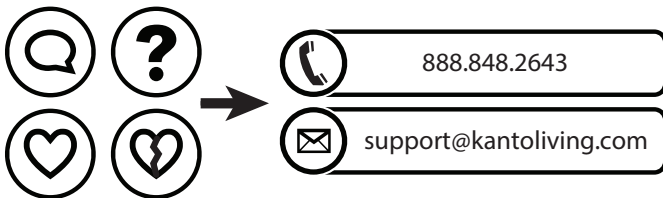

Check out more great products from Kanto!

Kanto Speakers

- Check out our full line of bookshelf and desktop speaker systems
- Available in a stunning array of colors
- Visit kantospeakers.com for more!

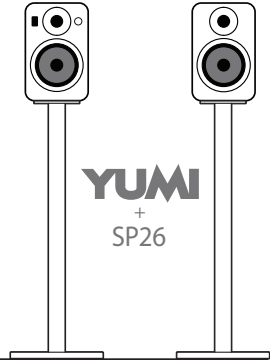

link
by kanto

- Full line of Audio and Video Cables
- White or Black Cables available
- HDMI, Optical, Mini-jack, RCA, USB
- Switchers, Hubs, and Adapters
- Visit kantoliving.com



To learn more about all our products, visit www.kantoliving.com

f Kanto Living

t @kantoliving

ig kantoliving

Warranty

Limited Warranty To Original Purchaser

Kanto Distribution Inc. (Kanto) warrants the equipment it manufactures to be free from defects in material and workmanship for the following limited warranty period of 24 months for parts and labour.

If equipment fails because of such defects and Kanto or an authorized dealer is notified within 24 months from the date of shipment with proof of original invoice. Kanto will, at its option, repair or replace the equipment, provided that the equipment has not been subjected to mechanical, electrical, or other abuse or modifications. Equipment that fails under conditions other than those covered will be repaired at the current price of parts and labor in effect at the repair. Such repairs are warranted for 90 days from the day of reshipment to the original purchaser. This warranty is in lieu of all other warranties expressed or implied, including without limitation, any implied warranty or merchantability or fitness for any particular purpose, all of which are expressly disclaimed.

Customers will be responsible for obtaining a Return Authorization as well as shipping costs to return product to a Kanto location or authorized depot listed on the website. If the equipment is covered under the warranty provisions above, Kanto will repair or replace, and be responsible for return shipping to the customer. Please keep the original packaging so products will not be damaged during shipping, and we recommend you insure your shipment. If equipment fails outside the warranty provisions, customers will be quoted repair and return shipping costs prior to work being performed.

The information in the owner's manual has been carefully checked and is believed to be accurate. However, Kanto assumes no responsibility for any inaccuracies that may be contained in the manual. In no event will Kanto, be liable for direct, indirect, special, incidental, or consequential damages resulting from any defect or omission in this manual, even if advised of the possibility of such damages.

kanto

www.kantoliving.com | support@kantoliving.com
Tel 888.848.2643

15-K