

ProXChange™ Repair Kit



IMPORTANT SAFETY INSTRUCTIONS

For detailed sprayer information and warnings, see the Owners Manual included with your sprayer.

Pressure Relief Procedure

⚠ WARNING

SKIN INJECTION HAZARD: This equipment stays pressurized until pressure is manually relieved. To help prevent serious injury from pressurized fluid, such as skin injection, splashed fluid and moving parts, follow the **Pressure Relief Procedure** whenever sprayer is stopped and before sprayer is cleaned or checked, and before equipment is serviced.

1. Turn ON/OFF switch to **OFF** position.
2. Unplug sprayer.
3. Engage trigger lock. Always engage the trigger lock when sprayer is stopped to prevent the gun from being triggered accidentally.
4. Turn pressure control knob to lowest setting.
5. Put drain tube into a waste pail. Turn prime/spray knob down or flip prime/spray lever away from sprayer to the PRIME position to relieve pressure.
6. Hold the gun firmly to a pail. Point gun into pail. Disengage the trigger lock and trigger the gun to relieve pressure.
7. Engage the trigger lock.

Disassembly

Always perform **Pressure Relief Procedure** before starting any pump repairs.

1. On sprayers with a hopper the hopper must be removed before pump can be removed. Remove airless hose, if necessary remove suction tube.
2. Pull tabs on sides of the easy access door towards you.
3. Slide door away from the inlet end of the pump.
4. Now lift the easy access door so that it swivels out of the way.

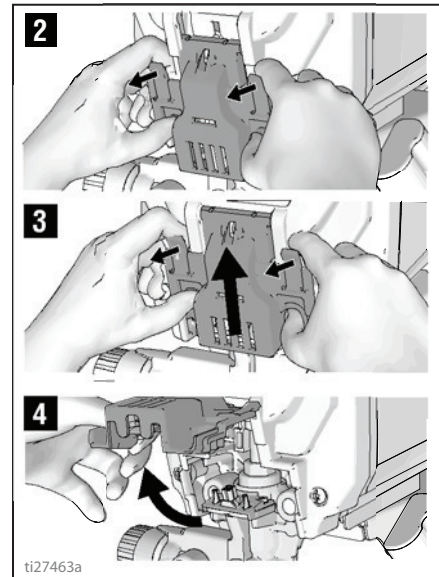

5. Insert hex end of pump into hex tool in the sprayer frame and turn counter-clockwise to loosen assembly. Location of the hex varies depending on the sprayer.

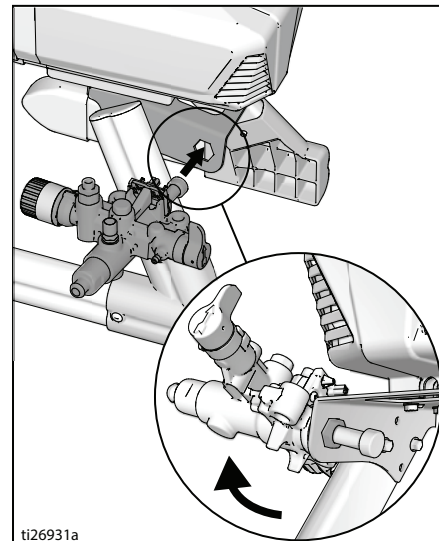

6. Slide pump assembly off the mounting pins.
7. Remove entire packing assembly from pump housing including the packing spring.

Assembly

1. On the new pump remove protective cap from the end of the piston rod.

NOTICE

Be careful not to lose the packing spring that is installed on the pump rod. Operation without the packing spring will cause early pump failure.

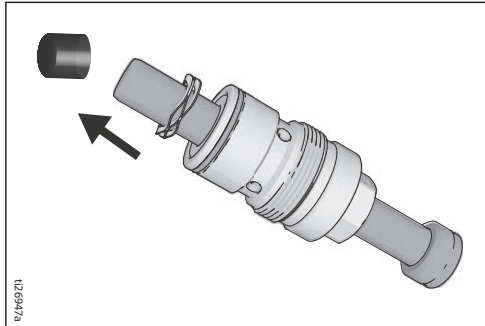

2. While holding the pump body upside down start threading the new packing assembly in by hand.

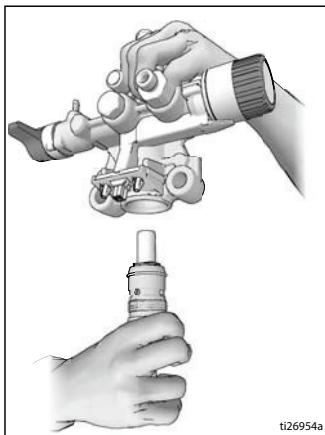

3. Insert hex end of pump into hex tool in the sprayer frame and tighten. Recommended torque is 300 in.lb (35 N•m).
4. Slide pump assembly onto the mounting pins.
 - a. Move pump rod up or down until cap is level with the opening in the yoke.

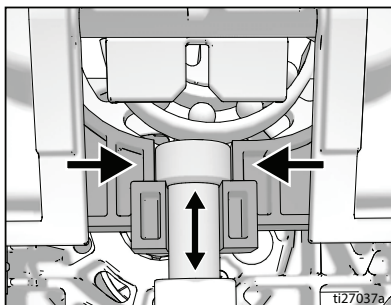

- b. Push on pump rod to slide pump assembly back on to mounting pins.

5. Swing easy access door closed while pushing the entire door towards the inlet end of the pump.

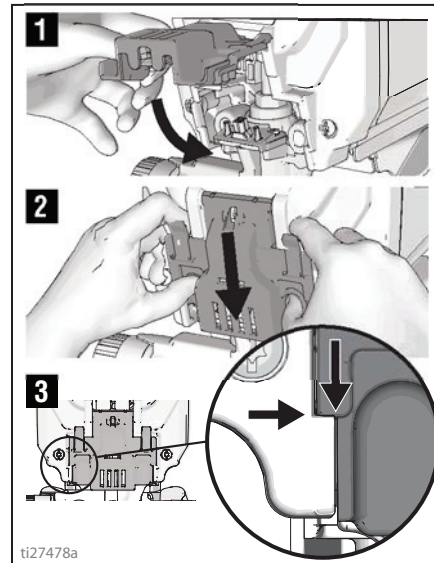

6. Install hopper if it was removed and any hoses removed earlier.
7. Plug sprayer into power source.

NOTE: Door must be fully closed and latched before sprayer will operate.

When pump packings wear, paint will begin to leak down outside of pump. Each time the pump kit is replaced, check pump inlet and outlet valves for wear or damage. Replace if worn or damaged. Always replace inlet and outlet valves every second time the pump kit is replaced.

Simple repair doubles the pump life. See instructions inside.

For use with Magnum® Pro Sprayers (except 261815, 261820, 24N906, 24N808) and Graco GX™ Sprayers.

Reparación simple duplica la vida de la bomba. Vea las instrucciones en el interior.

Para el uso con Magnum® Pro Pulverizadores (excepto 261815, 261820, 24N906, 24N808) y Graco GX™ pulverizadores.

All written and visual data contained in this document reflects the latest product information available at the time of publication.

Graco reserves the right to make changes at any time without notice.

For patent information, see www.graco.com/patents.

Original instructions. This manual contains English. MM 3A3172

Graco Headquarters: Minneapolis,
International Offices: Belgium,
China, Japan, Korea

GRACO INC. AND SUBSIDIARIES
• P.O. BOX 1441 • MINNEAPOLIS
MN 55440-1441 • USA

Copyright 2015, Graco Inc. All
Graco manufacturing locations
are registered to ISO 9001.

www.graco.com

Revision B - February 2016



graco.com/proxchange

Place
UPC Code
Here

Blue is a trademark of Graco Inc. for Contractor Equipment Sprayers. Blue es una marca comercial de Graco Inc. para los Pulverizadores Contractor.