

# 深圳市阿美林电子科技有限公司

Shenzhen Amelin Electronic Technology Co., Ltd

# Specification

TFT-LCD module

<b>Module</b> (型号):	<b>AML130A2402A</b>
<b>Customer</b> (客户):	
<b>Customer P/N</b> (客户型号):	

If there is no special request from customer, Amelin will not reserve the tooling of the product under the following conditions:

1. There is no response from customer in one years after Amelin submit The samples;
2. There is no order in one years after the latest mass production. And correlated data (include quality record) will be reserved one year more after tooling was discarded.

<b>Approved by (批准):</b>	
<b>Qualified (合格):</b>	<b>Unqualified (不合格):</b>

<b>PREPARED</b>	<b>CHECKED</b>	<b>APPROVED</b>

-----

-----



## ***TABLE OF CONTENT***

- GENERAL SPECIFICATIONS
- ABSOLUTE MAXIMUM RATINGS
- ELECTRICAL CHARACTERISTICS
- BACKLIGHT CHARACTERISTICS
- DIMENSIONAL DRAWING
- INTERFACE PIN CONNECTIONS
- ELECTRO-OPTICAL CHARACTERISTICS
- INSPECTION CRITERIA
- RELIABILITY
- PRECAUTIONS FOR USING LCD MODULE
- USING LCD MODULES

## 1.0 General Specifications

**AML130A2402A** is a color active matrix LCD module incorporating amorphous silicon **TFT** (Thin Film Transistor). It is composed of a color TFT-LCD panel, driver IC, FPC and a back light unit. The module display area contains **240x 240** pixels and can display up to **262K** colors. This product accords with RoHS environmental criterion.

<b>Item</b>	<b>Contents</b>	<b>Unit</b>
LCD Type	TFT TRANSMISSIVE	/
Viewing direction	FULL VIEW	/
Module outline (W x HxD)	35.5*38.23*1.4	mm
Active area (WxH)	32.34*32.34	mm
Number of Dots	240(RGB) x240	/
Driver IC	ST7789V	/
Colors	262K	/
Backlight Type	LED	/
Interface Type	System Serial interface	/
Input voltage	2.8	V

## 2.0 ABSOLUTE MAXIMUM RATINGS

<i>Parameter</i>	<i>Symbol</i>	<i>Min</i>	<i>Max</i>	<i>Unit</i>
Supply voltage for logic	Vcc1,Vcc2	-0.3	4.6	V
Input voltage	Vin	0.5	VCC+ 0.5	V
Operating temperatur	Top	-20	60	°C
Storage temperature	Tst	-30	70	°C
Humidity	RH	--	90%(Max60C)	RH

## 3.0 ELECTRICAL CHARACTERISTICS

<i>Parameter</i>	<i>Symbol</i>	<i>Min</i>	<i>Typ</i>	<i>Max</i>	<i>Unit</i>
Supply voltage for logic	Vcc -Vss	2.4	2.8	3.2	V
I/O power supply	IOVCC	1.65	1.8	3.2	V
Input Current	Idd	-	TBD	TBD	mA
Input voltage ' H ' level	Vih	0.7IOVCC	--	IOVCC	V
Input voltage ' L ' level	Vil	GND	0	0.3IOVCC	V
Output voltage ' H ' level	Voh	0.8IOVCC	--	IOVCC	V
Output voltage ' L ' level	Vol	GND	0	0.2IOVCC	V

## 4.0 BACKLIGHT CHARACTERISTICS

<i>Item</i>	<i>Symbol</i>	<i>Min</i>	<i>Typ</i>	<i>Max</i>	<i>Unit</i>	<i>Condition</i>
Forward voltage	Vf	6	6.2	6.4	V	--
Luminance	Lv	3500	3800	4200	cd/m2	If=15MA
Number of LED	--	2			Piece	--
Connection mode	S	Serial			--	--

Using condition: constant current driving method If= 15mA(+/-10%)

版本	变更日期	变更内容	批准

A

A

B

B

C

C

D

D

E

E

PIN	NAME
1	LEDK
2	LEDK
3	GND
4	GND
5	FMARK
6	SDA
7	WR
8	SCL
9	CS
10	RESET
11	IOVCC18
12	IOVCC18
13	VCC2B
14	VCC2B
15	GND
16	GND
17	NC
18	NC
19	NC
20	NC
21	NC
22	NC
23	LEDA
24	LEDA

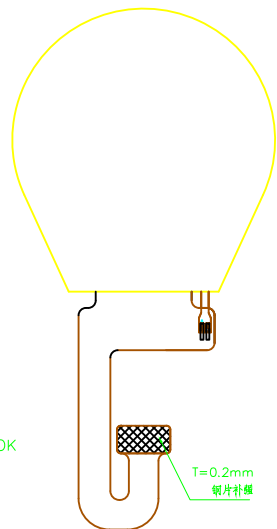
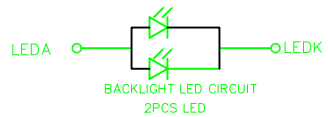
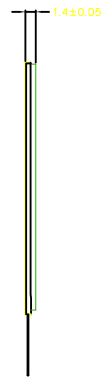
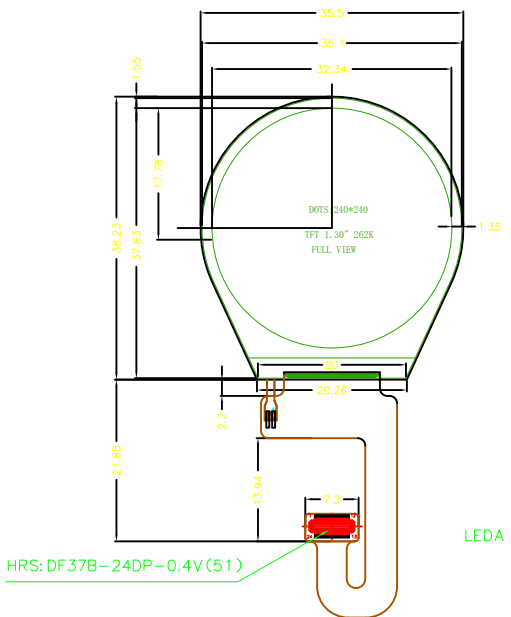

HRS: DF 37B-24DP-0.4V (51)

1. DISPLAY TYPE	1.54" TFT, TRANSMISIVE	Approve
2. VIEWING DIRECTION	ALL VIEW	Checked
3. DRIVER IC	ST7789V	
4. BACKLIGHT	2 Chip-White LED, Serial	Drawn
5. OPERATIVE VOLTAGE	2.8V	
6. OPERATIVE TEMP.	-10° C TO 60° C	Approved
7. STORAGE TEMP.	-20° C TO 70° C	
8. CONNECTOR	FPC	

深圳市阿美林电子科技有限公司  
Shenzhen Amelin Electronic Technology Co., Ltd

Dwg.No AML130A2402A

Unmarked Tolerance	±0.2
Unit	mm
Scale	
Date	2010/8/12
Page	1/1

1

2

3

4

5

6

7

## 6.0 INTERFACE PIN CONNECTIONS

<b>Pin.No</b>	<b>Symbol</b>	<b>Function</b>
1	LEDK	back light power supply negative
2	LEDK	back light power supply negative
3	GND	Ground
4	GND	Ground
5	FMARK	Tearing effect signal is used to synchronize MCU to frame memory writing
6	SDA	Serial data input pin
7	WR	Second Data lane in 2 data lane serial interface
8	SCL	Serial clock input pin
9	CS	chip select signal input
10	RESET	A reset pin
11	IOVCC18	power supply (1.8/+2.8)
12	IOVCC18	power supply (1.8/+2.8)
13	VCC28	Power supply (+2.8)
14	VCC28	Power supply (+2.8)
15	GND	Ground
16	GND	Ground
17	NC	No connect
18	NC	No connect
19	NC	No connect
20	NC	No connect
21	NC	No connect
22	NC	No connect
23	LEDA	Back light power supply positive
24	LEDA	Back light power supply positive

## 6. 1 TIMING CHARACTERISTICS

### 6.1.1 Serial interface characteristics (4-line serial)

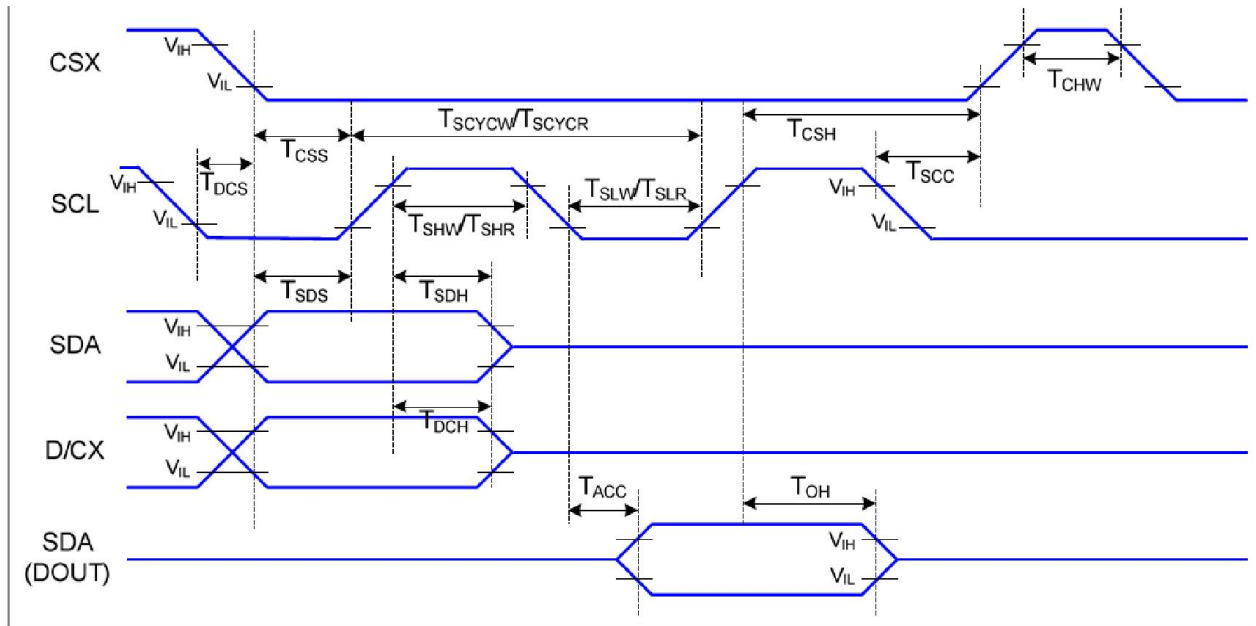

Figure 8.4.1 4-line serial interface timing

Signal	Symbol	Parameter	MIN	MAX	Unit	Description
CSX	T <sub>CSS</sub>	Chip select setup time (write)	45		ns	
	T <sub>CSH</sub>	Chip select hold time (write)	45		ns	
	T <sub>CSS</sub>	Chip select setup time (read)	60		ns	
	T <sub>SCC</sub>	Chip select hold time (read)	65		ns	
	T <sub>CHW</sub>	Chip select "H" pulse width	40		ns	
SCL	T <sub>SCYC</sub> W	Serial clock cycle (Write)	66		ns	-write command & data ram
	T <sub>SHW</sub>	SCL "H" pulse width (Write)	15		ns	
	T <sub>SLW</sub>	SCL "L" pulse width (Write)	15		ns	
	T <sub>SCYC</sub> R	Serial clock cycle (Read)	150		ns	-read command & data ram
	T <sub>SHR</sub>	SCL "H" pulse width (Read)	60		ns	
	T <sub>SLR</sub>	SCL "L" pulse width (Read)	60		ns	
D/CX	T <sub>DCS</sub>	D/CX setup time	10		ns	
	T <sub>DCH</sub>	D/CX hold time	10		ns	
SDA (DIN) (DOUT)	T <sub>SDS</sub>	Data setup time	10		ns	For maximum CL=30pF For minimum CL=8pF
	T <sub>SDH</sub>	Data hold time	10		ns	
	T <sub>ACC</sub>	Access time	10	50	ns	
	T <sub>OH</sub>	Output disable time	15	50	ns	

Table 8.4.1 4-line Serial Interface Characteristics



## 6.2. Reset Input Timing

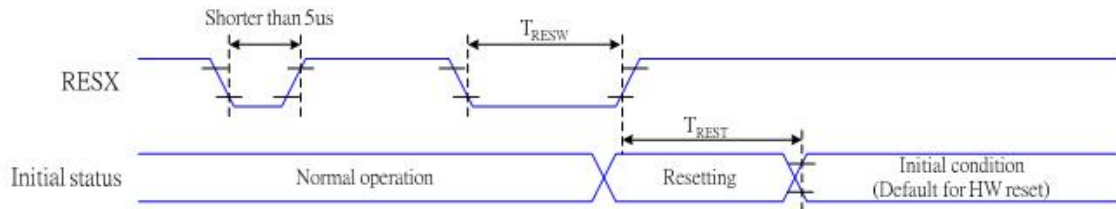

Table 9.16.1 Reset timing

Related Pins	Symbol	Parameter	MIN	MAX	Unit
RESX	$t_{RESW}$	Reset pulse duration	10	-	us
	$t_{REST}$	Reset cancel	-	5	ms
				120	ms

Notes:

1. The reset cancel includes also required time for loading ID bytes, VCOM setting and other settings from EEPROM (or similar device) to registers. This loading is done every time when there is HW reset cancel time ( $t_{RT}$ ) within 5 ms after a rising edge of RESX.
2. Spike due to an electrostatic discharge on RESX line does not cause irregular system reset according to the table below:

RESX Pulse	Action
Shorter than 5us	Reset Rejected
Longer than 9us	Reset
Between 5us and 9us	Reset starts

3. During the Resetting period, the display will be blanked (The display is entering blanking sequence, which maximum time is 120 ms, when Reset Starts in Sleep Out -mode. The display remains the blank state in Sleep In -mode.) and then return to Default condition for Hardware Reset.

4. Spike Rejection also applies during a valid reset pulse as shown below:

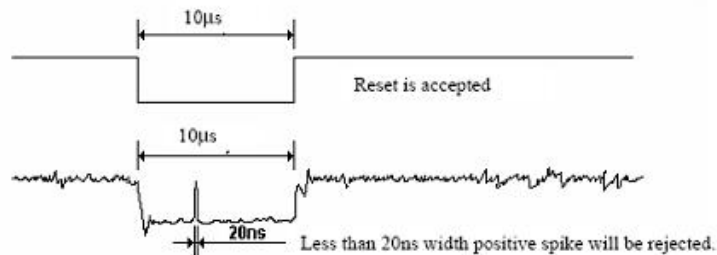

5. When Reset applied during Sleep In Mode.
6. When Reset applied during Sleep Out Mode.
7. It is necessary to wait 5msec after releasing RESX before sending commands. Also Sleep Out command cannot be sent for 120msec.

### 6.3 BLOCK DIAGRAM OF LCM

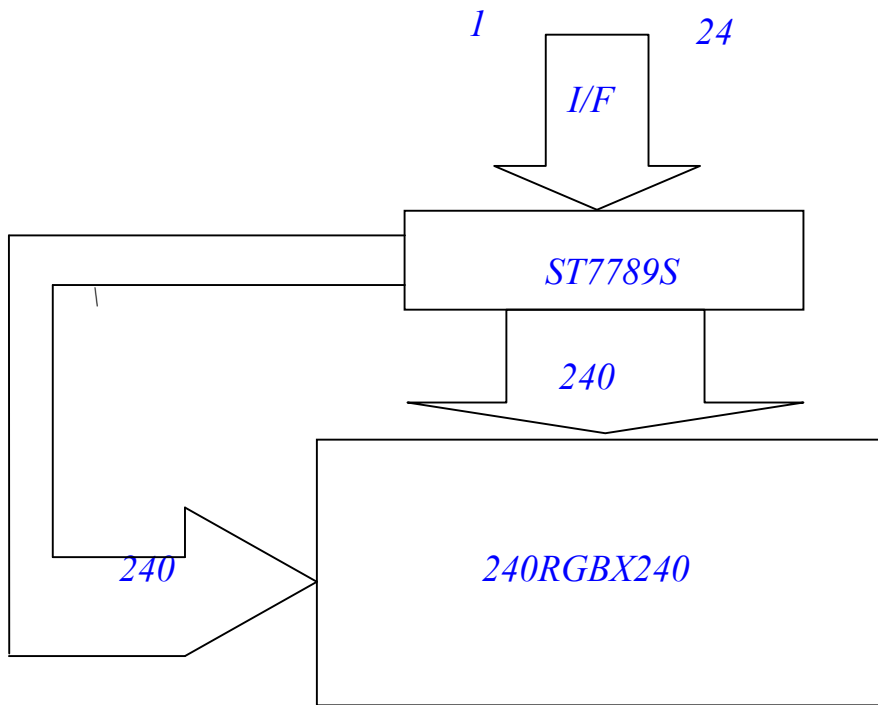

## 7. ELECTRO-OPTICAL CHARACTERISTICS

<i>Item</i>	<i>Symbol</i>	<i>Condition</i>	<i>Temp</i>	<i>Min</i>	<i>Typ</i>	<i>Max</i>	<i>Units</i>	<i>Note</i>
<i>Operating Volt.</i>	<i>V<sub>LCD</sub></i>	$\theta = \psi = 0$	-10 °C	----	----	----	<i>V</i>	8.1
			25 °C	----	8.5	----		
			60 °C	----	----	----		
<i>Response Time</i>	<i>Rise Time (Tr)</i>	$\theta = \psi = 0$	-10 °C	----	----	----	<i>msec</i>	8.2
	<i>Decay Time (Td)</i>			----	----	----		
	<i>Rise Time (Tr)</i>		25 °C	----	----	240		
	<i>Decay Time (Td)</i>			----	----	240		
	<i>Rise Time (Tr)</i>		60 °C	----	----	----		
	<i>Decay Time (Td)</i>			----	----	----		
<i>Viewing Angle Range</i>	$\theta$	$\psi = 0^\circ$	25 °C	----	----	30	<i>Deg</i>	8.3 $CR \geq 2$
		$\psi = 90^\circ$		----	----	30		
		$\psi = 180^\circ$		----	----	30		
		$\psi = 270^\circ$		----	----	30		
<i>Contrast Ratio</i>	<i>Cr</i>	$\theta = \psi = 0$	25 °C	3	4.5	----	---	8.4

## 7.1 ELECTRO-OPTICAL CHARACTERISTICS TEST METHOD

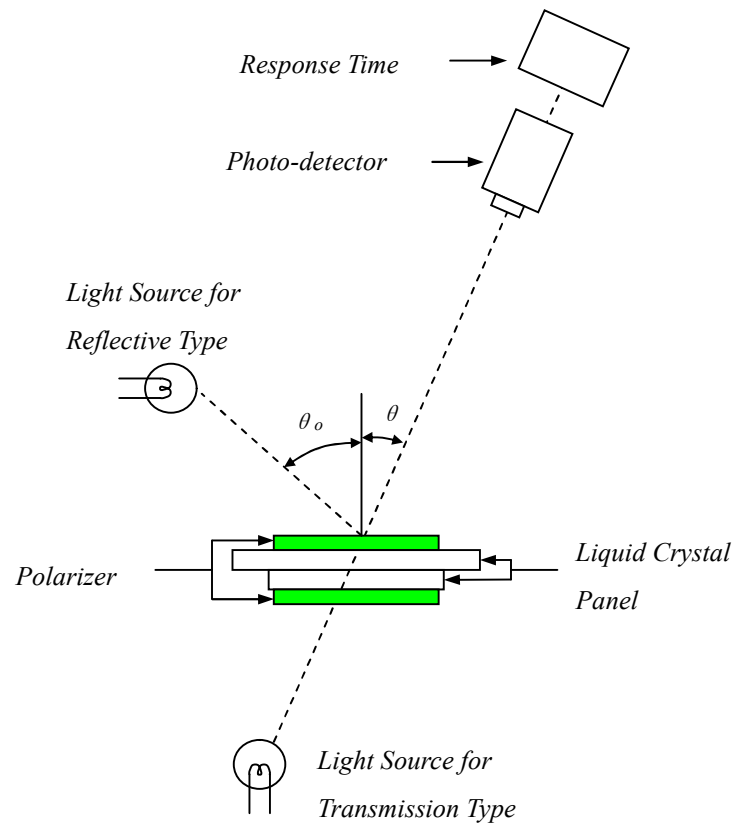

## 7.2 DEFINITION OF OPERATING VOLTAGE, VOP

$$V_{op} = (V_{10,ON} + V_{90,OFF})/2$$

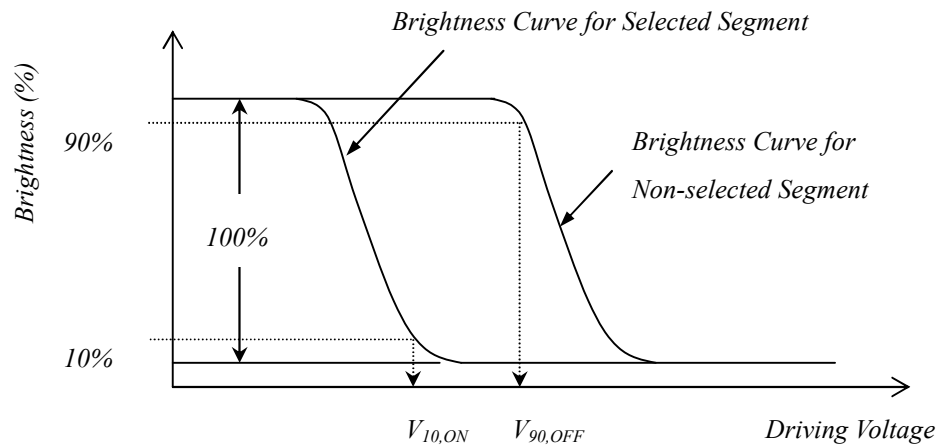

## 7.3 DEFINITION OF OPTICAL RESPONSE TIME

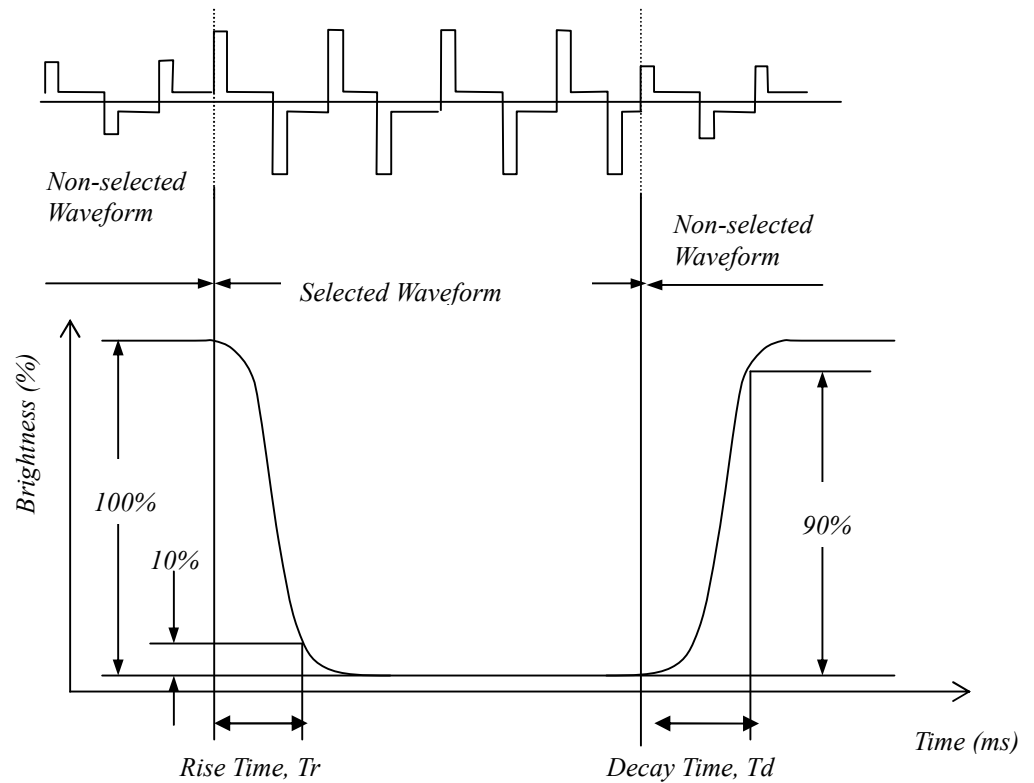

## 7.4 DEFINITION OF VIEWING ANGLE $\theta$ AND $\phi$

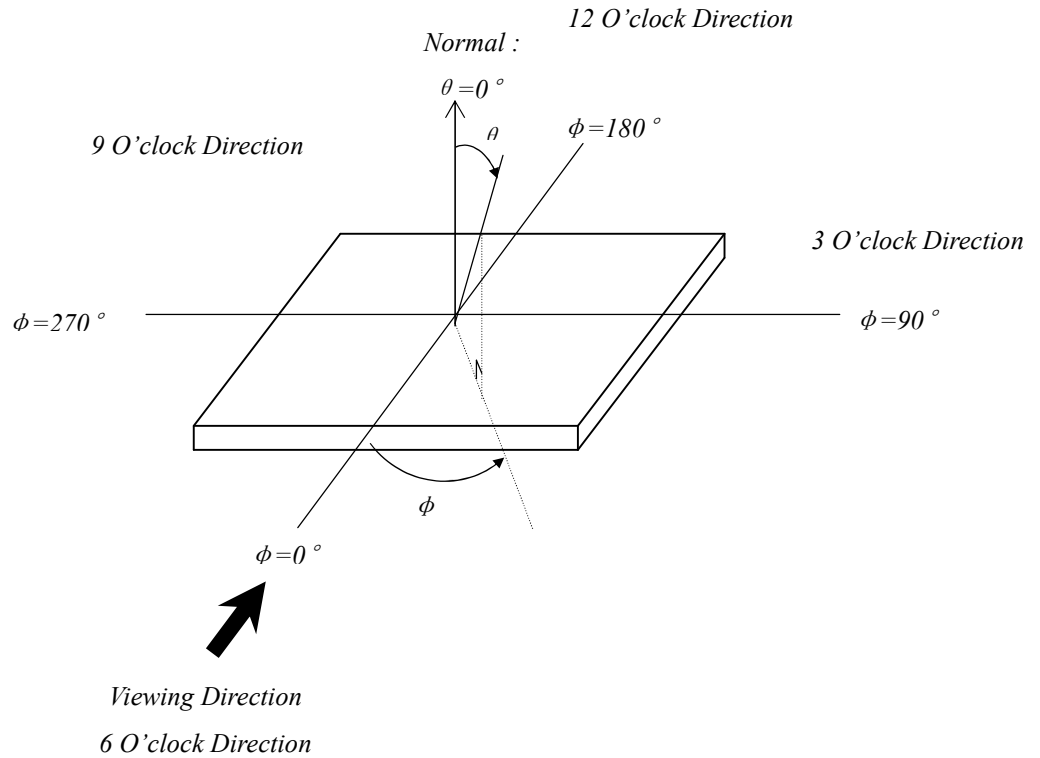

## 7.5 DEFINITION OF CONTRAST RATIO, CR

$$CR = \frac{\text{Brightness of Non-selected Segment (B2)}}{\text{Brightness of Selected Segment (B1)}}$$

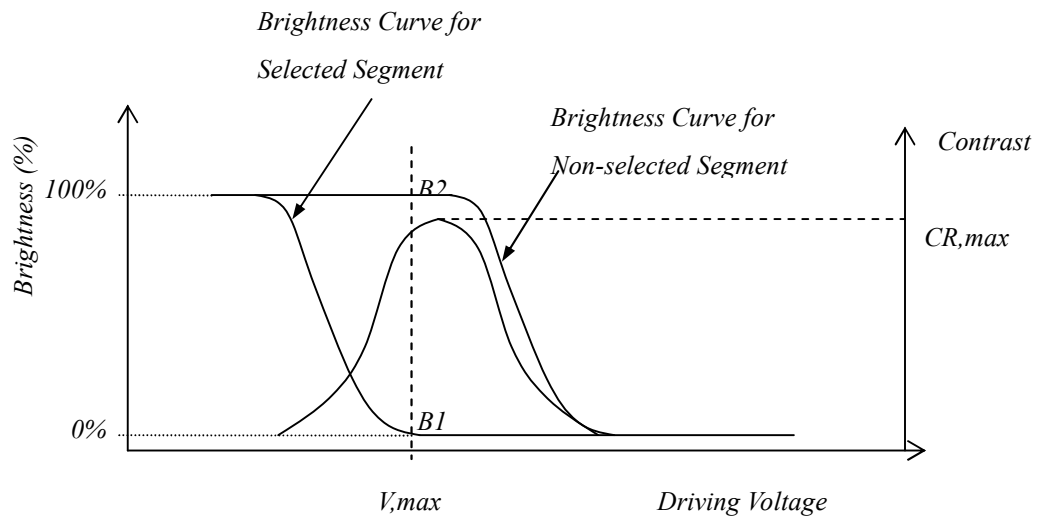

## **8.INSPECTION CRITERIA**

### **8.1Inspection Conditions**

#### *8.1.1Environmental conditions*

*The environmental conditions for inspection shall be as follows*

*Room temperature:  $20\pm 3^{\circ}\text{C}$*

*Humidity:  $65\pm 20\%RH$*

#### *8.1.2 The external visual inspection*

*With a single 20-watt fluorescent lamp as the light source, the inspection was in the distance of 30cm or more from the LCD to the inspector's eyes .*

### **8.2 LIGHT METHOD**

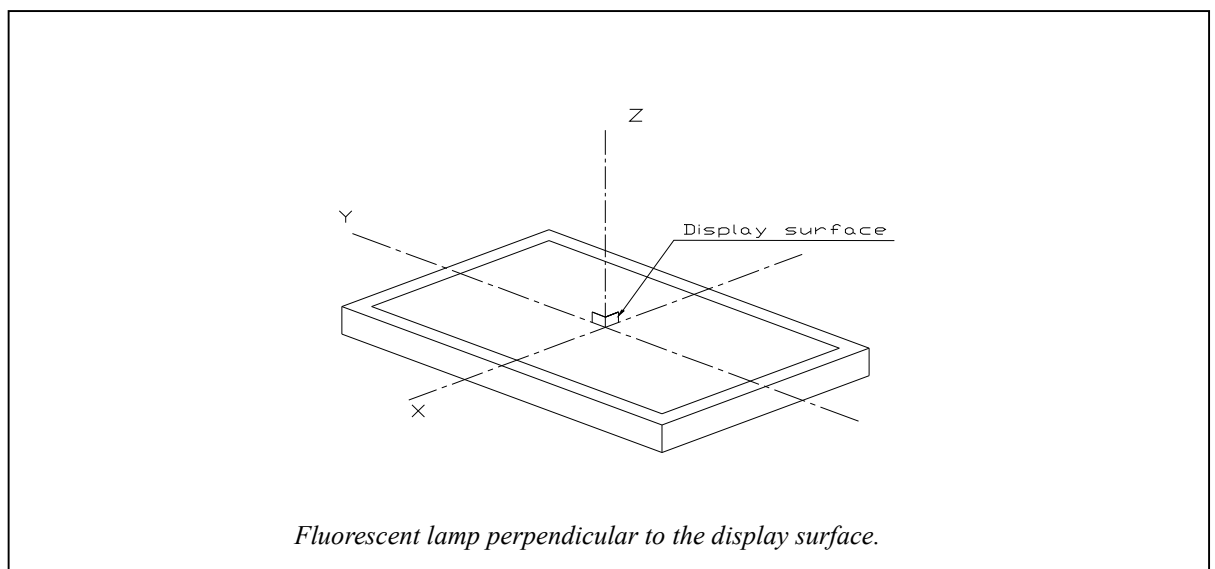

### *Inspection distance and angle*

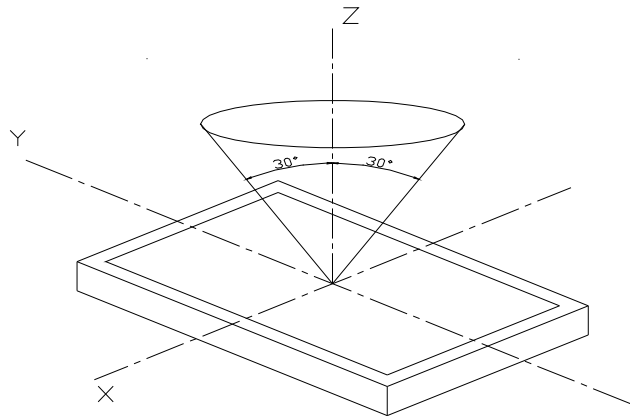

*Inspection should be performed within angle  $\phi$  ( $\phi$  is usually  $30^\circ$ ) from Z axis to each X and Y.*

*Inspection distance in any direction within  $\phi$  must be kept  $30 \pm 5$  cm from the display surface.*

## **8.3 Classification of defects**

### *9.3.1 Major defect*

*A major defect refers to a defect that may substantially degrade usability for product applications.*

### *9.3.2 Minor defect*

*A minor defect refers to a defect which is not considered to be able substantially degrade the product application or a defect that deviates from existing standards almost unrelated to the effective use of the product or its operation.*



## 9. RELIABILITY

### 9.1 MTBF

The LCD module shall be designed to meet a minimum MTBF value of 50000 hours with normal. (25°C in the room without sunlight)

### 9.2 TESTS

NO.	Test Item	Test condition	Criterion
1	High Temperature Storage	80°C±2°C 96H Restore 2H at 25°C Power off	After testing, cosmetic and electrical defects should not happen.
2	Low Temperature Storage	-30°C±2°C 96H Restore 2H at 25°C Power off	
3	High Temperature Operation	70°C±2°C 96H Restore 2H at 25°C Power on	
4	Low Temperature Operation	-20°C±2°C 96H Restore 4H at 25°C Power on	
5	High Temperature & Humidity Operation	60°C±2°C 90%RH 96H Power on	
6	Temperature Cycle	-30°C ↔ 25°C ↔ 80°C 30min 5min 30min after 10cycle, Restore 2H at 25°C Power off	
7	Vibration Test	10Hz~150Hz, 100m/s <sup>2</sup> , 120min	
8	Shock Test	Half-sinewave, 300m/s <sup>2</sup> , 11ms	
9	Drop Test(package state)	800mm, concrete floor, 1corner, 3edges, 6 sides each time	1.After testing, cosmetic and electrical defects should not happen. 2.the product should remain at initial place 3.Product uncovered or package broken is not permitted.

## 10. PRECAUTIONS FOR USING LCD MODULE

### 10.1 handling precautions

- (1) *The display panel is made of glass. Do not subject it to a mechanical shock or impact by dropping it.*
- (2) *If the display panel is damaged and the liquid crystal substance leaks out, be sure not to get any in your mouth. If the substance contacts your skin or clothes, wash it off using soap and water.*
- (3) *Do not apply excessive force to the display surface or the adjoining areas since this may cause the color tone to vary.*
- (4) *The polarizer covering the display surface of the LCD module is soft and easily scratched. Handle this polarizer carefully.*
- (5) *If the display surface becomes contaminated, breathe on the surface and gently wipe it with a soft dry cloth. If it is heavily contaminated, moisten a cloth with one of the following solvents:
  - Isopropyl alcohol
  - Ethyl alcohol*
- (6) *Solvents other than those above mentioned may damage the polarizer. Especially, do not use the following:
  - Water
  - Ketone
  - Aromatic solvents*
- (7) *Extra care to minimize corrosion of the electrode. Water droplets, moisture condensation or a current flow in a high-humidity environment accelerates corrosion of the electrode.*
- (8) *Install the LCD Module by using the mounting holes. When mounting the LCD Module, make sure it is free of twisting, warping and distortion. In particular, do not forcibly pull or bend the I/O cable or the backlight cable.*
- (9) *Do not attempt to disassemble or process the LCD Module.*
- (10) *NC terminal should be open. Do not connect anything.*
- (11) *If the logic circuit power is off, do not apply the input signals.*
- (12) *To prevent destruction of the elements by static electricity, be careful to maintain an optimum work environment.
  - Be sure to ground the body when handling the LCD Module.
  - Tools required for assembling, such as soldering irons, must be properly grounded.
  - To reduce the amount of static electricity generated, do not conduct assembling and other*

*work under dry conditions.*

*-The LCD Module is coated with a film to protect the display surface. Exercise care when peeling off this protective film since static electricity may be generated.*

## **10.2 STORAGE PRECAUTIONS**

*When storing The LCD Module, avoid exposure to direct sunlight of fluorescent lamps. Keep the modules in bags (avoid high temperature/ high humidity and low temperatures below 0 °C). Whenever possible, the LCD Module should be stored in the same conditions in which they were shipped from our company.*

## **10.3 OTHERS**

*Liquid crystals solidify under low temperature (below the storage temperature range) leading to defective orientation or the generation of air bubbles (black or white). Air bubbles may also be generated if the module is subject to a low temperature.*

*If the LCD Module have been operating for a long time showing the same display patterns the display patterns may remain on the screen as ghost images and a slight contrast irregularity may also appear. A normal operating status can be recovered by suspending use for some time. It should be noted that this phenomenon does not adversely affect performance reliability.*

*To minimize the performance degradation of the LCD Module resulting from destruction caused by static electricity etc. exercise care to avoid holding the following sections when handling the modules.*

- Exposed area of the printed circuit board.*
- Terminal electrode sections.*

## ***.11. USING LCD MODULES***

### ***11.1 LIQUID CRYSTAL DISPLAY MODULES***

*LCD is composed of glass and polarizer. Pay attention to the following items when handling.*

- (1) Please keep the temperature within specified range for use and storage. Polarization degradation, bubble generation or polarizer peel-off may occur with high temperature and high humidity.*
- (2) Do not touch, push or rub the exposed polarizers with anything harder than a HB pencil lead (glass, tweezers, etc).*
- (3) N-hexane is recommended for cleaning the adhesives used to attach front/rear polarizers and reflectors made of organic substances, which will be damaged by chemicals such as acetone, toluene, toluene, ethanol and isopropyl alcohol.*
- (4) When the display surface becomes dusty, wipe gently with absorbent cotton or other soft material like chamois soaked in petroleum ether. Do not scrub hard to avoid damaging the display surface.*
- (5) Wipe off saliva or water drops immediately, contact with water over a long period of time may cause deformation or color fading.*
- (6) Avoid contacting oil and fats.*
- (7) Condensation on the surface and contact with terminals due to cold will damage, stain or polarizers. After products are tested at low temperature they must be warmed up in a container before coming is contacting with room temperature air.*
- (8) Do not put or attach anything on the display area to avoid leaving marks on.*
- (9) Do not touch the display with bare hands. This will stain the display area and degrade insulation between terminals (some cosmetics are determinate to the polarizers).*
- (10)As glass is fragile, it tends to become or chipped during handling especially on the edges. Please avoid dropping or jarring.*

### ***11.2 INSTALLING LCD MODULE***

*Attend to the following items when installing the LCM.*

- (1) Cover the surface with a transparent protective plate to protect the polarizer and LC cell.*
- (2) When assembling the LCM into other equipment, the spacer to the bit between the LCM and the fitting plate should have enough height to avoid causing stress to the module surface, refer to the individual*

specifications for measurements. The measurement tolerance should be  $\pm 0.1\text{mm}$ .

### 11.3 ELECTRO-STATIC DISCHARGE CONTROL

Since this module uses a CMOS LSI, the same careful attention should be paid for electrostatic discharge as for an ordinary CMOS IC.

- (1) Make certain that you are grounded when handling LCM.
- (2) Before removing LCM from its packing case or incorporating it into a set, be sure the module and your body have the same electric potential.
- (3) When soldering the terminal of LCM, make certain the AC power source for the soldering iron does not leak.
- (4) When using an electric screwdriver to attach LCM, the screwdriver should be of ground potentiality to minimize as much as possible any transmission of electromagnetic waves produced sparks coming from the commutator of the motor.
- (5) As far as possible, make the electric potential of your work clothes and that of the workbenches to the ground potential.
- (6) To reduce the generation of static electricity, be careful that the air in the work is not too dried. A relative humidity of 50%-60% is recommended.

### 11.4 PRECAUTION FOR SOLDERING TO THE LCM

- (1) Observe the following when soldering lead wire, connector cable and etc. to the LCM.

-Soldering iron temperature:  $280 \pm 10^\circ\text{C}$ .

-Soldering time: 3-4 sec.

-Solder: eutectic solder.

If soldering flux is used, be sure to remove any remaining flux after finishing to soldering operation. (This does not apply in the case of a non-halogen type of flux.) It is recommended that you protect the LCD surface with a cover during soldering to prevent any damage due to flux spatters.

- (2) When soldering the electroluminescent panel and PC board, the panel and board should not be detached more than three times. This maximum number is determined by the temperature and time conditions mentioned above, though there may be some variance depending on the temperature of the soldering iron.
- (3) When removing the electroluminescent panel from the PC board, be sure the solder has completely melted, otherwise the soldered pad on the PC board could be damaged.

## 11.5 PRECAUTIONS FOR OPERATION

- (1) *Viewing angle varies with the change of liquid crystal driving voltage ( $V_0$ ). Adjust  $V_0$  to show the best contrast.*
- (2) *Driving the LCD in the voltage above the limit will shorten its lifetime.*
- (3) *Response time is greatly delayed at temperature below the operating temperature range. However, this does not mean the LCD will be out of the order. It will recover when it returns to the specified temperature range.*
- (4) *If the display area is pushed hard during operation, the display will become abnormal. However, it will return to normal if it is turned off and then on.*
- (5) *Condensation on terminals can cause an electrochemical reaction disrupting the terminal circuit. Therefore, it must be used under the relative condition of 40°C, 50% RH.*
- (6) *When turning the power on, input each signal after the positive/negative voltage becomes stable.*

## 11.6 STORAGE

*When storing LCDS as spares for some years, the following precaution are necessary.*

- (1) *Store them in a sealed polyethylene bag. If properly sealed, there is no need for desiccant.*
- (2) *Store them in a dark place. Do not expose to sunlight or fluorescent light, keep the temperature between 0°C and 35°C.*
- (3) *The polarizer surface should not come in contact with any other objects. (We advise you to store them in the container in which they were shipped.)*
- (4) *Environmental conditions:*
  - Do not leave them for more than 168hrs. at 60 °C.
  - Should not be left for more than 48hrs. at -20 °C.

## 11.7 SAFETY

- (1) *It is recommended to crush damaged or unnecessary LCDs into pieces and wash them off with solvents such as acetone and ethanol, which should later be burned.*

- (2) *If any liquid leaks out of a damaged glass cell and comes in contact with the hands, wash off thoroughly with soap and water.*

## **11.8 LIMITED WARRANTY**

*Unless agreed between Amelin and customer, Amelin will replace or repair any of its LCD and modules which are found to be functionally defective when inspected in accordance with Amelin acceptance standards (copies available upon request) for a period of one year from date of shipments. Cosmetic/visual defects must be returned to Amelin within 90 days of shipment. Confirmation of such date shall be based on freight documents. The warranty liability of Amelin is limited to repair and/or replacement on the terms set forth above. Amelin will not be responsible for any subsequent or consequential events.*

## **11.9. RETURN LCM UNDER WARRANTY**

*No warranty can be granted if the precautions stated above have been disregarded. The typical examples of violations are:*

- Broken LCD glass.*
- PCB eyelet's damaged or modified.*
- PCB conductors damaged.*
- Circuit modified in any way, including addition of components.*
- PCB tampered with by grinding, engraving or painting varnish.*
- Soldering to or modifying the bezel in any manner.*

*Module repairs will be invoiced to the customer upon mutual agreement. Modules must be returned with sufficient description of the failures or defects. Any connectors or cable installed by the customer must be removed completely without damaging the PCB eyelet's conductors and terminals.*