

# Maintenance sheet

ATKJ2  
62Q064-3

## A. Troubleshooting

If the error code is indicated on the Red LED (Refer to the Section C) on the PCB (Part #701) of the water heater (and/or the remote controller), refer to Section B.

### << It takes long time to get hot water at the fixtures >>

- The time it takes to deliver hot water from the water heater to your fixtures depends on the length of piping between the two. The longer the distance or the bigger the pipes, the longer it will take to get hot water.
- If you would like to receive hot water to your fixtures quicker, you may want to consider a hot water recirculation system.

### << The water is not hot enough or turns cold and stays cold >>

- Compare the flow and temperature. Refer to the "Output temperature chart" of the installation manual.
- Check cross plumbing between cold water lines and hot water lines.
- Check if the gas supply valve fully open, the gas line sized properly and the gas supplies pressure enough. Refer to the "Gas supply and gas pipe sizing" of the installation manual.
- Check the set temperature, and change the dipswitch setting. Refer to Section D.
- Refer to "Water circuit" in this section.

### <<The water is too hot>>

- Check the set temperature, lower setting temperature.

### <<The hot water is not available when a fixture is opened>>

- Refer to the "Power supply circuit" and "Water circuit" in this section.

### <<Fluctuation in hot water temperature>>

- Check if the filter on the cold water inlet cleaned. (Part #406)
- Check if the gas line sized properly and the supply gas pressure sufficient.
- Check for cross connection between cold water lines and hot water lines.
- Refer to "Water circuit" in this section.

### <<Unit does not ignite when water goes through the water heater>>

- Refer to the "Power supply circuit" and "Water circuit" in this section.
- If you use the remote controller, turn the power button on and then the set temperature will be displayed on the screen.
- Check if the filter on the cold water inlet cleaned. (Part #406)

### <<The fan motor still spinning after operation has stopped>>

- This is normal. After operation has stopped, the fan motor keeps running from 15 to 70 seconds in order to re-ignite quickly, as well as purge all the exhaust gas out of the flue.

### <<Abnormal sound from water heater>>

- An abnormal sound from the water heaters is caused by not enough air supply or wrong installations. The water heater needs more combustion air. Refer to the "10" error code in the section B.

### <<Power supply circuit>>

- If the remote controller installed, press the "ON/OFF" button of the remote controller, and make sure that the set temperature is displayed on the remote controller. Restart the water heater.
- Check if the Red LED on the PCB (Part #701) of the water heater is lit for a few seconds right after the power is supplied. If so, the power supply circuit of the water heater is under normal condition. Next, refer to the "Water circuit" in this section.
- Check the fuse on the surge box (Part #703), and if it has a brown spot, need to replace it.
- Check the power supply, and make sure that the water heater has 120 VAC.
- If the Red LED on the PCB (Part #701) isn't lit, some electrical parts can be broken. **Consult the manufacturer.**

### <<Water circuit>>

- If you set the remote controller, turn the power button on and then the set temperature will be displayed on the screen.
- Open all hot water faucets, and make sure that there is enough water flow. This water heater needs at least 0.5 GPM water flow (at the default set temperature) to operate.
- Check for reverse connection and cross connection.
- Check if the filter on the cold water inlet cleaned. (Part #406)
- Check if there is no debris or obstruction on the fixtures.
- Check if water ways in the water heater are frozen. If so, unfreeze them. And refer to installation manual to protect your water heater from freeze.
- Check if the inlet water pressure is higher than 40 psi. And if it's lower than 40 psi, need to increase the pressure.
- Check for connections and breakage of wires (Part #402).
- Check if the motor drive of the flow adjustment valve (Part #402) is locked due to scale buildup, and/or water leakage. **Consult the manufacturer.**

## C. Wiring Diagram and check point of the Water heater

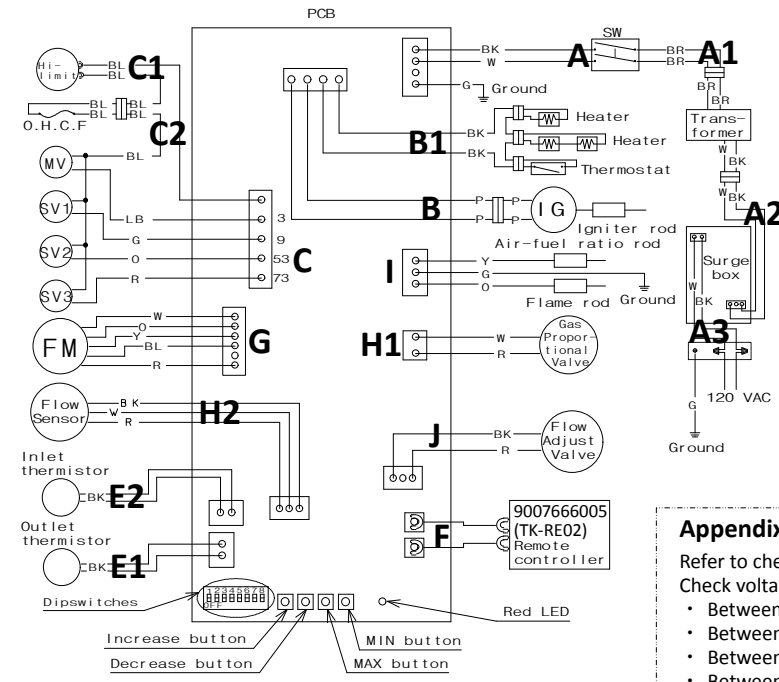

BK: BLACK R: RED BL: BLUE Y: YELLOW LB: LIGHT BLUE  
W: WHITE G: GREEN O: ORANGE BR: BROWN P: PURPLE

### Appendix A (For error code 11)

#### Check these points during ignition stage.

- Refer to check point "B" on the wiring diagram above. Check voltage between purple wires. (Normal: 90 to 110 VAC)  
**This Check point is normal?**  
**Yes >> Replace the igniter (Part #711)**  
**No >> Go to Next**
- Refer to check point "C" and "H1" on the wiring diagram above. Check the voltage bellows.  
C: Between blue wire and light blue wire (#3). (Normal: 78 to 100 VDC)  
C: Between blue wire and orange wire (#53). (Normal: 78 to 100 VDC)  
H1: Check the voltage between white wire and red wire. (Normal: 1 to 15 VDC)  
**These check points are normal?**  
**Yes >> Replace the gas valves assembly. (Part #102)**  
**No >> Replace the PCB. (Part #701)**
- Check current thought the orange flame rod wire (Part #709). (Normal: more than 1μA)  
**This check point is normal during operation?**  
**Yes >> Replace the PCB. (Part #701)**  
**No >> Replace the flame rod. (Part #108)**

### Appendix B (For error code 61)

Refer to check point "G" in the diagram to the left and followings.

- Check voltage between red wire and blue wire. (Normal: 110 to 160 VDC)
- Check voltage between yellow wire and blue wire. (Normal: 13 to 17 VDC)
- Check voltage between orange wire and blue wire (Normal: 2.0 to 6.5 VDC)  
**All check points are normal?**  
**Yes >> Replace the fan motor. (Part #103)**  
**No >> Replace the PCB. (Part #701)**

### Appendix C (For error code 51 and 55)

Refer to check point "C" in the diagram to the left and followings.

- Check voltage on the each valve on the gas valves assembly.
  - Between blue wire and light blue wire (#3). (Normal: 78 to 100 VDC)
  - Between blue wire and green wire (#9). (Normal: 78 to 100 VDC)
  - Between blue wire and orange wire (#53). (Normal: 78 to 100 VDC)
  - Between blue wire and red wire (#73). (Normal: 78 to 100 VDC)
- All check points are normal?**  
**Yes >> Replace the gas valves assembly. (Part #102)**  
**No >> Replace the PCB. (Part #701)**

### Appendix D (For error code 31 and 32)

- Outlet thermistor (Find the marking of No.113 on the connector) Check point "E1"
  - Inlet thermistor (Find the marking of No.42 on the connector) Check point "E2"
- Check resistance between black wire and black wire.

Temperature	°F	50	59	68	77	86	95
	°C	10	15	20	25	30	35
Resistance	kΩ	15.4	12.6	10.3	8.5	7.0	5.9

- All check points are normal?**  
**Yes >> Replace the PCB. (Part #701)**  
**No >> Replace the wrong thermistor. (Part #407, 408)**

### Appendix E (For error code 74)

- Refer to check point "F" on the wiring diagram above. Check voltage on the remote controller terminal on the PCB. (Normal: 11 to 25 VDC)  
**This check point is normal?**  
**Yes >> Replace the remote controller.**  
**No >> Replace the PCB. (Part #701)**

## B. Error codes

The numbers in parentheses below are the numbers of blinking of the Red LED on the PCB to indicate the error codes.

### 03 (One Time): Incorrect dipswitch setting

- Check the dipswitch settings on the PCB. Refer to Section D.

### 10 (Five Times): Warning for the "99" error code

- Check the gas type of the water heater. If it's wrong gas type model, replace the water heater to correct one.
- Check if there is any blockage (For example, Damper sticking, Vent Flaps installed on the terminator, Snow build up around terminator, Installed in a closet (No ventilation or lack of combustion air) in the intake air and/or exhaust. Refer to the "Vent termination clearances" of the installation manual.
- If the water heater is installed as a direct-vent system, check whether there is enough distance between the intake air terminal and the exhaust terminal. Refer to the "Vent termination clearances" of the installation manual.
- Check if the total vent length doesn't exceed 50 ft and the # of elbows is less than 5Ea.
- Check the altitude/elevation of area of where the water heater installed. Refer to the "High-altitude function" of the Section D. And change the dipswitch settings.
- Check if there is grease and/or dirt in the burner (Part #101) and the fan motor (Part #103), especially if the water heater has been installed in a contaminated area.
- Check if there is dust and lint in heat exchanger.
- Check the manifold pressure of the water heater. Refer to installation manual.

### 11 (Three Times): Ignition failure

- Check gas supply and inlet gas pressure.
- Check if the Hi-limit switch (Part #412) is properly functioning.
- Check for connection/breakage of wires (Part #413, 708, 709, 712), burn marks on the computer board (Part #701), and/or soot on the flame rod (Part #108). And then if O.H.C.F (Part #413) is breakage, **Consult the manufacturer.**
- Check if there is a buzzing spark ignition sound coming from the burner (Part #101) when water heater prepares for combustion.
- Listen for the double "clunk" sound coming from the gas valves assembly (Part #102) when water heater goes into combustion.
- (Only no sparking and/or kick sound) Check voltage on each wire to gas valves assembly (Part #102) and/or the igniter (Part #711). Refer to the "Appendix A" in Section C.  
\*No sparking sound >>>> Refer to the #1 at "Appendix A" in Section C.  
\*No kick sound >>>> Refer to the #2 at "Appendix A" in Section C.
- Check if there is leaking from heat exchanger (Part #401)
- Check if there is dust and lint in nozzles of the manifold (Part #102).
- Check current on the flame rod (Part #108). Refer to the #3 at "Appendix A" in Section C.

### 12 (Three Times): Loss of flame

- Check gas supply and inlet gas pressure.
- Check if the Hi-limit switch (Part #412) is properly functioning.
- Check for connection/breakage of wires (Part #413, 708, 709, 712), burn marks on the computer board (Part #701), soot on the flame rod (Part #108). And then if O.H.C.F (Part #413) is breakage, **Consult the manufacturer.**
- Check if there is leakage from heat exchanger (Part #401).
- Check if there is dust and lint in nozzles of the manifold (Part #102).
- Check current on the flame rod (Part #108). Refer to the #3 at "Appendix A" in Section C.

### 31, 32 (Two Times): Disconnected/short-circuited thermistor

- Check for connection/breakage of wires and/or debris on thermistor (Part #407, 408).
- Check thermistor resistance. Refer to the "Appendix D" in Section C.

### 39 (Two Times): Air-fuel Ratio Rod failure

- Check for connection/breakage of wires (Part #709) and/or soot on the AFR rod. (Part #108).

### 51, 55 (Six Times): Abnormal Gas Solenoid Valve and Main Gas Valve

- Check for connection/breakage of wires (Part #708) and/or burn marks on the computer board (Part #701).
- Reset power supply of the water heater.
- Check voltage on the each valve on the gas valves assembly (Part #102). Refer to the "Appendix C" in Section C.

### 61 (Four Times): Fan motor fault

- Check for connection/breakage of wires, dust buildup in the fan motor (Part #103) and/or burn marks on the computer board (Part #701).
- Check for frozen/corrosion of connectors of the fan motor (Part #103).
- Check voltage between blue wire and each wire of the fan motor (Part #103), and check resistance between white wire and red wire. Refer to the "Appendix B" in Section C.

### 70 (One Time): Computer board fault

- Check for connection/breakage of wires (Part #714) and/or burn marks on the computer board (Part #701).

### 72 (Six Times): False flame detection

- Clean the flame rod (Part #108).
- For indoor models, check if condensate drain is installed on the vent collar of the water heater.
- Check if there is leaking from heat exchanger (Part #401).

### 74: Miscommunication between water heater and remote controller

- Check the model type of the remote controller. Model No. 9007666005 (TK-RE02) is the correct one.
- Inspect the connections between the water heater and remote controller. Refer to "Remote controller connections" of the Installation manual.
- Check the power supply of the water heater.
- If this error code appears only the Red LED on the PCB (Part #701), check the voltage on the remote controller terminal on the PCB. Refer to the "Appendix E" in Section C.
- If this error code appears only remote controller, replace the PCB (Part #701).
- If this error code appears both the PCB (Part #701) and the remote controller, replace the remote controller.

### 99 (Five Times): Imperfect combustion

- Refer to the "10" error code in this section.

## D. Dipswitch Settings on the computer board of the water heater

Change the dipswitch settings when the power supply is turning off. The dark square is the direction the dipswitch should be set to. DEFAULT is the factory setting.

The dipswitches have certain special functions and generally should not need adjustment. They have settings for four functions, shown below.

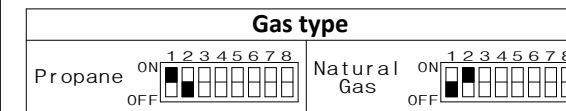

The Gas Type dipswitch should already be properly preset from the factory.

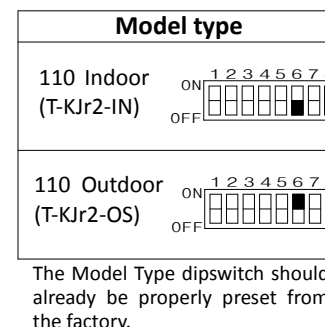
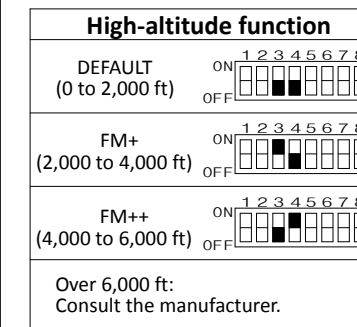

The Model Type dipswitch should already be properly preset from the factory.

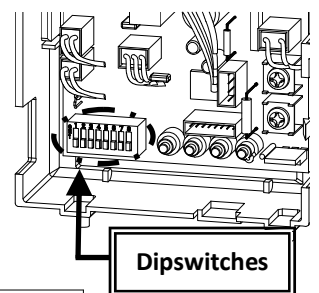
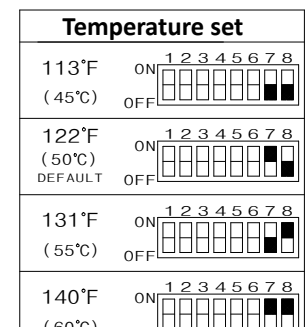

# E. Components Diagram / Parts List

## Case assembly

### 110 Indoor (T-KJr2-IN)

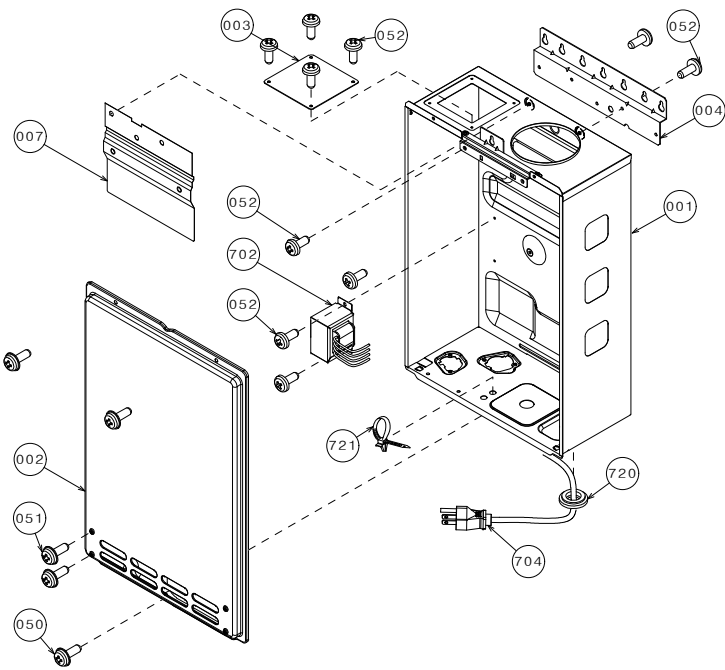

### 110 Outdoor (T-KJr2-OS)

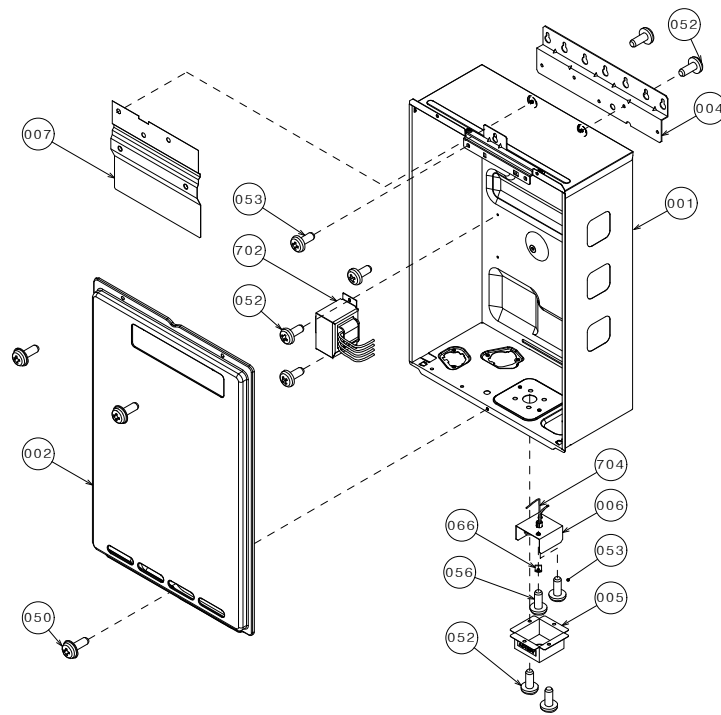

Item#	Part#		Description
	110 models	T-KJr2 models	
001	319143-159	EK415	Case assembly for 110 Indoor (T-KJr2-IN)
	319143-172	EK432	Case assembly for 110 Outdoor (T-KJr2-OS)
002	319143-163	EK419	Front cover for 110 Indoor (T-KJr2-IN)
	319143-173	EK433	Front cover for 110 Outdoor (T-KJr2-OS)
003	319143-150	EK401	Air blockage plate (Only 110 Indoor and T-KJr2-IN)
004	319143-184	EKJ09	Bracket
005	319143-014	EKJ64	Junction box
006	319143-128	EKJ66	Junction box inner plate
007	319143-338	EX00M	Back guard panel
050	319143-025	EW000	Screw M4x12 (W/Washer)
051	319143-325	EW001	Screw M4x10 (W/Washer)
052	319143-026	EW002	Screw M4x10 (Coated)
053	319143-060	EW003	Screw M4x10
055	319143-063	EW005	Hex head screw M4x8
056	319143-372	EX014	Screw M4x10
058	319143-327	EW008	Screw M3x10
059	319143-061	EW00H	Pan screw M4x12 (W/Washer)
061	319143-201	EKK31	Tap tight screw M4x12 FEZN
062	319143-062	EW006	Pan screw M4x10
063	319143-087	EW00A	Screw M3x6
064	319143-328	EW009	Screw M4x6
065	319143-059	EW00D	Pan screw M4x8
066	319143-143	EC00X	Nylon clamp
067	319143-048	EM167	Wire clamp 60

## Computer board assembly

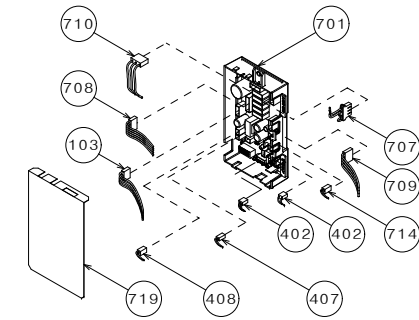

## Temperature remote controller

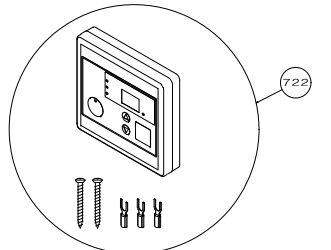

Item#	Part#		Description
	110 models	T-KJr2 models	
701	319143-164	EK420	Computer board
702	319143-182	EKH09	Transformer
703	319143-168	EK428	Surge box
704	319143-427	EK146	AC120V wire for Indoor models
	319143-222	EKK5M	AC120V wire for Outdoor models
705	319143-155	EK408	Transformer wire
706	319143-141	EKK4V	AC120V Power ON-OFF switch
707	319143-154	EK407	Switch wire
708	319143-207	EKK3K	Gas valve wire
709	319143-171	EK431	Flame rod wire
710	319143-209	EKK3R	EH-IG Wire for 110 Indoor (T-KJr2-IN)
	319143-210	EKK40	EH-IG Wire with freeze protection thermostat for 110 Outdoor (T-KJr2-OS)
711	319143-052	EKN74	Igniter
712	319143-039	EKK2M	High voltage igniter wire
713	319143-185	EKJ59	Freeze protection thermostat (Only 110 Indoor and T-KJr2-IN)
714	319143-220	EKK58	Proportional gas valve wire
719	319143-212	EKK49	Computer board cover
720	319143-426	EK148	Rubber grommet for Indoor models
721	319143-425	EW022	Cable strap for Indoor models
722	319143-352	ER016	Temperature remote controller

## Burner assembly

### Burner assembly

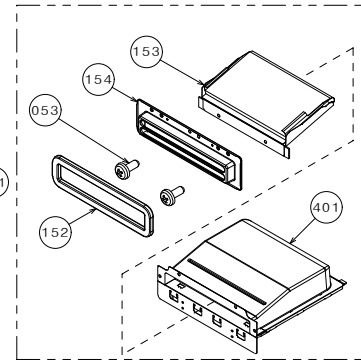
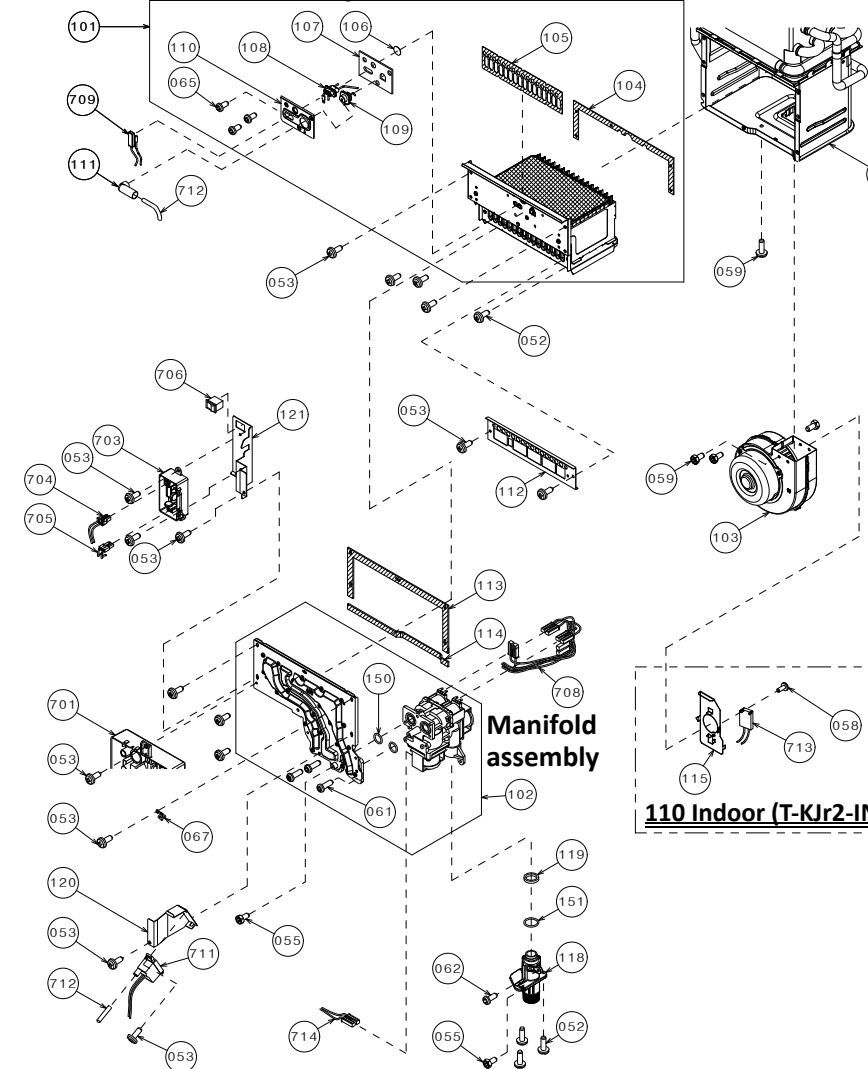

### Exhaust section for 110 Outdoor (T-KJr2-IN)

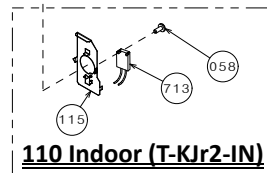

### 110 Indoor (T-KJr2-IN)

Item#	Part#		Description
	110 models	T-KJr2 models	
101	319143-161	EK417	Burner assembly
102	319143-169	EK429	Manifold assembly with gas valve assembly LP
	319143-165	EK421	Manifold assembly with gas valve assembly NA
103	319143-347	EX02E	Fan motor
104	319143-341	EX00V	Burner holder gasket
105	319143-031	EKK2X	Burner gasket
106	319143-033	EKK2V	Burner window
107	319143-034	EKK2W	Rod holder gasket
108	319143-339	EX00R	Flame rod
109	319143-373	EX00S	Igniter rod
110	319143-340	EX00U	Rod holder
111	319143-038	EKN61	Rod cap
112	319143-170	EK430	Burner damper
113	319143-044	EKK2Y	Manifold gasket A
114	319143-045	EKK2K	Manifold gasket B
115	319143-160	EK416	Fan damper (Only 110 Indoor and T-KJr2-IN)
118	319143-050	EKK1E	Gas inlet
119	319143-049	EKK2Z	Gas inlet ring
120	319143-051	EKK1B	Igniter plate
121	319143-213	EKK4H	Surge box plate
150	319143-350	EZP18	O-ring P18 NBR (Black)
151	319143-057	EK042	O-ring P20 NBR (Black)
152	319143-370	EK442	Silicon ring (Only 110 Outdoor and T-KJr2-OS)
153	319143-216	EKK53	Rain protection plate in Exhaust chamber (Only 110 Outdoor and T-KJr2-OS)
154	319143-219	EKK56	Exhaust port (Only 110 Outdoor and T-KJr2-OS)

## Water way assembly

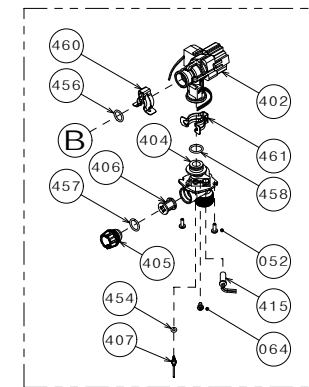

### Water inlet section

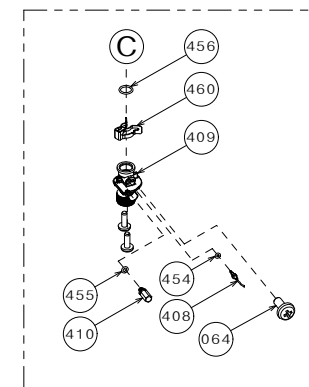

### Water outlet section

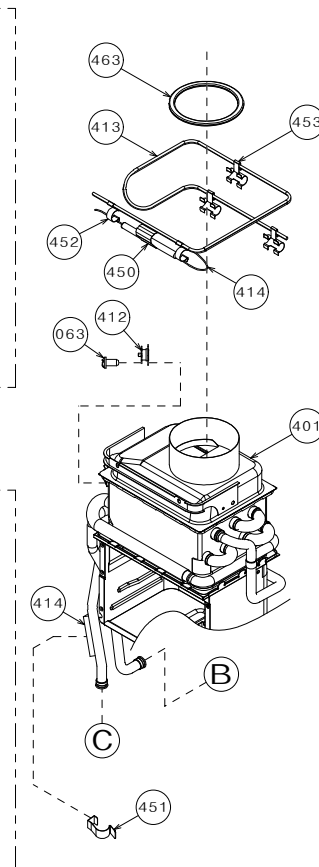

Item#	Part#		Description
	110 models	T-KJr2 models	
401	319143-162	EK418	Heat exchanger assembly for 110 Indoor (T-KJr2-IN)
	319143-166	EK426	Heat exchanger assembly for 110 Outdoor (T-KJr2-OS)
402	319143-167	EK427	Flow adjustment valve/ Flow sensor
404	319143-193	EKK1U	Water inlet
405	319143-197	EKK2B	Inlet drain plug
406	319143-198	EKK2C	Inlet water filter
407	319143-214	EKK4J	Inlet thermistor
408	319143-218	EKK55	Outlet thermistor
409	319143-194	EKK1V	Water outlet
410	319143-199	EKK2E	Outlet drain plug
412	319143-228	EM212	Hi-Limit switch
413	319143-149	EK333	Overheat cut-off-fuse
414	319143-200	EKK2R	Heater
415	319143-078	EKK2P	Inlet heater
450	319143-088	EKK27	Pipe heater fixing plate
451	319143-125	EK031	Heater fixing plate 16
452	319143-066	EKK26	Fuse fixing plate 18
453	319143-146	EK029	Fuse fixing plate 14
454	319143-082	EZM04	O-ring P4 FKM
455	319143-080	EZM06	O-ring P6 FKM
456	319143-100	EZM14	O-ring P14 FKM
457	319143-091	EZM15	O-ring P15 FKM
458	319143-083	EZM16	O-ring P16 FKM
460	319143-105	EKK24	Fastener "14-22"
461	319143-226	EM192	Fastener "16A"
463	319143-065	EKN50	Silicon ring (Only 110 Indoor and T-KJr2-IN)