



SKYHAWK

SURVEILLANCE

SATA Product Manual

Standard model

ST8000VX0022

ST6000VX0023

ST4000VX007

ST3000VX010

ST2000VX008

ST1000VX005

100804836, Rev. E
September 2017

Document Revision History

Revision	Date	Pages affected and Description of Change
Rev. A	10/12/2016	Initial release.
Rev. B	10/17/2016	9: Table 1 Op Shock value 23: Changed Figure 3 to 8TB only 24-26: New mechanical drawings for 6TB, 4TB & 3-2TB 32: Word 98-99 Streaming Performance Granularity = 2710 _H / 0000 _H
Rev. C	06/21/2017	27: Revised Mechanical Drawing (Fig 7) Z-heights to 20.20 mm
Rev. D	08/28/2017	10 & 16: Updated 1-4TB Operating ambient temperature (min °C) to 0
Rev. E	09/08/2017	23, 25-27: Updated fastener penetration depth to 0.120" in Section 3.4 & Figures 3 & 5-7

© 2017, Seagate Technology LLC All rights reserved.

Publication number: 100804836, Rev. E September 2017

Seagate, Seagate Technology and the Spiral logo are registered trademarks of Seagate Technology LLC in the United States and/or other countries. SeaTools is either trademarks or registered trademarks of Seagate Technology LLC or one of its affiliated companies in the United States and/or other countries. All other trademarks or registered trademarks are the property of their respective owners.

No part of this publication may be reproduced in any form without written permission of Seagate Technology LLC.

Call 877-PUB-TEK1 (877-782-8351) to request permission.

When referring to drive capacity, one gigabyte, or GB, equals one billion bytes and one terabyte, or TB, equals one trillion bytes. Your computer's operating system may use a different standard of measurement and report a lower capacity. In addition, some of the listed capacity is used for formatting and other functions, and thus will not be available for data storage. Actual quantities will vary based on various factors, including file size, file format, features and application software. Actual data rates may vary depending on operating environment and other factors. The export or re-export of hardware or software containing encryption may be regulated by the U.S. Department of Commerce, Bureau of Industry and Security (for more information, visit www.bis.doc.gov), and controlled for import and use outside of the U.S. Seagate reserves the right to change, without notice, product offerings or specifications.

Seagate® Technology Support Services	5
---	----------

1.0 Introduction	6
1.1 About the SATA interface	7

2.0 Drive Specifications	8
2.1 Specification summary tables	8
2.2 Formatted capacity	11
2.2.1 LBA mode	11
2.3 Default logical geometry	12
2.4 Seek time	12
2.5 Start/stop times	12
2.6 Power specifications	13
2.6.1 Power consumption	13
2.6.2 Typical current profile	14
2.6.3 Conducted noise	15
2.6.4 Voltage tolerance	15
2.6.5 Power-management modes	15
2.7 Environmental specifications	16
2.7.1 Drive case temperature	16
2.7.2 Temperature	16
2.7.3 Temperature gradient	16
2.7.4 Humidity	16
2.7.5 Altitude	16
2.7.6 Shock	17
2.7.7 Vibration	17
2.8 Acoustics	18
2.8.1 Test for Prominent Discrete Tones (PDTs)	18
2.9 Electromagnetic immunity	18
2.10 Reliability - Mean Time Between Failure	19
2.10.1 Storage	19
2.11 Warranty	19
2.12 Agency certification	19
2.12.1 Safety certification	19
2.12.2 Electromagnetic compatibility	19
2.12.3 FCC verification	20
2.13 Environmental protection	20
2.13.1 European Union Restriction of Hazardous Substances (RoHS) Directive	20
2.13.2 China Requirements — China RoHS 2	21
2.14 Corrosive environment	21

3.0	Configuring and Mounting the Drive	22
3.1	Handling and static-discharge precautions	22
3.2	Configuring the drive	22
3.3	SATA cables and connectors	22
3.4	Drive mounting	23

4.0	SATA Interface	28
4.1	Hot-Plug compatibility	28
4.2	SATA device plug connector pin definitions	28
4.3	Supported ATA commands	29
4.3.1	Identify Device command	31
4.3.2	Set Features command	35
4.3.3	S.M.A.R.T. commands	36

Figures

Figure 1	Typical Current Profile for 2TB to 8TB models (5V & 12V)	14
Figure 2	Attaching SATA cabling.....	22
Figure 3	Mounting dimensions (8TB).....	23
Figure 4	Mounting dimensions (6TB).....	24
Figure 5	Mounting dimensions (4TB).....	25
Figure 6	Mounting dimensions (3TB - 2TB)	26
Figure 7	Mounting dimensions (1TB).....	27

Seagate® Technology Support Services

For information regarding online support and services, visit: <http://www.seagate.com/contacts/>

For information regarding Warranty Support, visit: <http://www.seagate.com/support/warranty-and-replacements/>

For information regarding data recovery services, visit: <http://www.seagate.com/services-software/recover/>

For Seagate OEM, Distribution partner and reseller portals, visit: <http://www.seagate.com/partners/>

1.0 Introduction

This manual describes the functional, mechanical and interface specifications for the following: Seagate® SkyHawk™ model drives:

ST8000VX0022 ST6000VX0023 ST4000VX007 ST3000VX010 ST2000VX008 ST1000VX005

These drives provide the following key features:

- 24x7 capability
- Balance technology to support multiple drives in a system
- Compliant with RoHS requirements in China and Europe
- Full-track multiple-sector transfer capability without local processor intervention
- Low activity and idle power
- Low-RPM spindle speed
- Native Command Queuing with command ordering to increase performance in demanding applications
- Off-the-shelf compatibility
- Performance-tuned for RAID applications
- Rated for 1M hours MTBF
- SeaTools diagnostic software performs a drive self-test that eliminates unnecessary drive returns.
- State-of-the-art cache and on-the-fly error-correction algorithms
- Streaming video optimization - consistent command completion times & ERC support
- Support for S.M.A.R.T. drive monitoring and reporting
- Supports ATA8 streaming commands
- Supports latching SATA cables and connectors
- TGMR recording technology provides the drives with increased areal density.
- Worldwide Name (WWN) capability uniquely identifies the drive

1.1 About the SATA interface

The Serial ATA (SATA) interface provides several advantages over the traditional (parallel) ATA interface. The primary advantages include:

- Easy installation and configuration with true plug-and-play connectivity. It is not necessary to set any jumpers or other configuration options.
- Thinner and more flexible cabling for improved enclosure airflow and ease of installation.
- Scalability to higher performance levels.

In addition, SATA makes the transition from parallel ATA easy by providing legacy software support. SATA was designed to allow users to install a SATA host adapter and SATA disk drive in the current system and expect all of the existing applications to work as normal.

The SATA interface connects each disk drive in a point-to-point configuration with the SATA host adapter. There is no master/slave relationship with SATA devices like there is with parallel ATA. If two drives are attached on one SATA host adapter, the host operating system views the two devices as if they were both “masters” on two separate ports. This essentially means both drives behave as if they are Device 0 (master) devices.

The SATA host adapter and drive share the function of emulating parallel ATA device behavior to provide backward compatibility with existing host systems and software. The Command and Control Block registers, PIO and DMA data transfers, resets, and interrupts are all emulated.

The SATA host adapter contains a set of registers that shadow the contents of the traditional device registers, referred to as the Shadow Register Block. All SATA devices behave like Device 0 devices. For additional information about how SATA emulates parallel ATA, refer to the “Serial ATA International Organization: Serial ATA Revision 3.2”. The specification can be downloaded from www.sata-io.org.

Note

The host adapter may, optionally, emulate a master/slave environment to host software where two devices on separate SATA ports are represented to host software as a Device 0 (master) and Device 1 (slave) accessed at the same set of host bus addresses. A host adapter that emulates a master/slave environment manages two sets of shadow registers. This is not a typical SATA environment.

2.0 Drive Specifications

Unless otherwise noted, all specifications are measured under ambient conditions, at 25°C, and nominal power. For convenience, the phrases *the drive* and *this drive* are used throughout this manual to indicate the following drive models:

ST8000VX0022 ST6000VX0023 ST4000VX007 ST3000VX010 ST2000VX008 ST1000VX005

2.1 Specification summary tables

The specifications listed in [Table 1](#) are for quick reference. For details on specification measurement or definition, refer to the appropriate section of this manual.

Table 1 Drive specifications summary for 8TB and 6TB models

Drive Specification*	ST8000VX0022	ST6000VX0023
Formatted capacity (512 bytes/sector)**	8000GB (8TB)	6000GB (6TB)
Guaranteed sectors	15,628,053,168	11,721,045,168
Heads	12	10
Disks	6	5
Bytes per sector (4K physical emulated at 512-byte sectors)	4096	
Default sectors per track	63	
Default read/write heads	16	
Default cylinders	16,383	
Recording density (max)	2177KBPI	1984KBPI
Track density (avg)	370KTPI	
Areal density (avg)	802Gb/in ²	732Gb/in ²
Internal data transfer rate (max)	1981Mb/s	
Maximum sustained data rate, OD read (MB/s)	210MB/s	
ATA data-transfer modes supported	PIO modes: 0 to 4 Multiword DMA modes: 0 to 2 Ultra DMA modes 0 to 6	
I/O data-transfer rate (max)	600MB/s	
Cache buffer	256MB	
Height (max)	26.1mm / 1.028 in	
Width (max)	101.6mm / 4.010 in	
Length (max)	146.99mm / 5.787 in	
Weight (max)	780g / 1.72 lb	705g / 1.55 lb
Average latency	4.0ms	
Average seek, read (typical)	<8.5ms	
Average seek, write (typical)	<9.5ms	
Startup current (typical) 12V	1.8A	
Voltage tolerance (including noise)	5V: ±5% 12V: ±10%	
Non-Operating (Ambient °C)	-40 to 70	
Operating ambient temperature (min °C)	5	
Operating temperature (drive case max °C)	70 [†]	
Temperature gradient	20°C per hour max (operating) 30°C per hour max (nonoperating)	
Relative humidity	5% to 90% (operating) 5% to 95% (nonoperating)	
Relative humidity gradient (max)	30% per hour	

Table 1 Drive specifications summary for 8TB and 6TB models (continued)

Drive Specification*	ST8000VX0022	ST6000VX0023
Wet bulb temperature (max)	26°C max (operating) 29°C max (nonoperating)	
Altitude, operating	-304m to 3048m (-1000 ft to 10,000 ft)	
Altitude, non-operating (below mean sea level, max)	-304m to 12,192m (-1000ft to 40,000+ ft)	
Operational Shock (max)	70 Gs at 2ms	
Non-Operational Shock (max)	250 Gs at 2ms	
Vibration, operating	2Hz to 22Hz: 0.25 Gs, Limited displacement 22Hz to 350Hz: 0.50 Gs 350Hz to 500Hz: 0.25 Gs	
Vibration, non-operating	5Hz to 22Hz: 3.0 Gs 22Hz to 350Hz: 3.0 Gs 350Hz to 500Hz: 3.0 Gs	
Drive acoustics, sound power		
Idle***	2.7 bels (typical) 2.8 bels (max)	
Seek	2.8 bels (typical) 2.9 bels (max)	
Non-recoverable read errors	1 per 10 ¹⁵ bits read	
Mean time between failures (MTBF), hours	1M	
Rated Workload	Average annualized workload rating: <180 TB/year. The AFR specification for the product assumes the I/O workload does not exceed the average annualized workload rate limit of 180 TB/year. Workloads exceeding the annualized rate may degrade the product AFR and impact reliability as experienced by the particular application. The average annualized workload rate limit is in units of TB per calendar year.	
Warranty	To determine the warranty for a specific drive, use a web browser to access the following web page: http://www.seagate.com/support/warranty-and-replacements/ From this page, click on "Is my Drive under Warranty". Users will be asked to provide the drive serial number, model number (or part number) and country of purchase. The system will display the warranty information for the drive.	
Load/Unload cycles (25°C, 50% rel. humidity)	300,000	
Supports Hotplug operation per the Serial ATA Revision 3.2 specification	Yes	

The following table footnotes apply to **Table 1** and **Table 2**:

* All specifications above are based on native configurations.

** One GB equals one billion bytes and 1TB equals one trillion bytes when referring to hard drive capacity. Accessible capacity may vary depending on operating environment and formatting.

*** During periods of drive idle, some offline activity may occur according to the S.M.A.R.T. specification, which may increase acoustic and power to operational levels.

† Seagate does not recommend operating at sustained case temperatures above 60°C. Operating at higher temperatures will reduce useful life of the product.

Table 2 Drive specifications summary for 4TB - 1TB models

Drive Specification*	ST4000VX007	ST3000VX010	ST2000VX008	ST1000VX005
Formatted capacity (512 bytes/sector)**	4000GB (4TB)	3000GB (3TB)	2000GB (2TB)	1000GB (1TB)
Guaranteed sectors	7,814,037,168	5,860,533,168	3,907,029,168	1,953,525,168
Heads	6	6/5	4	2
Disks	3	3	2	1
Bytes per sector (4K physical emulated at 512-byte sectors)	4096			
Default sectors per track	63			
Default read/write heads	16			
Default cylinders	16,383			
Recording density (max)	2089kBPI	1740kBPI	1807kFCI	
Track density (avg)	388ktracks/in	346ktracks/in	352ktracks/in	
Areal density (avg)	810Gb/in ²	613Gb/in ²	625Gfc/in ²	
Internal data transfer rate (max)	2107Mb/s	1813Mb/s	2147Mb/s	
Maximum sustained data rate, OD read (MB/s)	190MB/s	180MB/s		
ATA data-transfer modes supported	PIO modes: 0 to 4 Multiword DMA modes: 0 to 2 Ultra DMA modes 0 to 6			
I/O data-transfer rate (max)	600MB/s			
Cache buffer	64MB			
Height (max)	26.1mm / 1.028 in			20.20mm / 0.795 in
Width (max)	101.6mm / 4.010 in			
Length (max)	146.99mm / 5.787 in			
Weight (max)	635g / 1.345 lb	610g / 1.40 lb	415g / 0.915 lb	
Average latency	5.1ms			
Power-on to ready (max)	<17.0s			<6.0s
Standby to ready (max)	<17.0s			<6.0s
Average seek, read (typical)	<12.0ms			<8.5ms
Average seek, write (typical)	<12.0ms			<19.5ms
Startup current (typical) 12V	1.8A			1.2A
Voltage tolerance (including noise)	5V: ±5% 12V: ±10%			
Non-Operating (Ambient °C)	-40 to 70			
Operating ambient temperature (min °C)	0			
Operating temperature (drive case max °C)	70 †			
Temperature gradient	20°C per hour max (operating) 30°C per hour max (nonoperating)			
Relative humidity	5% to 90% (operating) 5% to 95% (nonoperating)			
Relative humidity gradient (max)	30% per hour			
Wet bulb temperature (max)	26°C max (operating) 29°C max (nonoperating)			
Altitude, operating	-304m to 3048m (-1000 ft to 10,000 ft)			
Altitude, non-operating (below mean sea level, max)	-304m to 12,192m (-1000ft to 40,000+ ft)			
Operational Shock (max)	80 Gs at 2ms			

Table 2 Drive specifications summary for 4TB - 1TB models (continued)

Drive Specification*	ST4000VX007	ST3000VX010	ST2000VX008	ST1000VX005
Non-Operational Shock (max)	300 Gs at 2ms			
Vibration, operating	2Hz to 22Hz: 0.25 Gs, Limited displacement 22Hz to 350Hz: 0.50 Gs 350Hz to 500Hz: 0.25 Gs			
Vibration, non-operating	5Hz to 22Hz: 3.0 Gs 22Hz to 350Hz: 3.0 Gs 350Hz to 500Hz: 3.0 Gs			
Drive acoustics, sound power				
Idle***	2.3 bels (typical) 2.4 bels (max)		1.9 bels (typical) 2.0 bels (max)	
Seek	2.5 bels (typical) 2.6 bels (max)		2.1 bels (typical) 2.2 bels (max)	
Non-recoverable read errors	1 per 10 ¹⁴ bits read			
Mean time between failures (MTBF), hours	1M			
Rated Workload	Average annualized workload rating: <180 TB/year. The AFR specification for the product assumes the I/O workload does not exceed the average annualized workload rate limit of 180 TB/year. Workloads exceeding the annualized rate may degrade the product AFR and impact reliability as experienced by the particular application. The average annualized workload rate limit is in units of TB per calendar year.			
Warranty	To determine the warranty for a specific drive, use a web browser to access the following web page: http://www.seagate.com/support/warranty-and-replacements/ From this page, click on "Is my Drive under Warranty". Users will be asked to provide the drive serial number, model number (or part number) and country of purchase. The system will display the warranty information for the drive.			
Load/Unload cycles (25°C, 50% rel. humidity)	300,000		—	
Contact start-stop cycles (25°C, 50% rel. humidity)	—		50,000	
Supports Hotplug operation per the Serial ATA Revision 3.2 specification	Yes			

2.2 Formatted capacity

Model	Formatted capacity*	Guaranteed sectors	Bytes per sector
ST8000VX0022	8000GB	15,628,053,168	4096
ST6000VX0023	6000GB	11,721,045,168	
ST4000VX007	4000GB	7,814,037,168	
ST3000VX010	3000GB	5,860,533,168	
ST2000VX008	2000GB	3,907,029,168	
ST1000VX005	1000GB	1,953,525,168	

*One GB equals one billion bytes and 1TB equals one trillion bytes when referring to hard drive capacity. Accessible capacity may vary depending on operating environment and formatting.

2.2.1 LBA mode

When addressing these drives in LBA mode, all blocks (sectors) are consecutively numbered from 0 to $n-1$, where n is the number of guaranteed sectors as defined above.

See Section 4.3.1, "Identify Device command" (words 60-61 and 100-103) for additional information about 48-bit addressing support of drives with capacities over 137GB.

2.3 Default logical geometry

- **Cylinders:** 16,383
- **Read/write heads:** 16
- **Sectors per track:** 63

LBA mode

When addressing these drives in LBA mode, all blocks (sectors) are consecutively numbered from 0 to $n-1$, where n is the number of guaranteed sectors as defined above.

2.4 Seek time

Seek measurements are taken with nominal power at 25°C ambient temperature. All times are measured using drive diagnostics. The specifications in the table below are defined as follows:

- Track-to-track seek time is an average of all possible single-track seeks in both directions.
- Average seek time is a true statistical random average of at least 5000 measurements of seeks between random tracks, less overhead.

Typical seek times (ms)	Read	Write
Track-to-track	1.0	1.2
Average (1TB - 4TB models)	<12.0	<12.0
Average (6TB and 8TB models)	8.5	9.5
Average latency (1TB - 4TB models)	5.1	
Average latency (6TB and 8TB models)	4.0	

Note

These drives are designed to consistently meet the seek times represented in this manual. Physical seeks, regardless of mode (such as track-to-track and average), are expected to meet the noted values. However, due to the manner in which these drives are formatted, benchmark tests that include command overhead or measure logical seeks may produce results that vary from these specifications.

2.5 Start/stop times

The start/stop times listed below are for all models.

	8TB models	6TB models	2TB, 3TB and 4TB models	1TB models
Power-on to ready (in seconds)	30 (max)	23 (typical) / 30 (max)	15 (typical) / 17 (max)	<6 (max)
Standby to ready (in seconds)	30 (max)		15 (typical) / 17 (max)	<6 (max)
Ready to spindle stop (in seconds)	12 (max)	23 (max)	10 (typical) / 11 (max)	

Time-to-ready may be longer than normal if the drive power is removed without going through normal OS powerdown procedures.

2.6 Power specifications

The drive receives DC power (+5V or +12V) through a native SATA power connector. Refer to [Figure 2 on page 22](#).

2.6.1 Power consumption

Power requirements for the drives are listed in [Table 6](#). Typical power measurements are based on an average of drives tested, under nominal conditions, using 5.0V and 12.0V input voltage at 25°C ambient temperature.

- Spinup power
Spinup power is measured from the time of power-on to the time that the drive spindle reaches operating speed.
- Read/write power and current
Read/write power is measured with the heads on track, based on a 16-sector write followed by a 32-ms delay, then a 16-sector read followed by a 32-ms delay.
- Operating power and current
Operating power is measured using 40 percent random seeks, 40 percent read/write mode (1 write for each 10 reads) and 20 percent drive idle mode.
- Idle mode power
Idle mode power is measured with the drive up to speed, with servo electronics active and with the heads in a random track location.
- Standby mode
During Standby mode, the drive accepts commands, but the drive is not spinning, and the servo and read/write electronics are in power-down mode.

Table 3 DC power requirements for 1TB models

Power dissipation (1-disk values shown)	Avg (watts 25°C)	Avg 5V typ amps	Avg 12V typ amps
Spinup	—	—	1.2
Idle* †	2.502	0.152	0.145
Operating	3.676	0.385	0.145
Standby	0.58	0.096	0.0084
Sleep	0.58	0.096	0.0084

Table 4 DC power requirements for 2TB models

Power dissipation (2-disk values shown)	Avg (watts 25°C)	Avg 5V typ amps	Avg 12V typ amps
Spinup	—	—	1.8
Idle* †	3.56	0.171	0.225
Operating	4.30	0.308	0.233
Standby	0.50	0.09	0.005
Sleep	0.50	0.09	0.005

Table 5 DC power requirements for 3TB and 4TB models

Power dissipation (4-disk values shown)	Avg (watts 25°C)	Avg 5V typ amps	Avg 12V typ amps
Spinup	—	—	1.8
Idle* †	3.95	0.116	0.28
Operating	4.80	0.288	0.283
Standby	0.50	0.09	0.005
Sleep	0.50	0.09	0.005

Table 6 DC power requirements for 6TB & 8TB models

Power dissipation (6-disk values shown)	Avg (watts 25° C)	Avg 5V typ amps	Avg 12V typ amps
Spinup	—	—	1.8
Idle* †	7.60	0.191	0.553
Operating	8.80	0.23	0.54
Standby	0.60	0.09	0.01
Sleep	0.60	0.09	0.01

* Idle1. During periods of drive idle, some offline activity may occur according to the S.M.A.R.T. specification, which may increase acoustic and power to operational levels.

† 5W IDLE with DIPLM Enabled

2.6.2 Typical current profile

Figure 1 Typical Current Profile for 2TB to 8TB models (5V & 12V)

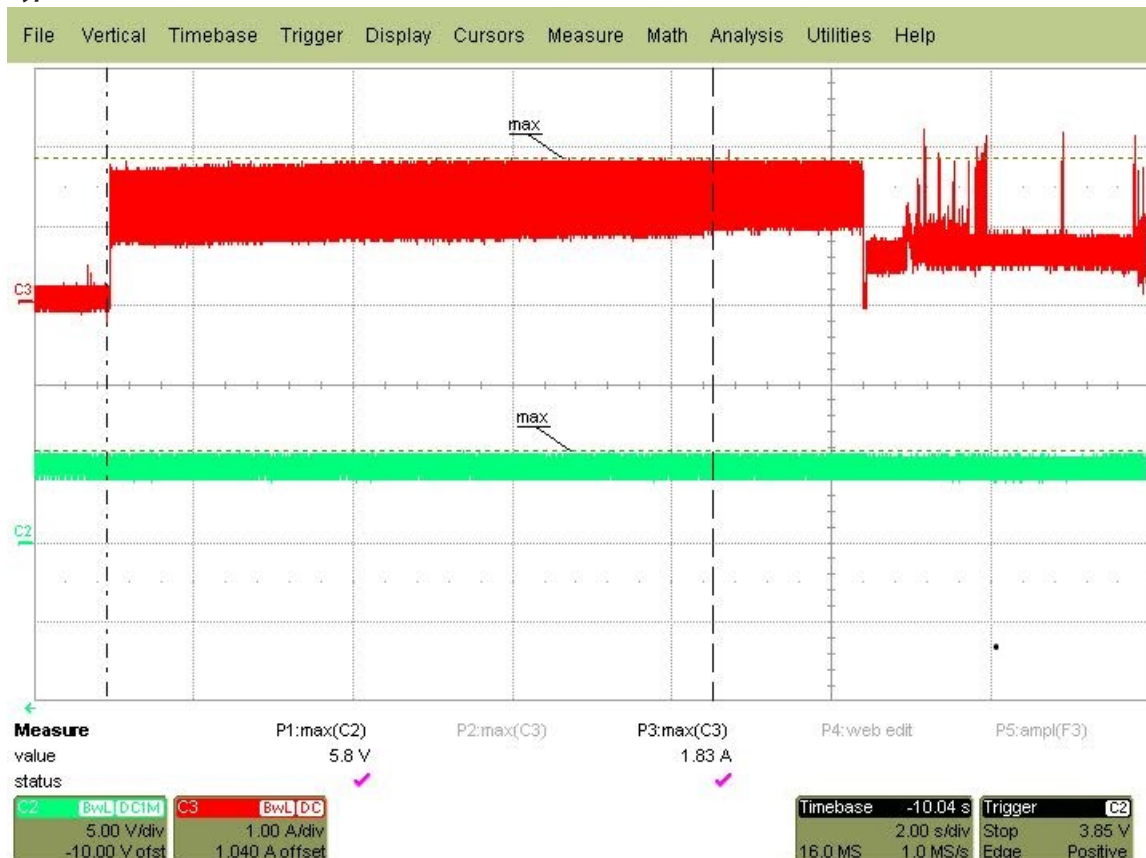

2.6.3 Conducted noise

Input noise ripple is measured at the host system power supply across an equivalent 80-ohm resistive load on the +12 volt line or an equivalent 15-ohm resistive load on the +5 volt line.

- Using 12-volt power, the drive is expected to operate with a maximum of 120 mV peak-to-peak square-wave injected noise at up to 10MHz.
- Using 5-volt power, the drive is expected to operate with a maximum of 100 mV peak-to-peak square-wave injected noise at up to 10MHz.

Note Equivalent resistance is calculated by dividing the nominal voltage by the typical RMS read/write current.

2.6.4 Voltage tolerance

Voltage tolerance (including noise):

- 5V \pm 5%
- 12V \pm 10%

2.6.5 Power-management modes

The drive provides programmable power management to provide greater energy efficiency. In most systems, users can control power management through the system setup program. The drive features the following power-management modes:

Power modes	Heads	Spindle	Buffer
Active	Tracking	Rotating	Enabled
Idle	Tracking	Rotating	Enabled
Standby	Parked	Stopped	Enabled
Sleep	Parked	Stopped	Disabled

- Active mode
 - The drive is in Active mode during the read/write and seek operations.
- Idle mode
 - The buffer remains enabled, and the drive accepts all commands and returns to Active mode any time disk access is necessary.
- Standby mode
 - The drive enters Standby mode when the host sends a Standby Immediate command. If the host has set the standby timer, the drive can also enter Standby mode automatically after the drive has been inactive for a specifiable length of time. The standby timer delay is established using a Standby or Idle command. In Standby mode, the drive buffer is enabled, the heads are parked and the spindle is at rest. The drive accepts all commands and returns to Active mode any time disk access is necessary.
- Sleep mode
 - The drive enters Sleep mode after receiving a Sleep command from the host. In Sleep mode, the drive buffer is disabled, the heads are parked and the spindle is at rest. The drive leaves Sleep mode after it receives a Hard Reset or Soft Reset from the host. After receiving a reset, the drive exits Sleep mode and enters Standby mode with all current translation parameters intact.
- Idle and Standby timers
 - Each time the drive performs an Active function (read, write or seek), the standby timer is reinitialized and begins counting down from its specified delay times to zero. If the standby timer reaches zero before any drive activity is required, the drive makes a transition to Standby mode. In both Idle and Standby mode, the drive accepts all commands and returns to Active mode when disk access is necessary.

2.7 Environmental specifications

This section provides the temperature, humidity, shock, and vibration specifications for NAS HDDs. This section provides the temperature, humidity, shock, and vibration specifications.

2.7.1 Drive case temperature

Ambient temperature is defined as the temperature of the environment immediately surrounding the drive. Above 1000ft. (305 meters), the maximum temperature is derated linearly by 1°C every 1000 ft. Drive case temperature should be measured at the location indicated in [Figure 6](#).

2.7.2 Temperature

Non-operating (Ambient)	-40° to 70°C (-40° to 158°F)
Operating ambient (min °C) (8TB & 6TB models)	5° (41°F)
Operating ambient (min °C) (1-4TB models)	0° (32°F)
Operating (Drive case max °C)	70 † (158°F)

† Seagate does not recommend operating at sustained case temperatures above 60°C. Operating at higher temperatures will reduce useful life of the product.

2.7.3 Temperature gradient

Operating	20°C per hour (36°F per hour max), without condensation
Non-operating	30°C per hour (54°F per hour max)

2.7.4 Humidity

2.7.4.1 Relative humidity

Operating	5% to 90% non-condensing (30% per hour max)
Nonoperating	5% to 95% non-condensing (30% per hour max)

2.7.4.2 Wet bulb temperature

Operating	26°C / 78.8°F (rated)
Non-operating	29°C / 84.2°F (rated)

2.7.5 Altitude

Operating	-304m to 3048m (-1000 ft. to 10,000 ft.)
Non-operating	-304m to 12,192m (-1000 ft. to 40,000+ ft.)

2.7.6 Shock

All shock specifications assume that the drive is mounted securely with the input shock applied at the drive mounting screws. Shock may be applied in the X, Y or Z axis.

2.7.6.1 Operating shock

1TB - 4TB

These drives comply with the performance levels specified in this document when subjected to a maximum operating shock of 80 Gs based on half-sine shock pulses of 2ms during read operations. Shocks should not be repeated more than 2 times per second.

6TB and 8TB

These drives comply with the performance levels specified in this document when subjected to a maximum operating shock of 70 Gs based on half-sine shock pulses of 2ms during read operations. Shocks should not be repeated more than 2 times per second.

2.7.6.2 Non-operating shock

1TB-4TB

The non-operating shock level that the drive can experience without incurring physical damage or degradation in performance when subsequently put into operation is 300 Gs based on a non-repetitive half-sine shock pulse of 2ms duration.

6TB and 8TB

The non-operating shock level that the drive can experience without incurring physical damage or degradation in performance when subsequently put into operation is 250 Gs based on a non-repetitive half-sine shock pulse of 2ms duration.

2.7.7 Vibration

All vibration specifications assume that the drive is mounted securely with the input vibration applied at the drive mounting screws. Vibration may be applied in the X, Y or Z axis. Throughput may vary if improperly mounted.

2.7.7.1 Operating vibration

The maximum vibration levels that the drive may experience while meeting the performance standards specified in this document are specified below.

2Hz to 22Hz	0.25 Gs (Limited displacement)
22Hz to 350Hz	0.50 Gs
350Hz to 500Hz	0.25 Gs

2.7.7.2 Non-operating vibration

The maximum non-operating vibration levels that the drive may experience without incurring physical damage or degradation in performance when subsequently put into operation are specified below.

5Hz to 22Hz	3.0 Gs (Limited displacement)
22Hz to 350Hz	3.0 Gs
350Hz to 500Hz	3.0 Gs

2.8 Acoustics

Drive acoustics are measured as overall A-weighted acoustic sound power levels (no pure tones). All measurements are consistent with ISO document 7779. Sound power measurements are taken under essentially free-field conditions over a reflecting plane. For all tests, the drive is oriented with the cover facing upward.

Note	For seek mode tests, the drive is placed in seek mode only. The number of seeks per second is defined by the following equation: (Number of seeks per second = $0.4 / (\text{average latency} + \text{average access time})$)
-------------	--

Table 7 Fluid Dynamic Bearing (FDB) motor acoustics

	Idle*	Seek
1TB & 2TB models	1.9 bels (typ) 2.0 bels (max)	2.1 bels (typ) 2.2 bels (max)
3TB & 4TB models	2.3 bels (typical) 2.4 bels (max)	2.5 bels (typical) 2.6 bels (max)
6TB & 8TB models	2.7 bels (typical) 2.8 bels (max)	2.8 bels (typical) 2.9 bels (max)

*During periods of drive idle, some offline activity may occur according to the S.M.A.R.T. specification, which may increase acoustic and power to operational levels.

2.8.1 Test for Prominent Discrete Tones (PDTs)

Seagate follows the ECMA-74 standards for measurement and identification of PDTs. An exception to this process is the use of the absolute threshold of hearing. Seagate uses this threshold curve (originated in ISO 389-7) to discern tone audibility and to compensate for the inaudible components of sound prior to computation of tone ratios according to Annex D of the ECMA-74 standards.

2.9 Electromagnetic immunity

When properly installed in a representative host system, the drive operates without errors or degradation in performance when subjected to the radio frequency (RF) environments defined in [Table 8](#).

Table 8 Radio frequency environments

Test	Description	Performance level	Reference standard
Electrostatic discharge	Contact, HCP, VCP: ± 4 kV; Air: ± 8 kV	B	EN61000-4-2: 95
Radiated RF immunity	80MHz to 1,000MHz, 3 V/m, 80% AM with 1kHz sine 900MHz, 3 V/m, 50% pulse modulation @ 200Hz	A	EN61000-4-3: 96 ENV50204: 95
Electrical fast transient	± 1 kV on AC mains, ± 0.5 kV on external I/O	B	EN61000-4-4: 95
Surge immunity	± 1 kV differential, ± 2 kV common, AC mains	B	EN61000-4-5: 95
Conducted RF immunity	150kHz to 80MHz, 3 Vrms, 80% AM with 1kHz sine	A	EN61000-4-6: 97
Voltage dips, interrupts	0% open, 5 seconds 0% short, 5 seconds 40%, 0.10 seconds 70%, 0.01 seconds	C C C B	EN61000-4-11: 94

2.10 Reliability - Mean Time Between Failure

The product will achieve a Mean Time Between Failure Rate (MTBF) of 1,000,000 hours when operated in an environment of ambient air temperatures of 25°C. Operation at temperatures outside the specifications shown in [Section 2.7](#) may decrease the product MTBF. MTBF is a population statistic that is not relevant to individual units.

- MTBF specifications are based on the following assumptions for NAS environments:
- 8760 power-on hours per year
- 10,000 average motor start/stop cycles per year
- Operations at nominal voltages
- Temperatures outside the specifications in [Section 2.7](#) may reduce the product reliability.

Operation at excessive I/O duty cycle may degrade product reliability. The NAS environment of power-on hours, temperature, and I/O duty cycle affect the product MTBF. The MTBF will be degraded if used in an enterprise application.

2.10.1 Storage

Maximum storage periods are 180 days within original unopened Seagate shipping package or 60 days unpackaged within the defined non-operating limits (refer to environmental section in this manual). Storage can be extended to 1 year packaged or unpackaged under optimal environmental conditions (25°C, <40% relative humidity non-condensing, and non-corrosive environment). During any storage period the drive non-operational temperature, humidity, wet bulb, atmospheric conditions, shock, vibration, magnetic and electrical field specifications should be followed.

2.11 Warranty

To determine the warranty for a specific drive, use a web browser to access the following web page:

<http://www.seagate.com/support/warranty-and-replacements/>

From this page, click on "Is my Drive under Warranty". Users will be asked to provide the drive serial number, model number (or part number) and country of purchase. The system will display the warranty information for the drive.

2.12 Agency certification

2.12.1 Safety certification

These products are certified to meet the requirements of UL60950-1, CSA60950-1 and EN60950 and so marked as to the certify agency.

2.12.2 Electromagnetic compatibility

Hard drives that display the CE mark comply with the European Union (EU) requirements specified in the Electromagnetic Compatibility Directive 2004/108/EC (Until 19th April, 2016) and 2014/30/EU (From 20th April, 2016). Testing is performed to the levels specified by the product standards for Information Technology Equipment (ITE). Emission levels are defined by EN 55022, Class B and the immunity levels are defined by EN 55024.

Drives are tested in representative end-user systems. Although CE-marked Seagate drives comply with the directives when used in the test systems, we cannot guarantee that all systems will comply with the directives. The drive is designed for operation inside a properly designed enclosure, with properly shielded I/O cable (if necessary) and terminators on all unused I/O ports. Computer manufacturers and system integrators should confirm EMC compliance and provide CE marking for their products.

Korean RRA

If these drives have the Korean Communications Commission (KCC) logo, they comply with paragraph 1 of Article 11 of the Electromagnetic Compatibility control Regulation and meet the Electromagnetic Compatibility (EMC) Framework requirements of the Radio Research Agency (RRA) Communications Commission, Republic of Korea.

These drives have been tested and comply with the Electromagnetic Interference/Electromagnetic Susceptibility (EMI/EMS) for Class B products. Drives are tested in a representative, end-user system by a Korean-recognized lab.

기종별	사용자안내문
B급 기기 (가정용 방송통신기자재)	이 기기는 가정용(B급) 전자파적합기기로서 주로 가정에서 사용하는 것을 목적으로 하며, 모든 지역에서 사용할 수 있습니다.

Australian RCM Compliance Mark

If these models have the RCM marking, they comply with the Australia/New Zealand Standard AS/NZS CISPR22: 2009 and meet the Electromagnetic Compatibility (EMC) Framework requirements of the Australian Communication and Media Authority (ACMA).

2.12.3 FCC verification

These drives are intended to be contained solely within a personal computer or similar enclosure (not attached as an external device). As such, each drive is considered to be a subassembly even when it is individually marketed to the customer. As a subassembly, no Federal Communications Commission verification or certification of the device is required.

Seagate has tested this device in enclosures as described above to ensure that the total assembly (enclosure, disk drive, motherboard, power supply, etc.) does comply with the limits for a Class B computing device, pursuant to Subpart J, Part 15 of the FCC rules. Operation with non-certified assemblies is likely to result in interference to radio and television reception.

Radio and television interference. This equipment generates and uses radio frequency energy and if not installed and used in strict accordance with the manufacturer's instructions, may cause interference to radio and television reception.

This equipment is designed to provide reasonable protection against such interference in a residential installation. However, there is no guarantee that interference will not occur in a particular installation. If this equipment does cause interference to radio or television, which can be determined by turning the equipment on and off, users are encouraged to try one or more of the following corrective measures:

- Reorient the receiving antenna.
- Move the device to one side or the other of the radio or TV.
- Move the device farther away from the radio or TV.
- Plug the computer into a different outlet so that the receiver and computer are on different branch outlets.

If necessary, users should consult the dealer or an experienced radio/television technician for additional suggestions. Users may find helpful the following booklet prepared by the Federal Communications Commission: *How to Identify and Resolve Radio-Television Interference Problems*. This booklet is available from the Superintendent of Documents, U.S. Government Printing Office, Washington, DC 20402. Refer to publication number 004-000-00345-4.

2.13 Environmental protection

Seagate designs its products to meet environmental protection requirements worldwide, including regulations restricting certain chemical substances.

2.13.1 European Union Restriction of Hazardous Substances (RoHS) Directive

The European Union Restriction of Hazardous Substances (RoHS) Directive, restricts the presence of chemical substances, including Lead, Cadmium, Mercury, Hexavalent Chromium, PBB and PBDE, in electronic products, effective July 2006. This drive is manufactured with components and materials that comply with the RoHS Directive.

2.13.2 China Requirements — China RoHS 2



China RoHS 2 refers to the Ministry of Industry and Information Technology Order No. 32, effective July 1, 2016, titled Management Methods for the Restriction of the Use of Hazardous Substances in Electrical and Electronic Products. To comply with China RoHS 2, we determined this product's Environmental Protection Use Period (EPUP) to be 20 years in accordance with the *Marking for the Restricted Use of Hazardous Substances in Electronic and Electrical Products*, SJT 11364-2014.

Table 9 Hazardous Substances

部件名称 Part Name	有害物质 Hazardous Substances					
	铅 (Pb)	汞 (Hg)	镉 (Cd)	六价铬 (Cr ⁺⁶)	多溴联苯 (PBB)	多溴二苯醚 (PBDE)
印刷电路板组装 PCBA	X	O	O	O	O	O
机壳 Chassis	X	O	O	O	O	O

本表格依据 **SJ/T 11364** 的规定编制。
This table is prepared in accordance with the provisions of SJ/T 11364-2014

O: 表示该有害物质在该部件所有均质材料中的含量均在 **GB/T 26572** 规定的限量要求以下。
O: Indicates that the hazardous substance contained in all of the homogeneous materials for this part is below the limit requirement of GB/T26572.

X: 表示该有害物质至少在该部件的某一均质材料中的含量超出 **GB/T 26572** 规定的限量要求。
X: Indicates that the hazardous substance contained in at least one of the homogeneous materials used for this part is above the limit requirement of GB/T26572.

2.14 Corrosive environment

Seagate electronic drive components pass accelerated corrosion testing equivalent to 10 years exposure to light industrial environments containing sulfurous gases, chlorine and nitric oxide, classes G and H per ASTM B845. However, this accelerated testing cannot duplicate every potential application environment. Users should use caution exposing any electronic components to uncontrolled chemical pollutants and corrosive chemicals as electronic drive component reliability can be affected by the installation environment. The silver, copper, nickel and gold films used in Seagate products are especially sensitive to the presence of sulfide, chloride, and nitrate contaminants. Sulfur is found to be the most damaging. In addition, electronic components should never be exposed to condensing water on the surface of the printed circuit board assembly (PCBA) or exposed to an ambient relative humidity greater than 95%. Materials used in cabinet fabrication, such as vulcanized rubber, that can outgas corrosive compounds should be minimized or eliminated. The useful life of any electronic equipment may be extended by replacing materials near circuitry with sulfide-free alternatives.

3.0 Configuring and Mounting the Drive

This section contains the specifications and instructions for configuring and mounting the drive.

3.1 Handling and static-discharge precautions

After unpacking, and before installation, the drive may be exposed to potential handling and electrostatic discharge (ESD) hazards. Observe the following standard handling and static-discharge precautions:

Caution

- Before handling the drive, put on a grounded wrist strap, or ground oneself frequently by touching the metal chassis of a computer that is plugged into a grounded outlet. Wear a grounded wrist strap throughout the entire installation procedure.
- Handle the drive by its edges or frame *only*.
- The drive is extremely fragile—handle it with care. Do not press down on the drive top cover.
- Always rest the drive on a padded, antistatic surface until mounting it in the computer.
- Do not touch the connector pins or the printed circuit board.
- Do not remove the factory-installed labels from the drive or cover them with additional labels. Removal voids the warranty. Some factory-installed labels contain information needed to service the drive. Other labels are used to seal out dirt and contamination.

3.2 Configuring the drive

Each drive on the SATA interface connects point-to-point with the SATA host adapter. There is no master/slave relationship because each drive is considered a master in a point-to-point relationship. If two drives are attached on one SATA host adapter, the host operating system views the two devices as if they were both “masters” on two separate ports. Both drives behave as if they are Device 0 (master) devices.

SATA drives are designed for easy installation. It is usually not necessary to set any jumpers on the drive for proper operation; however, if users connect the drive and receive a “drive not detected” error, the SATA-equipped motherboard or host adapter may use a chipset that does not support SATA speed autonegotiation.

3.3 SATA cables and connectors

The SATA interface cable consists of four conductors in two differential pairs, plus three ground connections. The cable size may be 30 to 26 AWG with a maximum length of one meter (39.37 inches). See [Table 10](#) for connector pin definitions. Either end of the SATA signal cable can be attached to the drive or host.

For direct backplane connection, the drive connectors are inserted directly into the host receptacle. The drive and the host receptacle incorporate features that enable the direct connection to be hot pluggable and blind mateable.

For installations which require cables, users can connect the drive as illustrated in [Figure 2](#).

Figure 2 Attaching SATA cabling

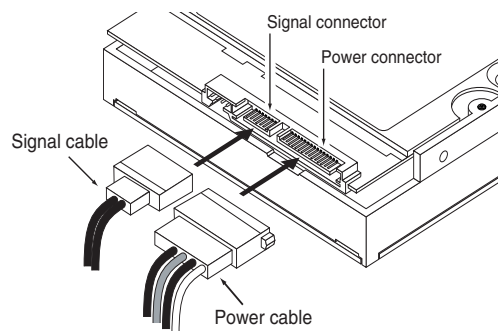

Each cable is keyed to ensure correct orientation. SkyHawk drives support latching SATA connectors.

3.4 Drive mounting

Users can mount the drive in any orientation using four screws in the side-mounting holes or four screws in the bottom-mounting holes. Refer to **Figure 6** for drive mounting dimensions. Follow these important mounting precautions when mounting the drive:

- Allow a minimum clearance of 0.030 inches (0.76mm) around the entire perimeter of the drive for cooling.
- Use only 6-32 UNC mounting screws.
- The screws should be inserted no more than 0.120 inch (3.05mm) into the bottom or side mounting holes.
- Do not overtighten the mounting screws (maximum torque: 6 inch-lb).

Figure 3 Mounting dimensions (8TB)

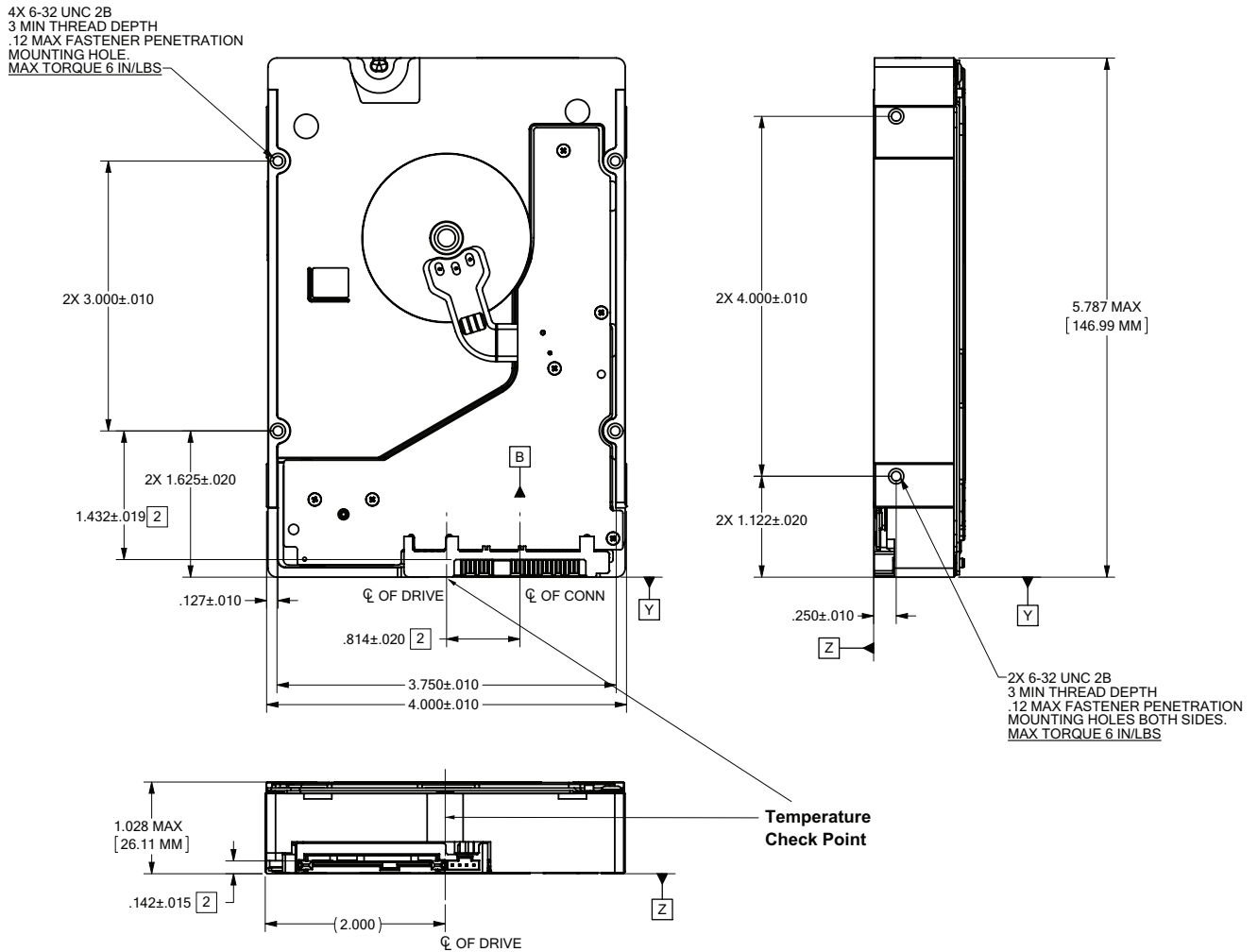

Figure 4 Mounting dimensions (6TB)

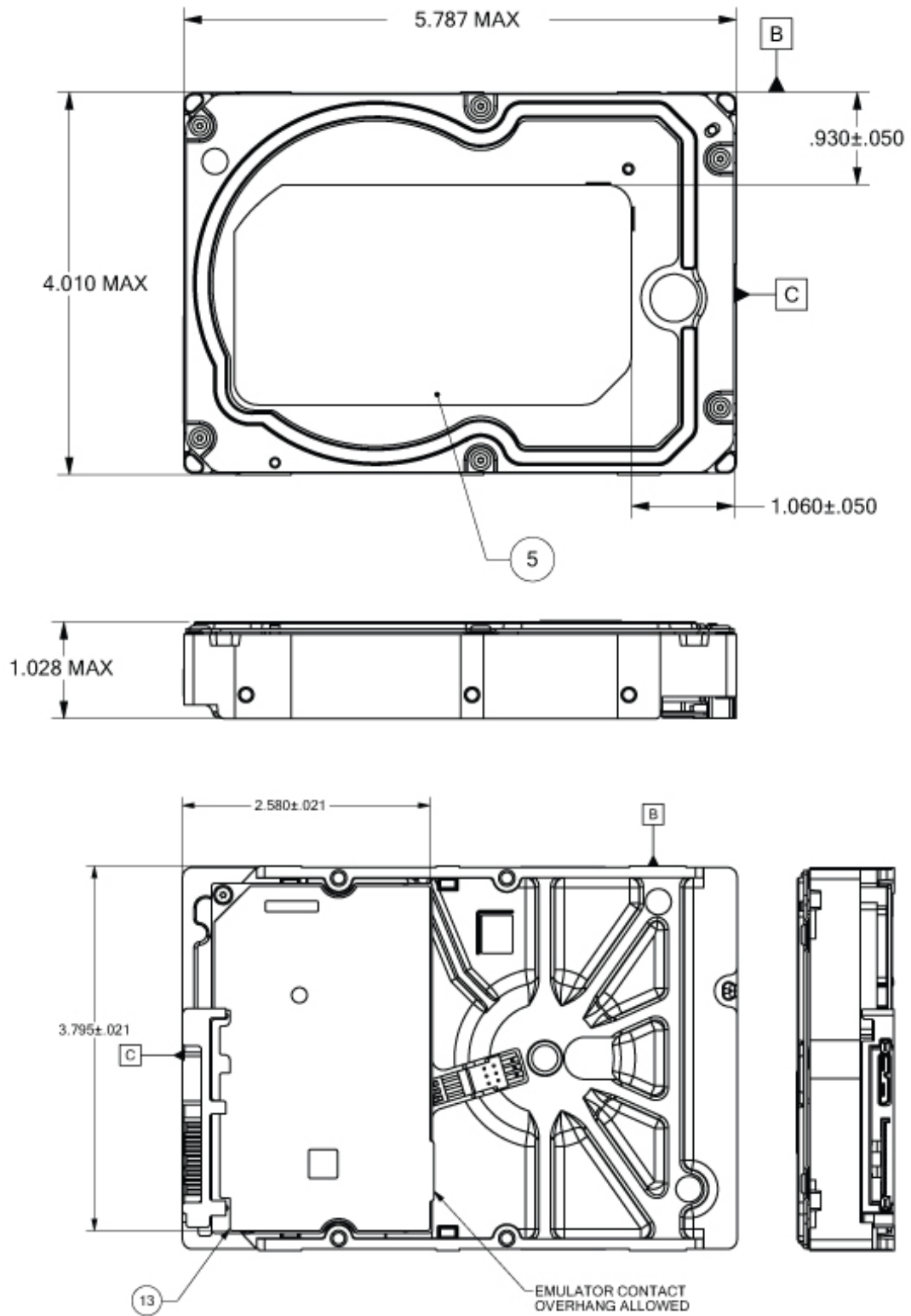

Figure 5 Mounting dimensions (4TB)

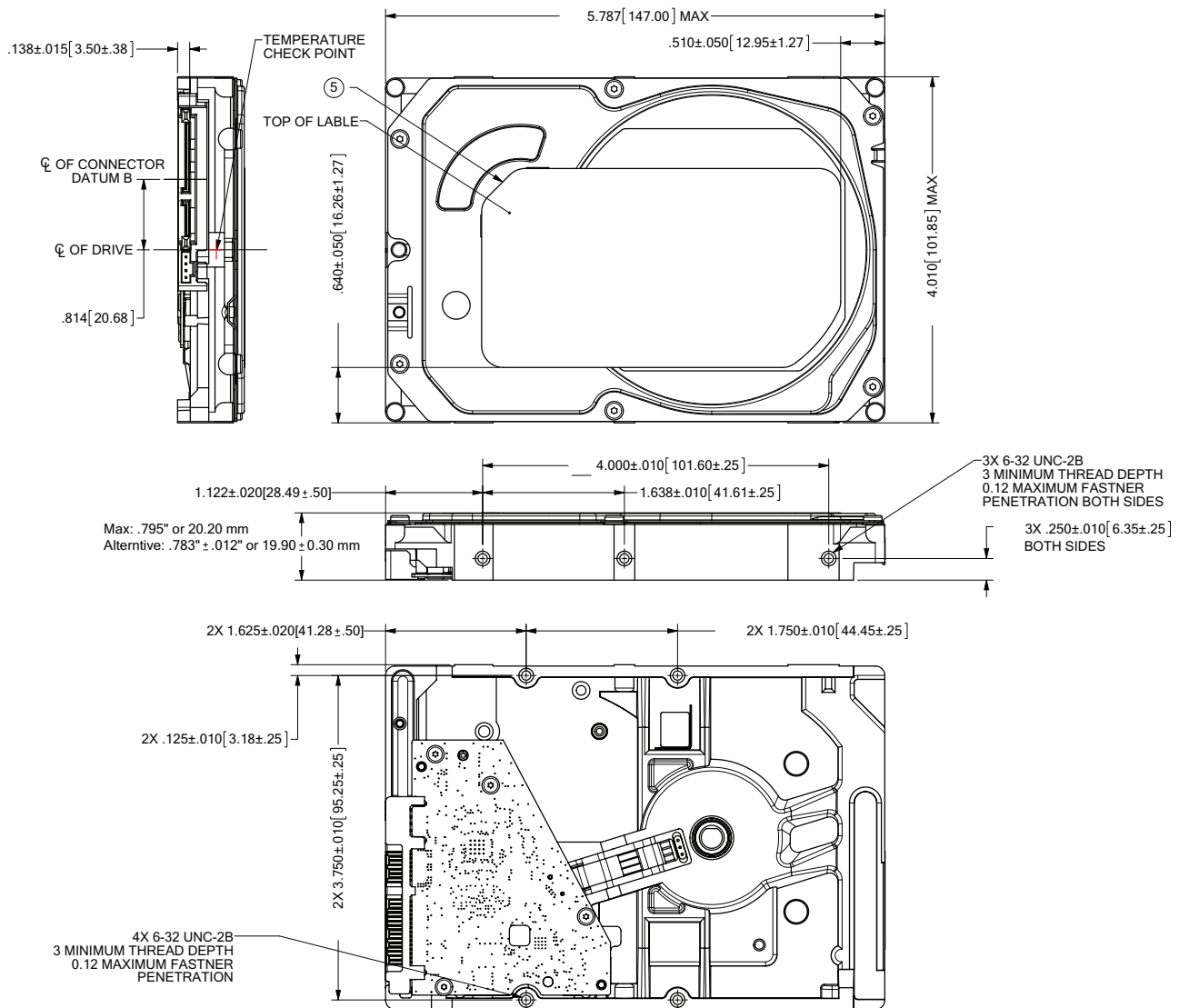

Figure 6 Mounting dimensions (3TB - 2TB)

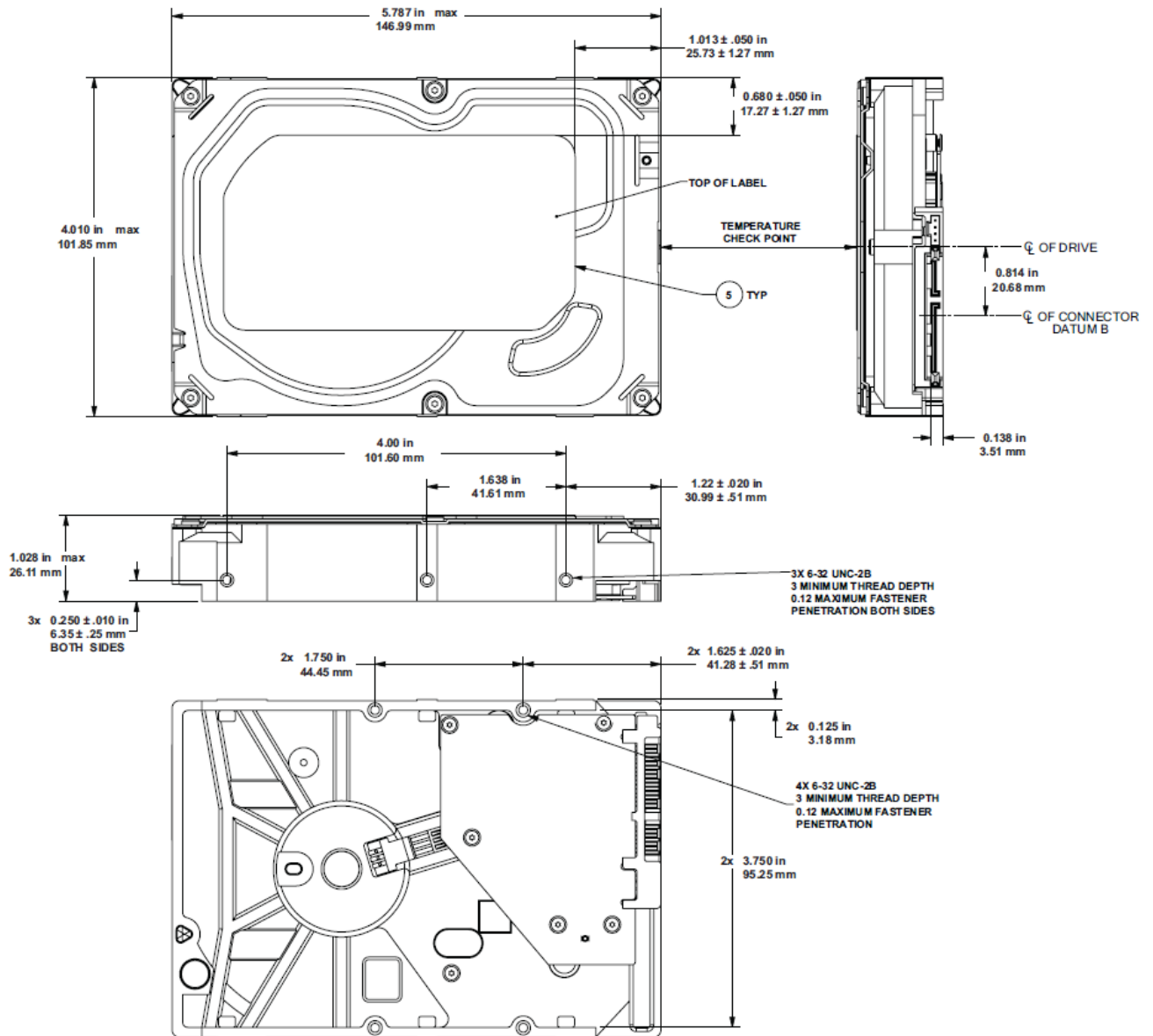
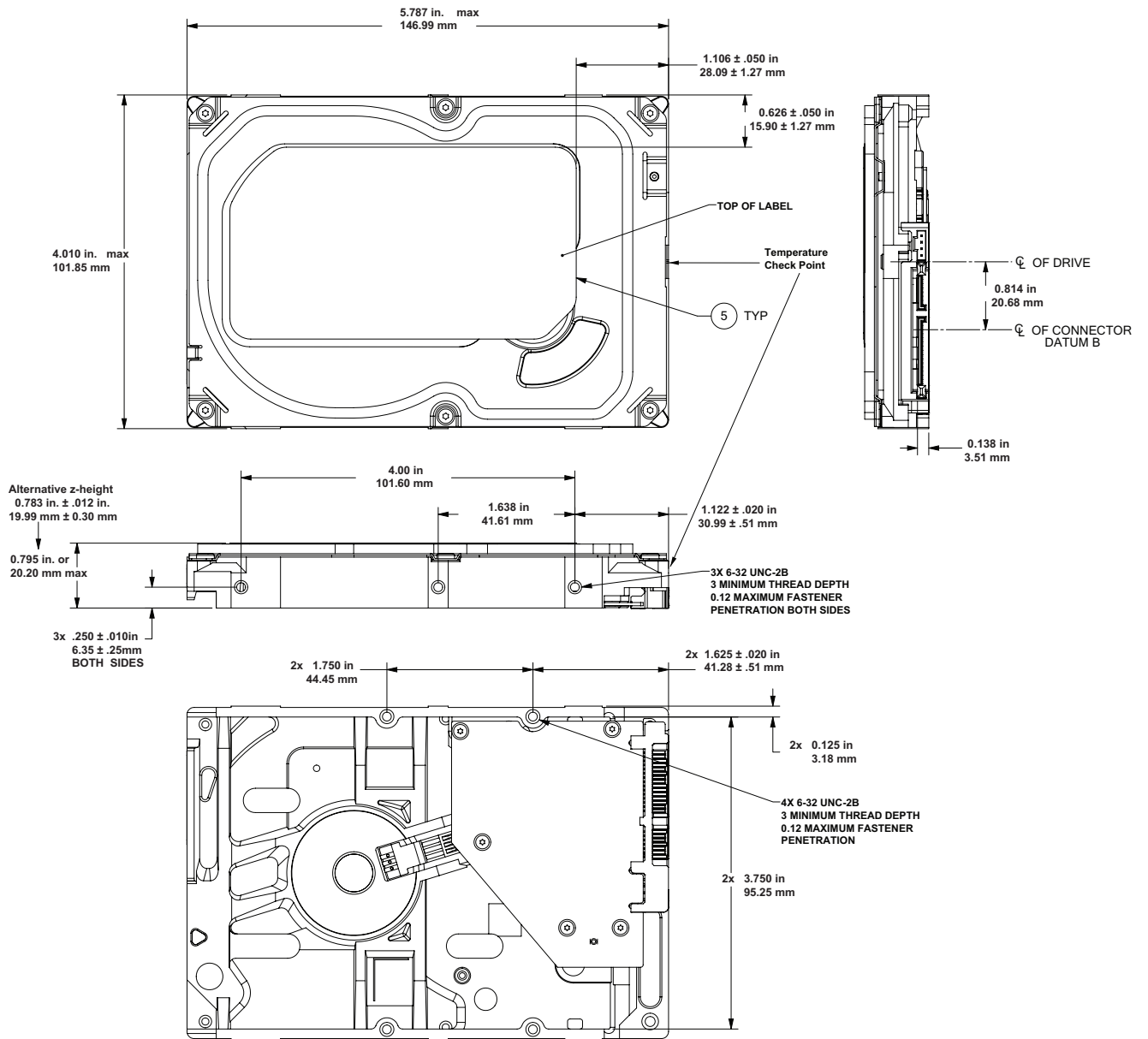

Figure 7 Mounting dimensions (1TB)



4.0 SATA Interface

These drives use the industry-standard Serial ATA (SATA) interface that supports FIS data transfers. It supports ATA programmed input/output (PIO) modes 0 to 4; multiword DMA modes 0 to 2, and Ultra DMA modes 0 to 6.

For detailed information about the SATA interface, refer to the “Serial ATA: High Speed Serialized AT Attachment” specification.

4.1 Hot-Plug compatibility

SkyHawk drives incorporate connectors which enable users to hot plug these drives in accordance with the SATA Revision 3.2 specification. This specification can be downloaded from www.serialata.org.

4.2 SATA device plug connector pin definitions

Table 10 summarizes the signals on the SATA interface and power connectors.

Table 10 SATA connector pin definitions

Segment	Pin	Function	Definition
Signal	S1	Ground	2nd mate
	S2	A+	Differential signal pair A from Phy
	S3	A-	
	S4	Ground	2nd mate
	S5	B-	Differential signal pair B from Phy
	S6	B+	
	S7	Ground	2nd mate
Key and spacing separate signal and power segments			
Power	P1	V ₃₃	3.3V power
	P2	V ₃₃	3.3V power
	P3	V ₃₃	3.3V power, pre-charge, 2nd mate
	P4	Ground	1st mate
	P5	Ground	2nd mate
	P6	Ground	2nd mate
	P7	V ₅	5V power, pre-charge, 2nd mate
	P8	V ₅	5V power
	P9	V ₅	5V power
	P10	Ground	2nd mate
	P11	Ground or LED signal	If grounded, drive does not use deferred spin
	P12	Ground	1st mate.
	P13	V ₁₂	12V power, pre-charge, 2nd mate
	P14	V ₁₂	12V power
	P15	V ₁₂	12V power

Notes

- All pins are in a single row, with a 1.27 mm (0.050 in) pitch.
- The comments on the mating sequence apply to the case of backplane blindmate connector only. In this case, the mating sequences are:
 - the ground pins P4 and P12.
 - the pre-charge power pins and the other ground pins.
 - the signal pins and the rest of the power pins.
- There are three power pins for each voltage. One pin from each voltage is used for pre-charge when installed in a blind-mate backplane configuration.
 - All used voltage pins (V_x) must be terminated.

4.3 Supported ATA commands

The following table lists SATA standard commands that the drive supports.

For a detailed description of the ATA commands, refer to the Serial ATA International Organization: Serial ATA Revision 3.2 (<http://www.sata-io.org>).

See “S.M.A.R.T. commands” on page 36 for details and subcommands used in the S.M.A.R.T. implementation.

Table 11 SATA standard commands

Command name	Command code (in hex)
Check Power Mode	E5 _H
Device Configuration Freeze Lock	B1 _H / C1 _H
Device Configuration Identify	B1 _H / C2 _H
Device Configuration Restore	B1 _H / C0 _H
Device Configuration Set	B1 _H / C3 _H
Device Reset	08 _H
Download Microcode	92 _H
Execute Device Diagnostics	90 _H
Flush Cache	E7 _H
Flush Cache Extended	EA _H
Format Track	50 _H
Identify Device	EC _H
Idle	E3 _H
Idle Immediate	E1 _H
Initialize Device Parameters	91 _H
Read Buffer	E4 _H
Read DMA	C8 _H
Read DMA Extended	25 _H
Read DMA Without Retries	C9 _H
Read Log Ext	2F _H
Read Multiple	C4 _H
Read Multiple Extended	29 _H
Read Native Max Address	F8 _H
Read Native Max Address Extended	27 _H
Read Sectors	20 _H
Read Sectors Extended	24 _H
Read Sectors Without Retries	21 _H
Read Verify Sectors	40 _H
Read Verify Sectors Extended	42 _H
Read Verify Sectors Without Retries	41 _H
Recalibrate	10 _H
Security Disable Password	F6 _H
Security Erase Prepare	F3 _H
Security Erase Unit	F4 _H
Security Freeze	F5 _H
Security Set Password	F1 _H
Security Unlock	F2 _H
Seek	70 _H

Table 11 SATA standard commands (continued)

Command name	Command code (in hex)	
Set Features	EF _H	
Set Max Address	F9 _H	
Note: Individual Set Max Address commands are identified by the value placed in the Set Max Features register as defined to the right.	Address:	00 _H
	Password:	01 _H
	Lock:	02 _H
	Unlock:	03 _H
	Freeze Lock:	04 _H
Set Max Address Extended	37 _H	
Set Multiple Mode	C6 _H	
Sleep	E6 _H	
S.M.A.R.T. Disable Operations	B0 _H / D9 _H	
S.M.A.R.T. Enable/Disable Autosave	B0 _H / D2 _H	
S.M.A.R.T. Enable Operations	B0 _H / D8 _H	
S.M.A.R.T. Execute Offline	B0 _H / D4 _H	
S.M.A.R.T. Read Attribute Thresholds	B0 _H / D1 _H	
S.M.A.R.T. Read Data	B0 _H / D0 _H	
S.M.A.R.T. Read Log Sector	B0 _H / D5 _H	
S.M.A.R.T. Return Status	B0 _H / DA _H	
S.M.A.R.T. Save Attribute Values	B0 _H / D3 _H	
S.M.A.R.T. Write Log Sector	B0 _H / D6 _H	
Standby	E2 _H	
Standby Immediate	E0 _H	
Write Buffer	E8 _H	
Write DMA	CA _H	
Write DMA Extended	35 _H	
Write DMA FUA Extended	3D _H	
Write DMA Without Retries	CB _H	
Write Log Extended	3F _H	
Write Multiple	C5 _H	
Write Multiple Extended	39 _H	
Write Multiple FUA Extended	CE _H	
Write Sectors	30 _H	
Write Sectors Without Retries	31 _H	
Write Sectors Extended	34 _H	
Write Uncorrectable	45 _H	

4.3.1 Identify Device command

The Identify Device command (command code EC_H) transfers information about the drive to the host following power up. The data is organized as a single 512-byte block of data, whose contents are shown in on page 29. All reserved bits or words should be set to zero. Parameters listed with an “x” are drive-specific or vary with the state of the drive.

The following commands contain drive-specific features that may not be included in the SATA specification.

Table 12 Identify Device commands

Word	Description	Value
0	Configuration information: • Bit 15: 0 = ATA; 1 = ATAPI • Bit 7: removable media • Bit 6: removable controller • Bit 0: reserved	0C5A _H
1	Number of logical cylinders	16,383
2	ATA-reserved	0000 _H
3	Number of logical heads	16
4	Retired	0000 _H
5	Retired	0000 _H
6	Number of logical sectors per logical track: 63	003F _H
7–9	Retired	0000 _H
10–19	Serial number: (20 ASCII characters, 0000 _H = none)	ASCII
20	Retired	0000 _H
21	Retired	0400 _H
22	Obsolete	0000 _H
23–26	Firmware revision (8 ASCII character string, padded with blanks to end of string)	x.xx
27–46	Drive model number: (40 ASCII characters, padded with blanks to end of string)	
47	(Bits 7–0) Maximum sectors per interrupt on Read multiple and Write multiple (16)	8010 _H
48	Reserved	0000 _H
49	Standard Standby timer, IORDY supported and may be disabled	2F00 _H
50	ATA-reserved	0000 _H
51	PIO data-transfer cycle timing mode	0200 _H
52	Retired	0200 _H
53	Words 54–58, 64–70 and 88 are valid	0007 _H
54	Number of current logical cylinders	xxxx _H
55	Number of current logical heads	xxxx _H
56	Number of current logical sectors per logical track	xxxx _H
57–58	Current capacity in sectors	xxxx _H
59	Number of sectors transferred during a Read Multiple or Write Multiple command	xxxx _H

Table 12 Identify Device commands (continued)

Word	Description	Value
60–61	Total number of user-addressable LBA sectors available (see Section 2.2 for related information) *Note: The maximum value allowed in this field is: 0FFFFFFFh (268,435,455 sectors, 137GB). Drives with capacities over 137GB will have 0FFFFFFFh in this field and the actual number of user-addressable LBAs specified in words 100-103. This is required for drives that support the 48-bit addressing feature.	0FFFFFFFh*
62	Retired	0000 _H
63	Multiword DMA active and modes supported (see note following this table)	xx07 _H
64	Advanced PIO modes supported (modes 3 and 4 supported)	0003 _H
65	Minimum multiword DMA transfer cycle time per word (120 nsec)	0078 _H
66	Recommended multiword DMA transfer cycle time per word (120 nsec)	0078 _H
67	Minimum PIO cycle time without IORDY flow control (240 nsec)	0078 _H
68	Minimum PIO cycle time with IORDY flow control (120 nsec)	0078 _H
69–74	ATA-reserved	0000 _H
75	Queue depth	001F _H
76	SATA capabilities	xxxx _H
77	Reserved for future SATA definition	xxxx _H
78	SATA features supported	xxxx _H
79	SATA features enabled	xxxx _H
80	Major version number	01F0 _H
81	Minor version number	0028 _H
82	Command sets supported	364B _H
83	Command sets supported	7F09 _H
84	Command sets support extension (see note following this table)	4163 _H
85	Command sets enabled	30xx _H
86	Command sets enabled	BE09 _H
87	Command sets enable extension	4163 _H
88	Ultra DMA support and current mode (see note following this table)	xx7F _H
89	Security erase time	0039 _H
90	Enhanced security erase time	0039 _H
92	Master password revision code	FFFE _H
93	Hardware reset value	xxxx _H
94	Automatic acoustic management	8080 _H
95	Stream Min. Request Size	0000 _H
96	Streaming Transfer Time - DMA	0000 _H
97	Streaming Access Latency - DMA and PIO	0000 _H
98–99	Streaming Performance Granularity	2710 _H /0000 _H

Table 12 Identify Device commands (continued)

Word	Description	Value
100–103	Total number of user-addressable LBA sectors available (see Section 2.2 for related information). These words are required for drives that support the 48-bit addressing feature. Maximum value: 0000FFFFFFFFFh.	ST1000VX005 = 1,953,525,168 ST2000VX008 = 3,907,029,168 ST3000VX010 = 5,860,533,168 ST4000VX007 = 7,814,037,168 ST6000VX0023 = 11,721,045,168 ST8000VX0022 = 15,628,053,168
104	Streaming Transfer Time - PIO	0000 _H
105–107	ATA-reserved	0000 _H
108–111	The mandatory value of the world wide name (WWN) for the drive. NOTE: This field is valid if word 84, bit 8 is set to 1 indicating 64-bit WWN support.	Each drive will have a unique value.
112–127	ATA-reserved	0000 _H
128	Security status	0001 _H
129–159	Seagate-reserved	xxxx _H
160–254	ATA-reserved	0000 _H
255	Integrity word	xxA5 _H

Note

Advanced Power Management (APM) and Automatic Acoustic Management (AAM) features are not supported.

Note

See the bit descriptions below for words 63, 84, and 88 of the Identify Drive data.

Description (if bit is set to 1)	
Bit	Word 63
0	Multiword DMA mode 0 is supported.
1	Multiword DMA mode 1 is supported.
2	Multiword DMA mode 2 is supported.
8	Multiword DMA mode 0 is currently active.
9	Multiword DMA mode 1 is currently active.
10	Multiword DMA mode 2 is currently active.
Bit	Word 84
0	SMART error login is supported.
1	SMART self-test is supported.
2	Media serial number is supported.
3	Media Card Pass Through Command feature set is supported.
4	Streaming feature set is supported.
5	GPL feature set is supported.
6	WRITE DMA FUA EXT and WRITE MULTIPLE FUA EXT commands are supported.
7	WRITE DMA QUEUED FUA EXT command is supported.
8	64-bit World Wide Name is supported.
9-10	Obsolete.
11-12	Reserved for TLC.
13	IDLE IMMEDIATE command with IUNLOAD feature is supported.
14	Shall be set to 1.
15	Shall be cleared to 0.
Bit	Word 88
0	Ultra DMA mode 0 is supported.
1	Ultra DMA mode 1 is supported.
2	Ultra DMA mode 2 is supported.
3	Ultra DMA mode 3 is supported.
4	Ultra DMA mode 4 is supported.
5	Ultra DMA mode 5 is supported.
6	Ultra DMA mode 6 is supported.
8	Ultra DMA mode 0 is currently active.
9	Ultra DMA mode 1 is currently active.
10	Ultra DMA mode 2 is currently active.
11	Ultra DMA mode 3 is currently active.
12	Ultra DMA mode 4 is currently active.
13	Ultra DMA mode 5 is currently active.
14	Ultra DMA mode 6 is currently active.

4.3.2 Set Features command

This command controls the implementation of various features that the drive supports. When the drive receives this command, it sets BSY, checks the contents of the Features register, clears BSY and generates an interrupt. If the value in the register does not represent a feature that the drive supports, the command is aborted. Power-on default has the read look-ahead and write caching features enabled. The acceptable values for the Features register are defined as follows:

Table 13 Set Features commands

02 _H	Enable write cache (<i>default</i>).
03 _H	Set transfer mode (based on value in Sector Count register). Sector Count register values:
	00 _H Set PIO mode to default (PIO mode 2).
	01 _H Set PIO mode to default and disable IORDY (PIO mode 2).
	08 _H PIO mode 0
	09 _H PIO mode 1
	0A _H PIO mode 2
	0B _H PIO mode 3
	0C _H PIO mode 4 (<i>default</i>)
	20 _H Multiword DMA mode 0
	21 _H Multiword DMA mode 1
	22 _H Multiword DMA mode 2
	40 _H Ultra DMA mode 0
	41 _H Ultra DMA mode 1
	42 _H Ultra DMA mode 2
	43 _H Ultra DMA mode 3
	44 _H Ultra DMA mode 4
	45 _H Ultra DMA mode 5
	46 _H Ultra DMA mode 6
06 _H	Enable the PUIS feature set
07 _H	PUIS feature set device spin-up
10 _H	Enable use of SATA features
55 _H	Disable read look-ahead (read cache) feature
82 _H	Disable write cache
86 _H	Disable the PUIS feature set
90 _H	Disable use of SATA features
AA _H	Enable read look-ahead (read cache) feature (<i>default</i>).
F1 _H	Report full capacity available

Note

At power-on, or after a hardware or software reset, the default values of the features are as indicated above.

4.3.3 S.M.A.R.T. commands

S.M.A.R.T. provides near-term failure prediction for disk drives. When S.M.A.R.T. is enabled, the drive monitors predetermined drive attributes that are susceptible to degradation over time. If self-monitoring determines that a failure is likely, S.M.A.R.T. makes a status report available to the host. Not all failures are predictable. S.M.A.R.T. predictability is limited to the attributes the drive can monitor. For more information on S.M.A.R.T. commands and implementation, see the *Draft ATA-5 Standard*.

SeaTools diagnostic software activates a built-in drive self-test (DST S.M.A.R.T. command for D4_H) that eliminates unnecessary drive returns. The diagnostic software ships with all new drives and is also available at: <http://seatools.seagate.com>.

This drive is shipped with S.M.A.R.T. features enabled. **Table 14** below shows the S.M.A.R.T. command codes that the drive uses.

Table 14 S.M.A.R.T. commands

Code in features register	S.M.A.R.T. command
D0 _H	S.M.A.R.T. Read Data
D2 _H	S.M.A.R.T. Enable/Disable Attribute Autosave
D3 _H	S.M.A.R.T. Save Attribute Values
D4 _H	S.M.A.R.T. Execute Off-line Immediate (runs DST)
D5 _H	S.M.A.R.T. Read Log Sector
D6 _H	S.M.A.R.T. Write Log Sector
D8 _H	S.M.A.R.T. Enable Operations
D9 _H	S.M.A.R.T. Disable Operations
DA _H	S.M.A.R.T. Return Status

Note

If an appropriate code is not written to the Features Register, the command is aborted and 0x04 (abort) is written to the Error register.



Seagate Technology LLC

AMERICAS Seagate Technology LLC 10200 South De Anza Boulevard, Cupertino, California 95014, United States, 408-658-1000

ASIA/PACIFIC Seagate Singapore International Headquarters Pte. Ltd. 7000 Ang Mo Kio Avenue 5, Singapore 569877, 65-6485-3888

EUROPE, MIDDLE EAST AND AFRICA Seagate Technology SAS 16-18 rue du Dôme, 92100 Boulogne-Billancourt, France, 33 1-4186 10 00