



# Handheld Video Stabilizer

---

## INSTRUCTION MANUAL



For Demonstration only

All rights reserved

No part of this document may be reproduced, stored in a retrieval system, or transmitted by any form or by any means, electronic, mechanical, photocopying, recording, or otherwise, except as may be expressly permitted by the applicable copyright statutes or in writing by the publisher.

## INTRODUCTION

Your Flycam comes unassembled. This step-by-step user's guide is designed to show how to assemble, maintain and use your new . Properly cared for it should provide years of service while adding a dimension to your work that is sure to please.

## IN THE BOX

Please inspect the contents of your shipped package to ensure you have received all that is pictured and listed below.

**Note:** 1. If you have purchased Flycam 5000 (FLCM-5000-Q), you will receive all the items mentioned below:



**Note:** 2. If you have purchased Flycam 3000 (FLCM-3000-Q), you will receive all the items mentioned above (Except of Table Clamp) :

### HEAD ASSEMBLY

- Head Plate
- Mid Plate
- Bottom Plate

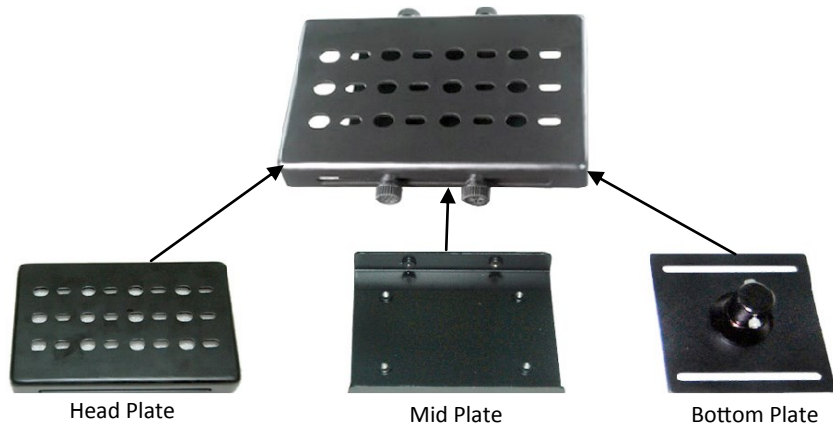

These three individual pieces are shipped as one assembled unit.

### ‘V’ SHAPED ADAPTORS INCLUDED IN HARDWARE KIT

**Note:** Included in the hardware package are two different sized V-shaped adaptors used to attach the camera to the head plate. Choose the one that is suitable for your camera. A locking pin located at the front of the adaptor prevents camera rotation on the head.



**Note:** If you have purchased Flycam-5000 (FLCM-5000-Q) then you will receive 4pc ‘V’ shaped adaptors.

If you have purchased Flycam3000 (FLCM-3000-Q) then you will receive 2pc small ‘V’ shaped adaptors.

### UNICO QUICK RELEASE PLATE AND ADAPTRER



### CENTRAL POST

**Warning:** The Gimbaled control unit, handle and yoke have been factory set for optimum performance.

**Do not attempt to adjust them.**



**Note:** The threaded stud is located in the center of the base plate for attach it with central post.



## ASSEMBLING YOUR FLYCAM HANDHELD VIDEO STABILIZER

**Note:** Assembling steps are same for both Stabilizers.

**Note:** Included in the hardware package are two different sized V-shaped adaptors used to attach the camera to the head plate. Choose the one that is suitable for your camera. A locking pin located at the front of the adaptor prevents camera rotation on the head.



## ATTACHING THE HEAD PLATE ASSEMBLY TO THE CENTRAL POST

- Loosen the 2x allen bolts at the bottom of camera plate, align the holes with the top of the central post & retighten the allen bolts securing the head to the stalk.



- Remove the head plate by unscrewing the four side knobs to mount the quick release adaptor.



- Loosen the allen bolt at the bottom of the quick release adapter and attach it to the head plate.



- Attach the head plate to the FLYCAM with appropriate fore & aft positioning and tighten the side knobs as shown. Further 'fine tuning' will probably be required.



- Open the lever and remove quick release plate from quick release adapter. Then attach it with your camera with the help of screw driver.



- Insert your camera setup with quick release plate into quick release adapter and tightened with provided lever.



Should you wish to bypass the quick release plate, the camera can be directly attached to the Head Plate by using following assembly sequence:

- Remove the Head plate from the 3-piece head assembly in preparation to attach it to your camera. You will note a number of mounting holes that can be used to adapt to various cameras.

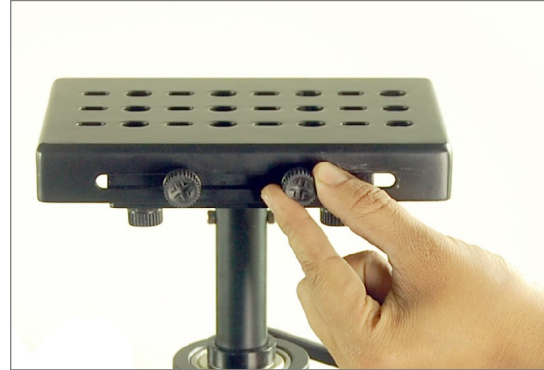

- Center the Head Plate on the camera and secure it properly.

**Do not over tighten this adjustment as it can break the threaded insert.**



- Align the camera center of balance to the mid plate and secure.



- The many slots located on the head plate and bottom plate allow you to easily adjust the X & Y axis for perfect balance. Once achieved, tighten the knobs to secure. Further 'fine tuning' will probably be required.

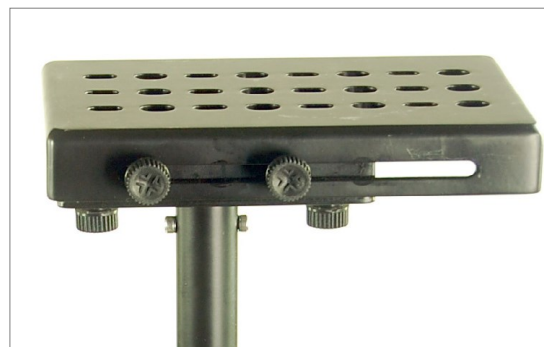
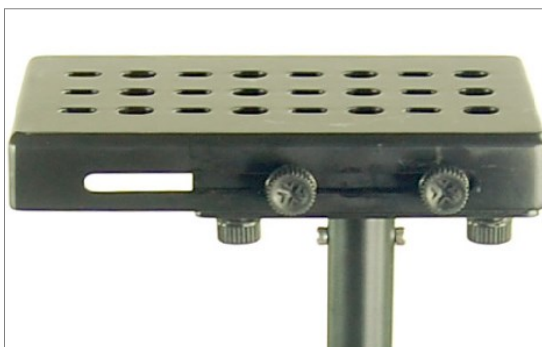

**Head Plate X adjustment**

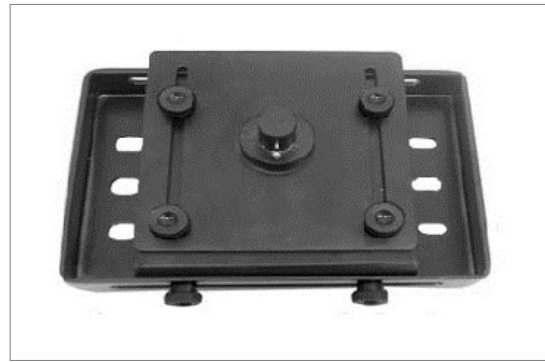
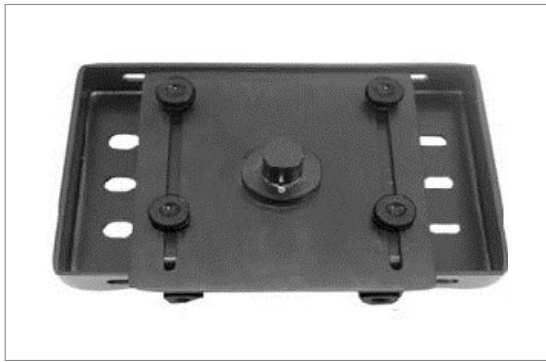

**Head Plate Y adjustment**

- Place the assembly in line with the center of the stabilizer stalk and tighten the side adjusters as shown. Further 'fine tuning' will probably be required.

**If you wish to use table clamp then please use following sequence of pictures and text.**

- Attach clamp onto the table, tighten the provided knob to secure. Then attach handle onto the clamp, it helps achieving balance in just seconds and saves your professional time.



**YOUR FLYCAM HANDHELD STABILIZER  
ALL DRESSED UP AND READY TO GO**



**Exclusive of Camera**

## ADDING WEIGHTS AND POSITIONING FOR PROPER BALANCE

Continuing the assembly and balance requirements to make your Flycam Handheld Video Stabilizer fully functional you will note that the base platform has a provision to mount the balance weights in their cups via a slot found on both sides of the post.

The purpose of the counter weight system is to match the low end of the stabilizer to the weight of the camera and accessories at the high/top end with the gimbaled handle as the pivot point in between. The heavier the camera and accessories, the more weights are required to achieve proper balance. Generally as you add weight to one side of the central post, an equal amount has to be added to the other side to maintain horizontal balance. However if you are using an offset configuration such as a flip out viewfinder or off center accessories, extra weights might be needed on the opposite side of the post to counter act and maintain proper balance.

Total weight fixed to the base platform should be equal to the weight of your camera plus the head and any accessories.

**Horizontal adjustment** on the base platform is made by loosening the retaining screws and moving the mounted cups closer to or further away from the stalk and then retightening. You will probably need to adjust and re adjust the horizontal position to achieve optimum performance/personal preference.



**Note:** When adding weight in the cups, use the supplied foam spacers as silencers to prevent metal to metal washer noise.



### VERTICAL STALK ADJUSTMENT

The up and down (vertical) position of the telescopic central post is adjusted by loosening the control located at the base, raising or lowering the stalk to the desired location and then retightening the vertical control.

**Do not over-tighten this control.**



### BALANCING YOUR FLYCAM HANDHELD VIDEO STABILIZER

Before beginning the balancing process check the following

- Camera is securely attached to head plate.
- Lens cap has been removed and secured.
- Telescoping clamp has been tightened.
- Weight discs are added successfully.
- All screws are tightened securely.
- Battery, all accessories and cables should be secured.

### BALANCING THE HORIZONTAL AXIS

When your Flycam Handheld Video Stabilizer is properly assembled, you can start the test and setup of the horizontal balance. Horizontal balance allows the camera to remain level during operation with the Central Post in a vertical position unless off axis framing is desired.

When testing for horizontal balance start from a flat and level surface like a table. This will allow the Flycam Handheld Video Stabilizer to hang freely as you hold it. If your Flycam Handheld Video Stabilizer is correctly balanced on its horizontal axis, then it will be both level & upright, with the Central Post in a perfect vertical position.

**Warning:** If you do not have enough weight on the Base Platform the entire Flycam could flip upside down. Should this movement start to happen be ready to catch the stalk before a complete 180 occurs. This type of unwanted movement requires more weight to be added to the base with additional weight discs.

Another way to accomplish horizontal balance is to move the center of gravity of the camera by re-bolting the camera to a different area of the Head and Mid Plate, either front to back or side to side.

Should the Flycam Handheld Video Stabilizer be front heavy, loosen the screws on the sides of the Head Plate and gently slide the Head Plate back until optimum balance is achieved.

Tilting to the back means the load is tail heavy requiring the plate to be adjusted forward on the head.

**Always secure the screws after any adjustments.**

If you cannot achieve front to back axis balance with this method, then try remounting your camera to a different hole on the Head Plate. Having achieved horizontal balance for the front to back axis, tighten the screws on the Head Plate.

If the Flycam Handheld Video Stabilizer leans to the right, then loosen the screws on the

bottom of the Bottom Plate and then gently slide the Mid Plate to the left. If it leans to the left from the operator's point of view, then adjust the Mid Plate to the right. A bit at a time until balance is achieved.

**Secure all parts after adjustments are made.**

It may be necessary to reconfigure front to back adjustments once correct side-to-side fine-tuning has been accomplished.

Another option to consider is moving the Counter Weight cups back & forth on the Base Platform by sliding them either closer to or further away from the Center Post via the built in base slots. Make sure to tighten the cups down should you move them.

**BALANCING THE VERTICAL AXIS**

The sled should be tied up to the docking adapter of your stand or similar so that you can start the fore & aft balancing adjustments by centering the camcorder over the central post. To do this

- Loosen the side screws of the head plate and the bottom screws of the bottom plate. Look at the Flycam Handheld Video Stabilizer from the side. If the camcorder lens is tipped up or down, move the camcorder forward or backwards until the center of balance is situated over the central post.
- Then, look at the Flycam Handheld Video Stabilizer from the front. If the post is not vertical, adjust the bottom plate until the center post is vertical.
- You can also adjust the weight cups closer to & further away from the sled as per the requirement till the post is straight up and down.

The stability of the Flycam Handheld Video Stabilizer depends on it being slightly bottom heavy. If it is top heavy, it will tilt more. If bottom heavy, it will be sluggish and hard to aim.

Slightly bottom heavy, it will be both stable and easier to control.

Check the vertical balance by using this drop time test

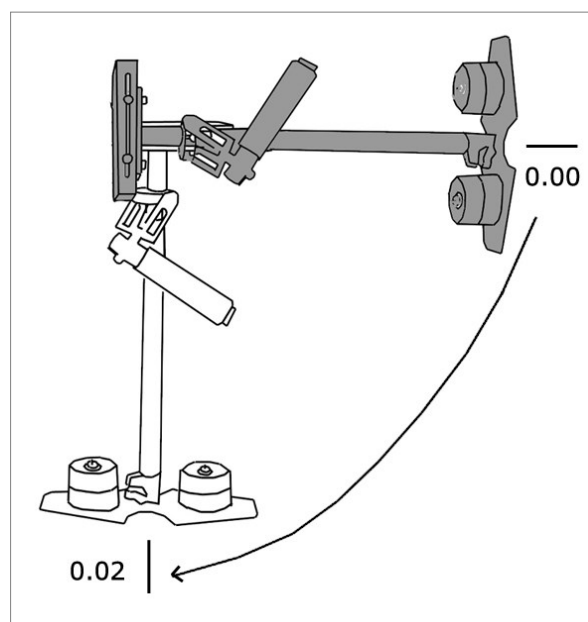

- Make sure that everything is tight and position yourself behind the stand.
- Grasp the center post near the base and move the center post from vertical to horizontal.

- Hold it there. Be sure that it will not hit the stand when you drop the center post and put your free hand to catch the center post when it drops.
- Count how many seconds it will take to fall to vertical. Try using a stopwatch.
- If the drop time is less than 2 seconds, it is too bottom heavy. You need to move the bottom mass closer to the post.
- If the drop time is more than two seconds, it is top heavy.

### **A DROP TIME OF 2 - 2.5 SECONDS IS PREFERRED.**

***Note:** Recheck the balance by looking at the sled. If necessary, use the side screws and the bottom plate screws to make required adjustments.*

## **BALANCING REVIEW**

Proper system balance can only be achieved once your camera is set up with the appropriate accessories ready for shooting. This means batteries, lenses, media cards, LCD viewfinder/monitor, quick release plate, on-cam lights, and all the gear you will use for your recording session.

- Remove the top plate of the Flycam and line up your camera so that its center of gravity is as close to the center of the plate as possible (basically hold the camera in your hand until it feels balanced both left and right as well as forward and back).
- Find the hole in the plate that is as close to the threaded tripod mount on your camera as possible (while you are still holding your camera's center of gravity to the center of the plate). Attach your camera (or quick release mount if you have one). Tighten it down so it won't accidentally rotate.
- Re-attach the top plate to the Flycam. Center it, but don't worry about getting it absolutely perfect yet.
- Remove most of the weights from the Base Platform, but leave one on each side.
- Insert the center post as far as it will go and tighten so it won't slide out.
- Hold the handle normally and turn the Flycam Handheld Video Stabilizer so that it is horizontal to the ground. Let go of the stalk while keeping a firm grip on the handle and count how long it takes to return to vertical again. You should be able to count a good, "One-one thousand, two-one thousand", before it rights itself. With only two little weights it might take considerably longer.
- Add one pair of weights at a time and repeat the "horizontal to vertical" test until it falls at the correct rate. It will probably not be perfect.
- You'll get one that's too slow and then you'll add a pair and it will fall too fast. When that happens, take off the last pair of weights that you added.
- Tighten down the weights so they don't slide around.
- To get the count perfect, slightly lower the center post that attaches the Base Platform with the weights until you get the "one-one thousand, two one thousand" count to the vertical position.
- Fine-tune the left-right, forward-backward balance. You will have to go back and forth between the two directions to get the balance just right. Loosen the screw sets that allow the sled to move left and right. Adjust the top plate so that it is centered and tighten down the screws like you would a tire slowly and alternating side to side.
- Repeat for "forward-backward" balancing.
- Check to see if your camera is sitting level. If not, repeat the necessary steps until it does.
- Practice walking/movements ensuring your body motion is not transmitted to your hands and then the Flycam and camera.

## HOLDING THE FLYCAM HANDHELD VIDEO STABILIZER

When handling your Handheld Video Stabilizer one hand holds onto the handle while the other is used to gently guide the camera in the direction you wish to shoot and frame the shot.

For normal shooting, hold the handle in the middle.

For shots that require framing the camera up, down or sideways, hold the handle firmly at the bottom.

This will allow the “yoke” part of the gimbal to rotate without hitting your hand or knuckles



## MAINTENANCE

### Bearing Maintenance

The Main Bearing on your Flycam Handheld Video Stabilizer is attached to the Central Post about two inches from the top. It is of metal construction and partially enclosed by the Bearing assembly.

If after a period of time your bearings don't turn smoothly, lubricate with a minimum of light machine oil. Light lubricating oil can also be used on the Yoke and Handle Bearings. Be sure to keep oil away from your camera, & clean up any over spill.

### Cleaning

Do not use solvents or harsh cleaners of any kind on your Flycam Handheld Video Stabilizer. If the unit becomes dirty, use a damp soft cloth or sponge and a mild detergent to gently clean external parts.

### Storage

- Should you need to store your Flycam Handheld Video Stabilizer for a long period of time then place the unit upright in a dry or low to normal humidity area whenever possible. If you are unable to find this kind of environment then we suggest you store the unit in an airtight plastic container or bag.
- Standing the unit upright is preferred as it alleviates stress on the system.

**Note:** *The Flycam Handheld Video Stabilizer doesn't work under water, nor is it waterproof. Avoid direct exposure to rain, water spray or any other harsh environment. Also the bearings are not sand/grit proof and need to be kept free of these contaminants. Avoid getting dirt or sand in them.*

## PRACTICE MAKES PERFECT - WALKING THE LINE

Practice this simple exercise to master your Flycam Handheld Video Stabilizer with professional results.

Using masking or gaffers tape, create a cross mark on a flat and even wall. The mark becomes your framing center. On the floor leading up to the cross mark, lay a straight tape line of about 20 feet. Practice walking the line, while keeping the cross mark center framed and in focus. With a bit of effort, dramatic fluid like movements will become second nature and provide production value to all your set ups.

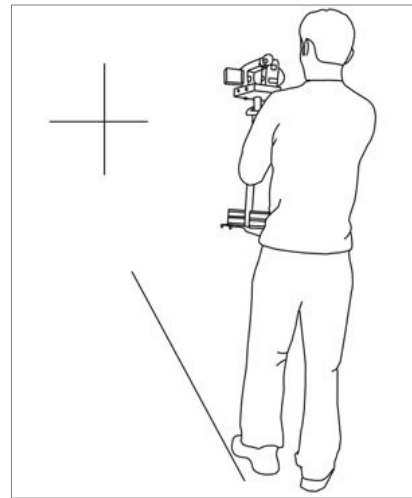

## WARRANTY

We offer a limited time warranty for our products. For Mechanical products we provide a 6 month warranty & for electronic products we provide a 3 month warranty from the date of purchase.

We will repair or replace your product, free of charge, in the event of a defect in materials or craftsmanship obtained during normal use or handling based on the user manual. Please note that we will not cover any shipping costs for returning the product to us. If any VAT or import duties are applied to the return, we will also charge these costs to the customer.

The warranty does not include, by the way of example, damage caused by products that we do not supply or from mishandling in transit, accident, misuse, neglect, lack of care of the product, or service by anyone other than our company.

We are not liable for incidental or consequential damages resulting from the use of the unit or occurring due to any breach of this warranty.

Replacement parts of the product will be provided at nominal cost (covering the cost price of the replacement parts only) to the customers after the Warranty Period has expired. We will cover the complete cost of sending replacement parts within the warranty period. After that, Nominal cost of the product & Actual shipping cost will be charged.

Do not send the unit to us without first getting a response and getting the approval to send back the item.

In case of any kind of dissatisfaction, we urge you to **Contact us** immediately and we shall do our best to help you out.

For any other assistance you can reach us via email.