

E8 ANC Wireless Headphones

User Guide

EN

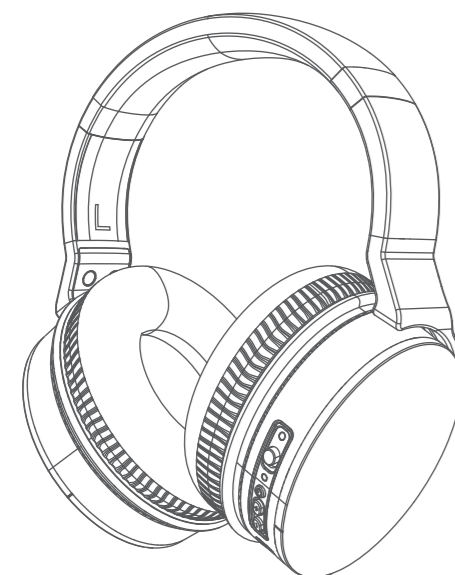

What's in the box

- E8 ANC Wireless Headphones
- Carrying Case
- USB Charging Cable
- 3.5mm Audio Cable
- User Guide
- Warranty Card

Overview

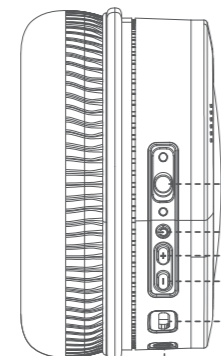

- Noise cancellation on/off switch
- Power / Bluetooth / Call control button
- Volume up / skip backward button
- Volume down / skip forward button
- USB charging port

Audio jack

Connections

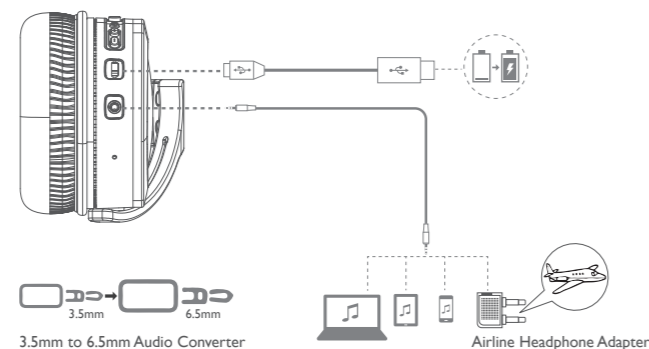

EN-1

LED Indicators

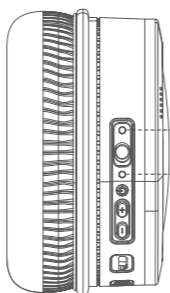

| Indicator Light Display | System status |
|-----------------------------------|----------------------------|
| Solid green | Noise cancellation ON |
| Flashing blue and red alternately | Power on & In pairing mode |
| Flashing red | Low Battery |
| Solid red | Charging in Process |
| Solid blue | Fully Charged |
| Flashing blue slowly | Paired |

Get Started

To power on: Press and hold for five seconds. You hear the power-on tones.

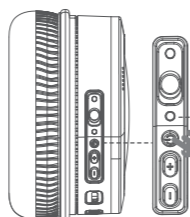

Tip: Once powered on, the white LED flashes blue and red alternately.

To power off: Press and hold for three seconds. You hear the power-off tones.

Use Your Headphones

Music Control

| Task | Button | Operation |
|--------------------------------|--------|------------------------------|
| Volume up / Skip backward | | Press once / Press and hold |
| Volume down / Skip forward | | Press once / Press and hold |
| Clear the headset pairing list | | Press and hold for 3 seconds |

EN-2

Call Control

| Task | Button | Operation |
|--------------------------|--------|-----------------------------|
| Pick up / hang up a call | | Press once |
| Reject an incoming call | | Press and hold for 1 second |

Bluetooth Connection

Note: The devices must be within range (32.8 ft. or 9 m) and powered on.

1. Turn on the headset. If connecting for the first time, the headphone will enter the pairing mode automatically after it is powered on.

Tip: Once powered on, the white LED flashes blue and red alternately.

2. On your mobile device, enable the Bluetooth feature.

Tip: The Bluetooth feature is usually found in the Setting menu.

3. Select your headphones from the device list.

Choose "E8" to connect

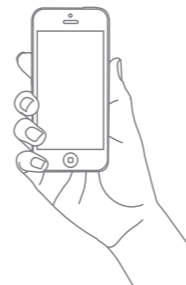
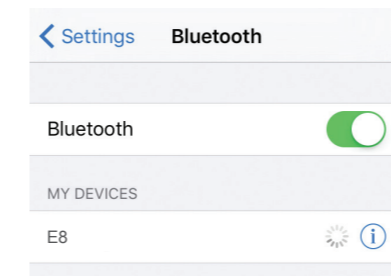

Tip: Once paired, you hear "Paired" and see the indicator flash blue slowly.

EN-3

Wear Your Headset

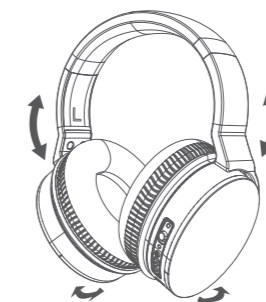

Adjust the headband to fit your head.

Detachable Earcups

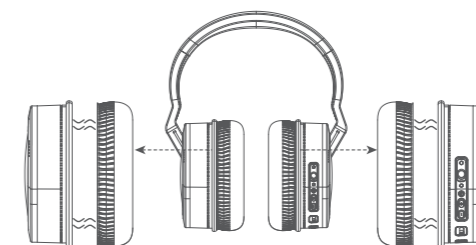

Detachable, magnetic earcups allow for easy replacement and cleaning.

Hearing Safety



Danger

- To avoid hearing damage, limit the time you use headphones at high volume and set the volume to a safe level. The louder the volume, the shorter the safe listening time is.

EN-4

CARE AND MAINTENANCE

- Do not drop, crush, bend or apply excessive force to the device.
- Do not expose your device to moisture, extreme or prolonged heat, cold, humidity, or other adverse conditions. Avoid storing it in damp, humid or wet places, as it is not waterproof.
- Clean the unit with a soft cloth or damp chamois leather. Never use solvents.
- The Unit can only be opened by qualified personnel.
- This device contains magnets. Keep magnetic field sensitive products such as credit cards and video screen away from this device to avoid damage.

FAQ

Q1: My Bluetooth headphones do not switch on.

- The battery level is low. Charge the headphones.

Q2: I have difficulty to pair my device to the headset.

- Make sure the headset is powered on.
- Make sure your device's Bluetooth feature is on.
- Make sure the headset is not paired by another device. If it is, turn the headset on and press '+' (volume up) and '-' (volume down) at the same time to clear the headset pairing list. Then, pair again.
- Move your device closer to the headphones and away from any interference or obstructions.

Q3: My Bluetooth headphones are connected to a Bluetooth enabled device, but music can not play on my headphones.

- Refer to the user manual of your device. Select to play through the headphones.
- Some of the music/video players may need you to go to the settings and select to play through the headphones from output device list.

Q4: The audio quality is poor and crackling noise can be heard.

- The Bluetooth device is out of range. Reduce the distance between your headphones and Bluetooth device, or remove obstacles between them.

EN-5