

CLASSIC BLENDER

Osterizer[®]
BLENDER

USER GUIDE
AND
RECIPES





IMPORTANT SAFEGUARDS

When you use electrical appliances, you should always follow basic safety rules. They include the following:

1. Read all instructions.
2. To avoid risk of shock, do not put motor base in water or other liquid.
3. Supervise children closely when they use or are nearby appliances.
4. Always use unit on a clean, flat, hard, dry surface. There should be no material such as a tablecloth or plastic between unit and surface.
5. Unplug appliance:
 - when not in use
 - before putting on or taking off parts
 - before cleaning
6. Don't touch moving parts.
7. Keep hands and utensils out of container while blending to reduce the risk of:
 - the possibility of severe personal injury
 - damage to the blender

If scraping is necessary, turn the unit OFF and use a rubber spatula only

6. Do not use appliance:
 - with a damaged cord or plug
 - after the unit fails to work correctly
 - after you drop or damage unit in any way

Return to nearest authorized Oster Service Center for safety check, adjustment or repair.

9. Blades are sharp. Handle them carefully

IMPORTANT SAFEGUARDS

10. To reduce the risk of injury:
 - don't leave agitator blades exposed
 - always assemble blades to container before putting on base
11. Always put cover on container before operating blender.
12. Never put *boiling* liquids in blender container.
13. When blending *hot* liquids, remove feeder cap from the two-piece cover to allow steam to escape.
14. Do not blend hot liquids in "Mini-Blend" jars.
15. Do not use outdoors.
16. Do not let cord:
 - hang over edge of table or counter
 - touch hot surfaces
17. Never leave appliance unattended while it is running.
16. You risk personal injury if you use attachments, containers, including canning or ordinary jars, or parts other than those recommended by Oster.

SAVE THESE INSTRUCTIONS

This unit is for household use only.

The maximum rating marked on the unit is based on the attachment that draws the greatest load. Other attachments may draw less power.

This appliance has a polarized plug (one blade is wider than the other). To reduce the risk of electric shock, this plug will fit in a polarized outlet only one way. If the plug does not fit fully in the outlet, reverse the plug. If it still does not fit, contact a qualified electrician. Do not modify the plug in any way. Refer to par. 40.35.

How to Use This Book

Congratulations! The Classic Osterizer® blender represents a tradition that we're proud to have bear our name. This "Classic" design is a symbol of excellence and quality. We're sure you'll enjoy its versatility and ease of use which will save you time and energy in food preparation.

Please pay special attention to the symbols on each page as they contain information you will find helpful. A complete nutritional analysis follows each of these recipes for your convenience.

About the nutritional analysis

If you're counting calories or just interested in healthful eating habits, review the nutritional analysis following each recipe.

When calculating recipes, the following guidelines were used:

- Meats were trimmed of excess fat and poultry was skinned when listed in recipe.
- The larger food quantity was calculated when a sliding scale was available. For example, 4-6 tablespoons; the greater amount was used.
- When a sliding scale was available for the number of servings, the smaller number was used.
- Optional ingredients and garnishes were not calculated.

Each analysts includes a serving size and nutritional information per each serving.

Nutritional analysis information was calculated using the Diet Simple PLUS™ computer software program.

Information on cholesterol content is provided for individuals who, on the advice of a physician, are modifying their total dietary intake of cholesterol.

The nutritional analyses given are approximations and calculated based on available reference data.

Light Fare Light Fare

A collection of recipes in the following section has been identified with the Light Fare symbol. These recipes were developed to be lower in fat, cholesterol and calories for more healthful dining.

Caution

This symbol has been placed in specific areas of the User Guide portion of this book. Its purpose is to easily identify instructions that require your special attention.

Our best to you

This book, as well as your new Classic Osterizer blender, comes to you with our best wishes. We hope that you enjoy using both for many years to come.

Your friends at Oster.

†Diet Simple PLUS is a trademark of N-Squared Computing.

The Osterizer® Blender

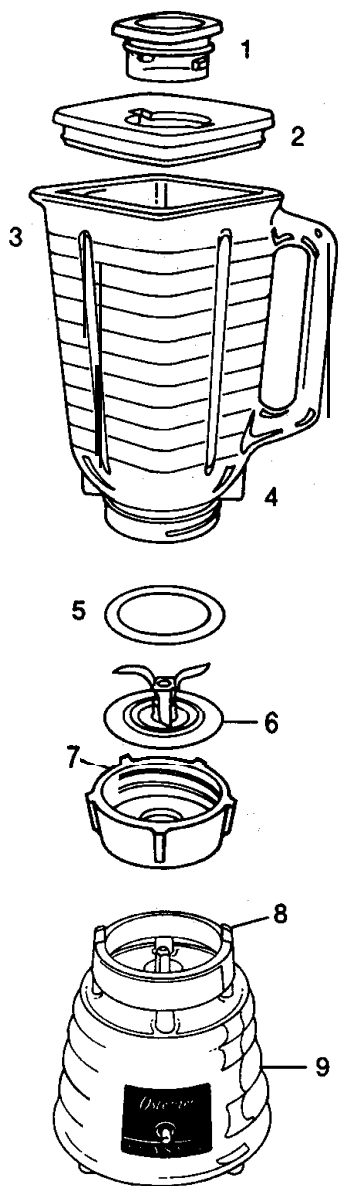

1. Feeder Cap doubles as measuring cup. Lets you add foods while blending.
2. cover.
3. **Blender Container** holds 5 cups (1.25L). Helps user estimate measures.
4. Lug contacts stop to prevent turning.
5. **Sealing Ring** seals jar and agitator blade assembly.
6. **Agitator Blades** create blending action.
7. **Container Bottom** holds container assembly together and positions container assembly on motor base.
6. **Stop** keeps container from turning in base.
9. **Motor Base** has a powerful two-speed motor that is the heart of the appliance. To maximize this unit's efficiency, only use the recommended processing amounts identified in the instruction manual and recipes.

How to Put Your Blender Together

Before you use the blender for the first time, separate the sealing ring, agitator blade and container bottom. Wash in warm, soapy water. Rinse. Dry well.

Assembly

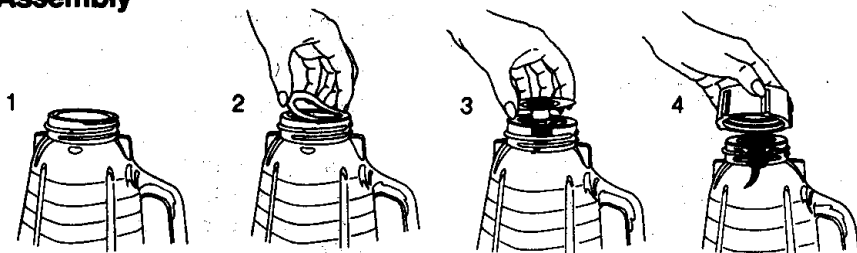

1. Turn container upside down.
2. Put sealing ring on opening.
3. Turn agitator blades upside down and place in container opening.
4. Screw container bottom firmly to container.

Tighten the bottom

If you have trouble tightening the container bottom by hand, follow steps 5-7. If not, go to step 8.

5. Unplug the appliance.
6. Put container into base ring with handle and lug as shown.
7. Turn container handle to the left to tighten bottom. Lift container from the base.

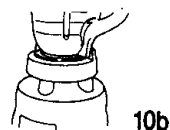
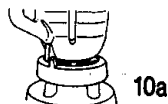
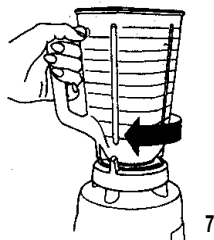
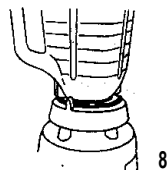

Seat the container

8. When you are ready to blend, put foods into the container in the amounts outlined in this book.
9. Make sure the cover is on securely.
10. Seat container in base ring as shown in 10a. If container does not seat firmly in that position, seat it as shown in 10b. Now the blender is ready to use.

Caring for Your Blender

Cleaning

▼ **Do not wash any blender parts except for glass blender container in an automatic dishwasher.**

1. Unplug unit.
2. Carefully remove the agitator blades, sealing ring and container bottom.
3. Wash in warm, soapy water.
4. Wash cover and container.
5. Rinse.
6. Dry well.
7. Wipe base with soft, damp cloth.

Storing

▼ **Never put blender container in microwave oven. Never store foods in your blender container.**

1. Put agitator blades, sealing ring and container bottom back together.

Upkeep

Check parts as you put them back together.

Blades

1. Turn as shown being careful of sharp blade edges.
2. Blades should turn freely.
3. If blades are stuck or hard to turn, do not use the **blender**.



Glass container

1. If your blender container is chipped or cracked, it could break during use.
Do not use blender.

Service

Only send your appliance to an authorized **Oster Service Center** if repairs are ever needed.

Use only replacement parts from **Oster**.

How to Use Your Blender

Osterizer



C L A S S I C

1. Plug in motor base.
2. Check recipe for recommended speed.
3. Rest hand on container cover.
4. Select proper speed.

▼ Never leave blender while it is operating. If container turns while motor is ON, immediately switch unit OFF and repeat steps 5-7 under "How to Put Your Blender Together."

The Osterizer blender, a P-speed unit

PULSE—this low speed setting is used for chopping and processing small quantities of medium or soft-textured foods to a smooth mixture.

To chop foods, push the switch down to the **PULSE** setting for 2 seconds (counting "1001.. .1002"). Release and let blades come to a stop. Repeat for the number of times given in the recipe. This technique can also be done in the **ON** setting for chopping harder-textured foods.

To process continuously for mixing light loads, hold the switch down in the **PULSE** position until the desired consistency is achieved.

ON—this high speed setting is used for chopping hard-textured foods and processing smooth mixtures.

In the **OFF** position, the appliance stops operating.

For additional food processing information, refer to chart on pages 10-13.

Scraping the container

1. Turn unit OFF
2. Use a rubber spatula to push foods away from the sides of the container.
3. Put cover on container.
4. To blend again, turn unit to PULSE or ON.
5. Follow blending steps.

Sepereting container from motor base

Never take container from base **during PULSE or ON.**

1. Unplug unit.
2. Lift container straight up.
3. If it does not lift out easily, rock gently then lift. Do not **twist**.

Removing foods

Never store foods in your blender container.

1. Take cover off.
2. Pour liquids/light batters from top of container.
3. Take thick mixtures out from the bottom of the container.

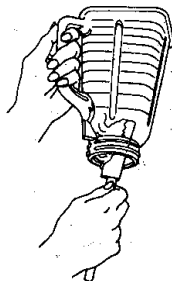

Removing container bottom

If you cannot unscrew the container bottom, put container back on the base, as shown.

1. Turn container to right using handle.
2. Only loosen part way
3. Carefully lift container from base.
(Bottom will be loose.)

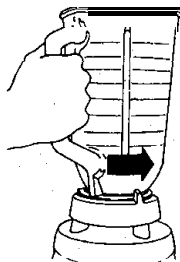

Use **this** guide to help you learn the processing techniques of your new **Classic Osterizer** blender

<i>SPEED</i>	<i>ACTION</i>	PROCEDURE
PULSE ON/OFF		
	Process 1 time	Hold switch down for a 2-second count.
	Process 2 times	Repeat as above waiting until agitator blades stop before processing again.
PULSE	CONTINUOUS RUN	Hold switch down until desired consistency is achieved.
ON ON/OFF		
	Process 1 time	Flip switch up for a P-second count and return switch to OFF .
	Process 2 times	Repeat as above.
ON	CONTINUOUS RUN	Flip switch up until food reaches desired smoothness and return switch to OFF .

Water chop (ON/OFF action)

Cover 2-4 cups (500mL-1L) fruits or vegetables, cut in 1-inch (2.5cm) pieces, with cold water. Cover. Process at **PULSE** until food reaches desired texture. If needed, drain water from food using a strainer.

Dry chop (ON/OFF action)

Place up to 1 cup (250mL) of food, cut in 1-inch (2.5cm) pieces, into container. Cover and process at **PULSE** until pieces are desired size.

Crumb (ON/OFF or CONTINUOUS RUN action)

Tear a **slice** of bread into 8 pieces. Put in container. Cover and process at **PULSE** or **ON** depending on desired texture.

Create cookie crumbs using the same process. Simply break cookies into container. Cover and process. (See page 10 for **more** information.)

Grind (CONTINUOUS RUN action)

Place up to 1 cup (250mL) of grain, nuts, spices or coffee beans in glass blender container. Cover. Process at **ON** until food reaches the "grind" you desire.

Grate (CONTINUOUS RUN action)

Cover container. Turn unit **ON**. With blender running, remove feeder cap. Drop up to 1 cup (250mL) of 1-inch (2.5cm) cubes of hard cheese, boneless cooked meat or coconut meat into container. Turn unit **OFF**. Check and repeat if needed.

Liquefy (CONTINUOUS RUN action)

Place 1-inch (2.5cm) pieces of fruit or vegetables in container with up to 1 cup (250mL) water. Cover. Turn unit **ON** until you can no longer see pieces of food. If you want chilled juice, remove feeder cap and add 3-4 ice cubes one at a time. Process at **ON** until cubes are dissolved. You may strain the fibers from the **juice** if you wish. To do so, use a fine strainer.

Reconstitute (CONTINUOUS RUN action)

Put water for frozen juice concentrate or condensed soup into container. Add frozen concentrate or soup. Cover. Process at **PULSE** just until well mixed. The **same** technique may be used **with** dry milk

Here are some helpful tips from the Oster experts, developed especially for you.

Liquids

Put liquids called for in recipes into the container first, unless the recipe says otherwise.

Ice cubes

Add ice cubes only when you have at least 1 cup (250mL) of liquid in the container. Add one at a time through feeder Cap while motor is running. Always use highest speed.

Removing cover

Don't remove the cover while blending. Food may spatter if you do. Instead, open the feeder cap to add foods.

Hot foods

Open the feeder cap when you're working with hot foods to vent steam. Tilt feeder cap away from you. Keep hands and other exposed skin away from the cover opening to prevent possible burns.

When you work with hot liquids, remove feeder cap and start blending at a low speed. Then move to faster speed. Do not add liquid over the 4-cup (1L) level.

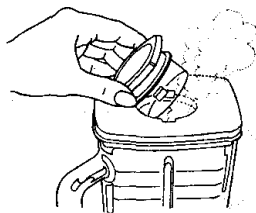

Food quantity

Blend only the amount of food suggested in this book. If you want greater amounts, blend in batches. Using larger amounts may overload and wear the motor. You might also get different results from those described.

Motor labors

Increase speed if motor labors while blending. This prevents motor wear.

Overblending

Don't overblend. The blender works in seconds, not minutes. Stop and check food before blending again.

Curdled mayonnaise

Empty blender container. Then process another egg and ¼ cup (50mL) of the curdled mayonnaise at ON. Take off feeder cap and pour rest of the mayonnaise into container. Blend until thickened. Turn unit OFF. Use a rubber spatula to scrape sides of blender container if needed.

Gravy or sauce lumps

Pour gravy or sauce into a measuring cup. Then put ½ cup (125mL) back into the blender container. Cover. Turn unit ON and remove feeder cap. Gradually, add the rest of the gravy or sauce. Blend until smooth.

Giblet gravy

Cook the giblets in water or broth. Cool to room temperature. Cut giblets in 1-inch (2.5cm) pieces. Put in blender container. Cover with cooled cooking liquid. Cover container. Process 2 times at PULSE. (If giblet pieces are still too large, process one or two additional times.)

Making butter

Pour 1 cup (250mL) sweet or sour heavy cream into blender container. Cover and process at ON until butter forms. Turn unit OFF. Pour through a sieve to drain. Put butter into small bowl. Press with a spatula to take out rest of liquid. Add salt as you knead the butter. If you want herb butter, add 1 tablespoon (15mL) dried herbs (parsley, tarragon, savory or a garlic clove) per cup (250mL) of cream.



FOODS FOR PROCESSING

FDDD	FINISHED QUANTITY	RAW, QUANTITY	SPECIAL INSTRUCTIONS
Apples	2 cups (500mL)	3 cups (750mL)	1-inch (2.5cm) pieces
	3/4 cup (200mL)	1 cup (250mL)	1-inch (2.5cm) pieces
Applejuice	1½ cups (375mL)	1 medium plus 1 cup (250mL) liquid"	peeled; cored, cut in eighths
Bread -coarse	½ cup (125mL)	1 slice	torn in eighths
-regular	½ cup (125mL)	1 slice	torn in eighths
-fine	½ cup (125mL)	1 slice	torn in eighths
Cabbages -red andwhite	1½ cups (375mL)	3 cups (750mL)	1-inch (2.5cm) pieces'
Carrots	2 cups (500mL)	2 cups (500mL)	1-inch (2.5cm) pieces
	1 cup (250ml)	1 cup (250 m	
Celery	¾ cup (200mL)	1 cup (250mL)	1-inch (2.5cm) pieces
Cheese -Cheddar	1 cup (250mL)	1 cup (250mL)	1-inch (2.5cm) pieces
-SWISS	1 cup (250mL)	1 cup (250mL)	1-inch (2.5cm) pieces
-hard/ semi-hard (cold)	1 CUP (250mL)	1 cup (250mL)	1-inch (2.5cm) pieces
Cranberries (fresh)	¾ cup (200mL)	1 cup (250mL)	
coconut	1 cup (250mL)	1 cup (250mL)	1-inch (2.5m) pieces
Coffeebeans	1 cup (250mL)	1 cup (250mL)	
Cookies -chocolate wafers	½ cup (125mL)	10	break into pieces
-vanilla wafers	½ cup (125mL)	16	break into pieces
-coconut (small)	½ cup (125mL)	8	break into pieces
1¼ cups (300mL) Corn kernels - dried	1¼ cups (300mL) cornmeal	1 cup (250mL)	
Crackers -soda	16	break into pieces	
-graham	8	break into pieces	

Note: Since foods vary in size, consistency, and age, you may need to add or subtract a processing time from the number stated in this chart to obtain the results you desire.

WATER CHOP	DRY CHOP	CRUMB	GRIND	GRATE	LIQUEFY	PROCESS AT	SPEED
X						2 times	LOW
	X					2 times	LOW
					X	CONTINUOUS	HIGH
		X				1 time	LOW
		X				4 times	LOW
		X				CONTINUOUS	HIGH
X						1 time	LOW
X						4 times	LOW
	X					2 times	LOW
	X					2-3 times	LOW
	X					2 times	HIGH
	X					5 times	LOW
				X		CONTINUOUS	HIGH
	X					2 times	LOW
				X		CONTINUOUS	HIGH
			X			45 sec. - Perc. 90 sec. - Drip	HIGH
		X				3 times	LOW
		X				3-4 times	LOW
		X				3-4 times	LOW
	X					1 minute	HIGH
		X				2 times	LOW
		X				3 times	LOW

FOODS FOR PROCESSING

FOOD	FINISHED QUANTITY	RAW QUANTITY	SPECIAL INSTRUCTIONS
Dried fruit	scant 1/2 cup (125ml)	1/2 cup (125mL)	process with 1/2 cup (125mL) flour
	2 cups (500mL)	2 cups (500ML)	process with 3 cups (750mL) water
Eggs -hard-cooked	3/4 cup (200ML)	2	1-inch (2.5cm) pieces
Green peppers	1 1/2 cups (375mL)	3 cups (750mL)	1-inch (2.5cm) pieces
	2/3 cup (150mL)	1 cup (250ML)	1-inch (2.5cm) pieces
Meal, boneless, cooked	1 cup (250ml)	1 cup (250mL)	1-inch (2.5m) pieces
Nuts -almonds	1 cup (250mL)	1 cup (250mL)	
-peanuts	1 cup (250mL)	1 cup (250mL)	
-pecans	1 cup (250mL)	1 cup (250mL)	
-walnuts	1 cup (250mL)	1 cup (250mL)	
Oats (meal)	1 1/3 cups (325mL)	1 cup (250mL)	
Onions	1 1/2 cups (375mL)	3 cups (750mL)	1-inch (2.5cm) pieces
Orange or lemon pad	1/4 cup (50mL)	peel of 1 lemon: or orange 1/2 cup (125mL)	freeie in thin strips first
Peppercorns	1/2 cup (125mL)	1/2 cup (125mL)	
Poppyseed	1 1/4 cups (300mL)	1 cup (250mL)	Turn OFF and scrape
Potatoes	2 cups (500ML)	3 cups (750mL)	1-inch (2.5cm) pieces
Rice, raw	1 cup (250mL) flour	1 cup (250nL)	
Whole spices -Ginger root	1/4 cup (50mL)	2-3 pieces	1-inch (2.5cm) pieces
-nutmeg	1 T. (15mL)	3	break with nutcracker
Wheatberries	1 1/4 cups (300ml.)	1 cup (250mL)	
Zwieback	1/2 cup (125mL)	, 6	break into container

Note: Since foods vary in size, consistency, and age, you may need to add or subtract a processing time from the number stated in this chart to obtain the results you desire.

WATER CHOP	DRY CHOP	CRUMB	GRIND	GRATE	LIQUEFY	PROCESS _____ AT	SPEED
	X					15 seconds	HIGH
X						30 seconds	HIGH
	X					2 times	LOW
X						1-2 times	LOW
	X					1 time	LOW
				X		CONTINUOUS	HIGH
	X					4 times	LOW
	X					3 times	LOW
	X					2 times	LOW
	X					2 times	LOW
			X			CONTINUOUS	HIGH
X						1 time	LOW
			X			CONTINUOUS	HIGH
			X			CONTINUOUS	HIGH
			X			CONTINUOUS	HIGH
X						3-2 seconds	HIGH
			X			CONTINUOUS	HIGH
			X			CONTINUOUS	HIGH
			X			CONTINUOUS	HIGH
		X				4 times	LOW

Salsa Light Fare

1 can (16 ounces or 454g)
whole tomatoes, drained
4 1-inch (2.5cm) pieces
green pepper
2 1-inch (2.5cm) pieces
onion

½-1 marinated or fresh jalapeño
pepper, seeded
½ teaspoon (1mL) cider vinegar
¼ teaspoon (1mL) cumin
4-8 drops hot pepper sauce

Place all ingredients into Osterizer blender container. Cover and process 2 times at PULSE until vegetables are chopped. Serve with corn chips.

Yield: approximately 1 cup (250mL)

NUTRITIONAL INFORMATION PER SERVING

Serving size . . . 1 tablespoon	Fat 0.1g	Sodium 375mg
Calories 5	Cholesterol 0mg	Protein 0.2g

Guacamole

2 large, ripe avocados,
peeled and cubed
½ medium tomato, cubed
1 tablespoon (15mL)
lemon juice

2 1-inch (2.5cm) pieces onion
¼ teaspoon (1mL) salt

Place all ingredients except ½ of 1 avocado into Osterizer blender container. Cover and process at ON until smooth. (If necessary, **stop blender**, use rubber spatula to keep mixture around the agitator blades. Cover and continue to process.) Remove cover and add remaining avocado. Cover and process 2-3 times at PULSE until desired consistency. Serve with corn chips, crackers or raw vegetables.

Yield: 1½ cups (375mL)

NUTRITIONAL INFORMATION PER SERVING

Serving size . . . 1 tablespoon	Fat 2.5g	Sodium 24.4mg
Calories 27	Cholesterol 0mg	Protein 0.3g

Mock Sour Cream Light Fare

Use as a substitute for sour cream in dressings or dips.

1 tablespoon (15mL) milk
1 tablespoon (15mL)
lemon juice

1 cup (250mL) low-fat
cottage cheese

Put all ingredients into Osterizer blender container. Cover and process at ON until smooth.

Yield: 1 cup (250mL)

NUTRITIONAL INFORMATION PER SERVING

Serving size . . . 1 tablespoon	Fat 0.2g	Sodium 58mg
Calories 11	Cholesterol 0.8mg	Protein 1.8g

Fruit Dip

½ cup (125mL) lemon yogurt
 1 tablespoon (15mL) honey
 ½ teaspoon (2mL) grated
 lemon rind

¼ teaspoon (1mL) lime juice
 4 ounces (227g) Neufchâtel
 Cheese, cut in 1-inch (2.5cm)
 pieces

Put yogurt, honey, lemon, and lime juice into Osterizer blender container. Cover and process at ON until lemon rind is finely grated. With motor running, remove feeder cap and add cheese. Continue to process until smooth. Refrigerate several hours. Serve with fresh fruit. *yield: 1½ cups (375mL)*

Variations:

Substitute equal proportions of any variety yogurt; i.e., mixed berry or peach, for lemon yogurt.

NUTRITIONAL INFORMATION PER SERVING

Serving size .. 1 tablespoon	Fat	2.36	Sodium	41mg	
Calories	33	Cholesterol	7.6mg	Protein	1.2g

Classic Swiss Fondue

1 clove garlic
 1 cup (250mL) dry white wine
 1 cup (250mL) milk
 1 pound (454g) natural
 Swiss cheese, cut in
 1-inch (2.5cm) cubes

3 tablespoons (45mL)
 cornstarch
 3 tablespoons (45mL) kirsch
 dash white pepper
 dash nutmeg

Put all ingredients, including garlic, into Osterizer blender container. Cover and process at ON until smooth. Pour into a fondue pot and cook at Hi, stirring constantly until mixture is heated and bubbly. Reduce heat to Yed-Lo to serve. *Serves 4-6 as main course 10-12 as appetizer*

NUTRITIONAL INFORMATION PER SERVING

Serving size 1 serving	Fat	33.6mg	Sodium	333mg
Calories 582	Cholesterol	114mg	Protein	34.7g

Non-Alcoholic Beverages

Tomato Juice Cocktail Light Fare

2 cups (500mL) tomato juice
 1 thin slice lemon with peel
 2 sprigs parsley
 ½-inch strip (1cm) green pepper
 8-inch stalk (20cm) celery,
 cut in 1-inch (2.5cm) pieces

½-inch slice (1cm) cucumber,
 unpeeled
 ¼ teaspoon (1mL) Worcestershire
 sauce
 salt to taste
 6 ice cubes

Put all ingredients into Osterizer blender container. Cover and process at ON until all ingredients are liquefied. *yield: approximately 3½ cups (875mL)*

NUTRITIONAL INFORMATION PER SERVING

Serving size	1 cup	Fat..	0g	Sodium	518mg*
Calories	28	Cholesterol	0mg	Protein	1.3g

*Sodium content may be greatly reduced by substituting low sodium tomato juice.

Vanilla Milk Shake

2 cups (500mL) vanilla
 ice cream, softened
 ½ cup (125mL) milk

½ teaspoon (2mL) vanilla
 extract

Put all ingredients into Osterizer blender container. Cover and process at ON until smooth. (If necessary, stop blender, use rubber spatula to keep mixture around the agitator blades.) *Yield: 2 cups (500mL)*

NUTRITIONAL INFORMATION PER SERVING

Serving size	1 cup	Fat	16.3g	Sodium	146mg
Calories	310	Cholesterol	67.3mg	Protein	6.8g

Variation:

Chocolate Milk Shake

Reduce milk to ¼ cup (50mL) and add ¼ cup (50mL) chocolate syrup. Omit vanilla extract. Process as above.

Strawberry Cooler

¼ cup (50mL) lemonade
 concentrate, thawed,
 undiluted
 ¾ cup (200mL) water

2 cups (500mL) strawberries
 2 tablespoons (30mL) sugar
 1 cup (250mL) ice cubes

Put all ingredients into Osterizer blender container. Cover and process at ON until slushy. *Yield: 3 cups (750mL)*

NUTRITIONAL INFORMATION PER SERVING

Serving size	1 cup	Fat	0.4g	Sodium	1.8mg
Calories	9	Cholesterol	0mg	Protein	0.6g

Non-Alcoholic Beverages

Fruit Smoothies Light Fare

- | | |
|--|----------------------------------|
| ½ cup (125mL) milk | 2 tablespoons (30mL) sugar |
| ½ cup (125mL) apple juice | ½ teaspoon (2mL) vanilla extract |
| 2 cups (500mL) fruit (strawberries, bananas or peaches) cut in 1-inch (2.5cm) pieces | 1 cup (250mL) ice cubes |

Put all ingredients except ice into Osterizer Mender container. Cover and process at ON until smooth. With motor running, remove feeder cap and add ice cubes. Continue to process until smooth. *Yield: 3 cups (750mL)*

NUTRITIONAL INFORMATION PER SERVING

Serving size	1 cup	Fat.,	1.8g	Sodium	22.6mg
Calories	.107	Cholesterol	5.5mg	Protein	2g

Mexican Chocolate

- | | |
|--|----------------------------------|
| ½ cup (125mL) semi-sweet chocolate morsels | ½ teaspoon (2mL) vanilla extract |
| 1 tablespoon (15mL) instant coffee powder | ¼ teaspoon (1mL) cinnamon |
| | 2 cups (500mL) hot milk |

Put all ingredients into Osterizer blender container. Cover blender and vent feeder cap. Process at PULSE until morsels are dissolved. Serve hot.

Yield: approximately 2½ cups (625mL)

NUTRITIONAL INFORMATION PER SERVING

serving size	5 ounces	Fat.	11.7g	Sodium	60.6mg
Calories	185	Cholesterol	16.5mg	Protein	4.9g

Alcoholic Beverages

Important: The blender container should contain at least 1 cup (250mL) of liquid in order for whole ice cubes to process properly. Some of the recipes in this section do not call for this much liquid. In these recipes only, follow this simple step: add all ingredients, cover container, and process 3 times at PULSE to break cubes. Then process for a few seconds.

Recipe Guidelines: 1½ ounces (45mL) = 1 jigger
1 ounce (30mL) = 1 pony

Daiquiri

½ cup (125mL) water
3 ounces (90mL) light rum

1 can (6 ounces or 177mL)
frozen limeade concentrate
1% cups (375mL) ice cubes

Put all ingredients except ice into Osterizer blender container. Cover and process at ON. With motor running, remove feeder cap and add ice cubes. Continue to process until smooth.

yield: 2 cups (500mL)

NUTRITIONAL INFORMATION PER SERVING

Serving size	1 cup	Fat	0g	Sodium	0.8mg
Calories	256	Cholesterol	0mg	Protein	0g

Variation:

Frozen Daiquiri

Omit water and add an additional 1½ cups (375mL) ice cubes.

Blue Margarita

½ cup (125mL) water
3 ounces (90mL) gold
tequila

1% ounces (45mL) blue
Curacao

1 can (6 ounces or 177mL)
frozen limeade concentrate
1% cups (375mL) ice cubes

Put all ingredients except ice into Osterizer blender container. Cover and process at ON. With motor running, remove feeder cap and add ice cubes. Continue to process until smooth. Serve over ice in a salt-rimmed glass.

Yield: 3 cups (750mL)

NUTRITIONAL INFORMATION PER SERVING

Serving size	1 cup	Fat	0g	Sodium	0.5mg
Calories	209	Cholesterol	0mg	Protein	0g

Variations:

Frozen Margarita

Omit water and add an additional 1½ cups (375mL) ice cubes. Process until slushy

Tradiil Margarita

Substitute an equal amount of Triple Sec for the blue Curacao.

Alcoholic Beverages

Frosty Sour

½ cup (125mL) water
 4 ounces (125mL) bourbon
 1 can (6 ounces or 177mL)
 frozen lemonade
 c o n -

1 can (6 ounces or 177mL)
 frozen orange juice
 concentrate
 1 cup (250mL) ice cubes

Put all ingredients except ice into Osterizer blender container. Cover and process at ON until smooth. With motor running, remove feeder cap and add ice cubes. Continue to process until smooth. Garnish with an orange slice and a maraschino cherry.
Yield: 3 cups (750mL)

NUTRITIONAL INFORMATION PER SERVING

Serving size	1 cup	Fat	0.0g	Sodium	2.9mg
Calories	286	Cholesterol	0mg	Protein	1.4g

Piña Colada

1 cup (250mL) cream of
 coconut
 ¾ cup (200mL) unsweetened
 pineapple juice
 4 ounces (125mL) light rum

1 tablespoon (15mL) milk
 1 can (8 ounces or 227g)
 juice-packed pineapple
 2 cups (500mL) ice cubes

Put all ingredients except ice into Osterizer blender container. Cover and process at ON. With motor running, remove feeder cap and add ice cubes. Continue to process until smooth. Garnish with a pineapple slice.
Yield: 4 cups (1 liter)

NUTRITIONAL INFORMATION PER SERVING

Serving size	1 cup	Fat	10.2g	Sodium	23.3mg
Calories	370	Cholesterol	0.5mg	Protein	0.5g

Watermelon Ice

¼ cup (50mL) orange juice
 2 ounces (60mL) strawberry
 liqueur

1½ ounces (45mL) vodka
 1 cup (250mL) ice cubes

Put all ingredients except ice into Osterizer blender container. Cover and process at ON. With motor running, remove feeder cap and add ice cubes. Continue to process until smooth.
Yield: 1 cup (250mL)

NUTRITIONAL INFORMATION PER SERVING

Serving size	1 cup	Fat	<0.1g	Sodium	2.5mg
Calories	3	Cholesterol	0mg	Protein	0.49

Brandy Alexander

½ cup (125mL) milk
1½ ounces (45mL) brandy
1% ounces (45mL) creme
 de cacao

1 quart (1 ltr)
 vanilla ice cream,
 softened slightly

Put all ingredients into Osterizer blender container. Cover and process at ON until smooth. *Yield: 3 cups (750mL)*

NUTRITIONAL INFORMATION PER SERVING

Serving size	1 cup	Fat	20.4g	Sodium	175 mg
Calories	464	Cholesterol	84.2mg	Protein	7.7g

Variations: Substitute the following liqueurs for the brandy and creme de cacao:

Grasshopper: 1½ ounces (45mL) white creme de cacao
 1½ ounces (45mL) green creme de menthe

Golden Cadillac: 1 ounce (30mL) Galliano
 2 ounces (60mL) white creme de cacao

Pink Squirrel: 1½ ounces (45mL) creme de noyaux
 1½ ounces (45mL) white creme de cacao

Koala Bear: 1½ ounces (45mL) white creme de cacao
 1½ ounces (45mL) coffee-flavored liqueur

Orange Blossom

3 ounces (90mL) gin
1 tablespoon (15mL)
 lemon juice

1 cup (250mL) orange sherbet,
 softened slightly
1 cup (250mL) ice cubes

Put all ingredients into Osterizer blender container. Cover and process at ON until of sherbet-like consistency. Spoon into cocktail glasses and serve with short straws. *Yield: 1% cups (400mL)*

NUTRITIONAL INFORMATION PER SERVING

Serving size	½ cup	F a t	0.8g	Sodium	18.2mg
Calories	93	Cholesterol	2.8mg	Protein	0.4g

Egg Nog

1½ ounces (45mL) light rum
¾ cup (150mL) half and half
3 eggs

2 tablespoons (30mL) sugar
4 ice cubes
 nutmeg

Put all ingredients except ice into Osterizer blender container. Cover and process at ON. With motor running, remove feeder cap and add ice cubes. Continue to process until smooth. Garnish with nutmeg. *Yield: 3 cups (750mL)*

NUTRITIONAL INFORMATION PER SERVING

Serving size	4 ounces	F a t	5.6g	Sodium	42.4mg
Calories	104	Cholesterol	116 mg	P r o t e i n	3.9g

Feeding baby need no longer mean separate cooking or purchasing of special foods. Family foods are fresher-and the blender gives them a uniform texture and smooth consistency.

Prepare regular family meals, then simply process baby's portion in the blender. Saves work, time and money-makes it easier to introduce new foods, too.

Always consult your physician before introducing new foods. Use these basic recipes as a guide- then prepare your own combinations from the family's meal.

Basic Recipes

Meats and Vegetables

½ cup (125mL) cubed, cooked
meat or vegetable

4-6 tablespoons (60-90mL)
milk, formula or other liquid

NUTRITIONAL INFORMATION PER SERVING*

Serving size	1 serving	Fat	13.6g	Sodium	80.9mg
Calories	242	Cholesterol	80mg	Protein	24.1g

*Nutritional analysis calculated using roast beef and milk.

Canned or Fresh Fruits

¾ cup (200mL) cooked fruit

2 teaspoons (10mL) fruit
juice or water

NUTRITIONAL INFORMATION PER SERVING*

Serving size	1 serving	Fat	0.2g	Sodium	12mg
Calories	143	Cholesterol	0mg	Protein	0.99

*Nutritional analysis calculated using peaches and water.

Put ingredients into Osterizer blender container. Cover and process at ON until smooth. To test for smoothness, rub a small amount between your fingers. If any large particles can be felt, process again. (Add full amount of liquid for very young babies-decrease amount as child grows older.)

Meat Combo Dish

½ cup (125mL) cubed, cooked lamb, beef, veal or chicken
2 tablespoons (30mL) cooked vegetables (carrots, peas, spinach, celery, squash)

1 strip crisp bacon
½ cup (125mL) milk
¼ cup (50mL) cooked rice

Put all ingredients into Osterizer blender container. Cover and process at ON until thoroughly pureed. Heat before serving. *Yield: 2- 3 servings*

NUTRITIONAL INFORMATION PER SERVING*

Serving size	1 serving	Fat	9g	Sodium	121mg
Calories	184	Cholesterol	44.7mg	Protein	14.3g

*Nutritional analysis calculated using roast beef and carrots.

Variation:

Chicken stew

In above recipe, substitute ¼ cup (50mL) chicken broth and ¼ cup (50mL) milk for the ½ cup (125mL) milk and continue with directions.

Note: For younger babies, add an extra ¼ cup (50mL) milk.

Fruity Cottage Cheese

¼ cup (50mL) orange juice or apple juice
½ cup (75mL) cottage cheese

½ cup (75mL) fresh fruit

Put all ingredients into Osterizer blender container. Cover and process at ON until smooth. *yield: 1 cup (250mL)*

NUTRITIONAL INFORMATION PER SERVING

Serving size	½ cup	Fat	1.7g	Sodium	152mg
Calories	65	Cholesterol	5.6mg	Protein	5.1g

*Nutritional analysis calculated using orange juice and peaches.

Carrot Bread

1½ cups (375mL) all-purpose flour
 1½ teaspoons (7mL) baking soda
 1½ teaspoons (7mL) cinnamon
 ½ teaspoon (2mL) salt
 1 cup (250mL) pecans

2 eggs
 1 cup (250mL) vegetable oil
 ¾ cup (200mL) sugar
 1 teaspoon (5mL) vanilla extract
 1% cups (375mL) carrot pieces, cut in 1-inch (2.5cm) pieces

Preheat oven to 350°F (180%). Grease a 9 x 5 x3-inch (23 x 13 x 8cm) loaf pan. Sift flour, baking soda, cinnamon and salt into large mixer bowl. Set aside. Blender-chop nuts. Add to dry ingredients. Put eggs, oil, sugar and vanilla extract into Osterizer blender container. Cover and process at ON until smooth. Stop blender, add carrot pieces, cover and process at ON until carrots are finely chopped. Pour over dry ingredients and mix only until dry ingredients are moistened. Pour into prepared pan and bake 1 hour or until toothpick comes out clean. Cool 5 minutes in pan, then turn out on cake rack and cool completely *Yield: 1 loaf*

NUTRITIONAL INFORMATION PER SERVING

Serving size 1/8 loaf	Fat	16.9g	Sodium	139mg	
Calories	229	Cholesterol	23.7mg	Protein	2.4g

Cranberry Nut Bread

1¼ cups (300mL) all-purpose flour
 ¾ cup (200mL) whole wheat flour
 1% teaspoons (7mL) baking powder
 ½ teaspoon (2mL) baking soda
 2 egg whites

¾ cup (200mL) orange juice
 ¼ cup (50mL) vegetable oil
 thin outer rind of ½ orange
 ¾ cup (200mL) sugar
 1 cup (250mL) cranberries
 ½ cup (125mL) nuts

Preheat oven to 350°F (180°C). Grease a 9 x 5 x3-inch (23 x 13 x 8cm) loaf pan. In a large mixer bowl combine flours, baking powder, baking soda and set aside. Put egg whites, orange juice, oil, rind, and sugar into Osterizer blender container. Cover and process at ON until rind is finely grated. Stop blender, add cranberries and nuts. Cover and process 2 times at PULSE. Pour over dry ingredients and mix only until dry ingredients are moistened. Pour into prepared pan and bake 50-55 minutes or until toothpick comes out clean. *Weld: 1 loaf*

NUTRITIONAL INFORMATION PER SERVING

Serving size 1/8 loaf	Fat	5g	Sodium	56.9mg	
Calories	134	Cholesterol	0mg	Protein	2.8g

Zucchini Bread

- | | |
|----------------------------------|---|
| 1 cup (250mL) all-purpose flour | 2 cups (500mL) zucchini, cut in 1-inch (2.5cm) pieces |
| 1 cup (250mL) whole wheat flour | 2 egg whites |
| 1 teaspoon (5mL) baking soda | ½ cup (125mL) water |
| 1 teaspoon (5mL) ground cinnamon | ½ cup (75mL) vegetable oil |
| ¾ teaspoon (3mL) ground cloves | ¾ cup (200mL) sugar |
| ¼ teaspoon (1mL) baking powder | 1 teaspoon (5mL) vanilla extract |
| ¼ teaspoon (1mL) salt | ½ cup (125mL) walnuts |

Preheat oven to 350°F (180%). Grease a 9 x 5 x 3-inch (23 x 13 x 8cm) loaf pan. In a large mixer bowl combine first seven ingredients and set aside. Put zucchini pieces into Osterizer blender container. Cover with cold water. Cover container and process 2 times at PULSE. Drain immediately through colander. Put egg whites, water, oil, sugar, vanilla, and nuts into blender container. Cover and process 2 times at PULSE. Pour over dry ingredients and zucchini and mix only until dry ingredients are moistened. Pour into prepared pan and bake 50-60 minutes or until toothpick comes out clean. *Yield: 1 loaf*

NUTRITIONAL INFORMATION PER SERVING

Serving size	¼ loaf	Fat	69	Sodium	87.2mg
Calories	139	Cholesterol	0mg	Protein	2.9g

Prepared Mixes

Follow recipe on box for ingredients. Assemble Osterizer blender. Put all ingredients into blender container, cover and process at PULSE until pancake mix is moistened. Pour out of container onto hot greased griddle about ¼ cup (50mL) at a time, and cook until brown.

Sour Milk Pancakes

- | | |
|---------------------------------------|--|
| 1 cup (250mL) sour milk or buttermilk | 1 teaspoon (5mL) baking soda |
| 1 egg | ½ teaspoon (2mL) salt |
| 1 tablespoon (15mL) sugar | 1 tablespoon (15mL) melted shortening or vegetable oil |
| 1 cup (250mL) all-purpose flour | |

Put all ingredients into Osterizer blender container. Cover and process at PULSE until well blended. Cook on a hot greased griddle until nicely browned. Turn only once.

Yield: 8-10 pancakes

NUTRITIONAL INFORMATION PER SERVING

Serving size 1 pancake	Fat	2.8g	Sodium	276mg
Calories 99	Cholesterol	27.8mg	Protein	3.4g

Low-Cholesterol Oatmeal Pancakes Light Fare

- | | |
|------------------------------------|-----------------------------------|
| 1½ cups (375mL) oatmeal | 2 tablespoons (30mL) brown sugar |
| ¾ cup (200mL) skim milk | 1 tablespoon (15mL) baking powder |
| 2 egg whites | ¼ teaspoon (1mL) salt, (optional) |
| 2 tablespoons (30mL) vegetable oil | cat flour (from above) |

To make oat flour, put oatmeal into Osterizer blender container. Cover and process at ON until the consistency of all-purpose flour. Remove from container. Put all ingredients into blender container in order listed. Cover and process at PULSE until smooth. Allow to stand for 5 minutes before using. Pour onto preheated, lightly greased griddle. Cook over medium-high heat until browned, turning once.

Yield: 8 4-inch (10cm) pancakes

NUTRITIONAL INFORMATION PER SERVING

Serving size 1-4-inch pancake	Calories 8	2	Cholesterol	0mg
	Fat	4.4g	Sodium	150mg
			Protein	2.5g

Potato Pancakes

- | | |
|--|-----------------------------------|
| 2 eggs | ¼ teaspoon (1mL) baking powder |
| 1 small onion | 3 cups (750mL) cubed raw potatoes |
| ½ teaspoon (2mL) salt | |
| 2 tablespoons (30mL) all-purpose flour | |

Put eggs, onion, salt, flour, baking powder and ½ cup (125mL) potato cubes into Osterizer blender container. Cover and process at ON until smooth. Add remaining potatoes, cover and process 3 times at PULSE. Pour onto a hot, well greased griddle. Drain on absorbent paper.

Yield: 12 pancakes

NUTRITIONAL INFORMATION PER SERVING

Serving size 1 pancake	Fat	0.9g	Sodium	109mg
Calories 48	Cholesterol	35.5mg	Protein	2g

Ad Lib Soup

$\frac{1}{2}$ cup (125mL) cooked
vegetables
1 tablespoon (15mL) soft butter

1 tablespoon (15mL) flour
 $\frac{1}{4}$ teaspoon (1mL) salt
1 cup (250mL) milk

Put all ingredients into Osterizer blender container. Cover and process at ON until smooth. Pour into small saucepan and heat over medium heat until hot.

Yield: 1 serving

NUTRITIONAL INFORMATION PER SERVING

Serving size ...	1 serving	Fat	19.7g	Sodium	774mg
Calories	291	Cholesterol	63.7mg	Protein	10.2g

Cream of Broccoli Soup

1 cup (250mL) water
1 package (10 ounces or 280g)
frozen chopped broccoli
2 cups (500mL) milk
2 cups (500mL) processed
cheese, cubed

2 chicken bouillon cubes
 $\frac{1}{2}$ cup (125mL) all-purpose flour
1 cup (250mL) half and half
croutons for garnish

In large saucepan, cook broccoli in 1 cup (250mL) water. (Do not drain.) Put milk, cheese cubes, bouillon and flour into Osterizer blender container. Cover and process at ON. Add cheese mixture to broccoli. Add the half and half. Cook, stirring frequently, over medium heat until hot and until mixture thickens. Serve garnished with croutons.

Yield: 4 - 6 servings

NUTRITIONAL INFORMATION PER SERVING

Serving size	1 serving	Fat	28g	Sodium	1337mg
Calories	451	Cholesterol	80.7mg	Protein	23g

Cream of Tomato Soup

- | | |
|---|----------------------------------|
| 1 cup (250mL) milk | 1 tablespoon (15mL) sugar |
| 2% cups (625mL) tomatoes | 1 thin slice onion |
| 2 tablespoons (30mL) all-purpose flour | 1 teaspoon (5mL) salt |
| 2 tablespoons (30mL) butter, softened | dash pepper |
| | dash garlic salt |

Heat milk in a small saucepan. Put remaining ingredients into Osterizer blender container. Cover and process at PULSE until smooth. increase speed to ON, remove feeder cap and slowly pour the hot milk into the mixture while processing. Reheat over low heat and serve immediately. *Weld: 4 servings*

NUTRITIONAL INFORMATION PER SERVING

Serving size	1 serving	Fat	8g	Sodium	630mg
Calories	135	Cholesterol	23.6mg	Protein	3.5g

Gazpacho Light Fare

- | | |
|---|--|
| 1 can (10% ounces or 305g) tomato juice* | ¼ small cucumber , cut in 1-inch (2.5cm) cubes |
| ¼ cup (50mL) beef broth | ½ teaspoon (2mL) salt |
| 2 medium tomatoes , cut in 1-inch (2.5cm) cubes | ½ teaspoon (2mL) garlic powder |
| 1 small onion , quartered | chopped parsley |
| ½ medium green pepper , seeded, cut in 1-inch (2.5cm) cubes | herb croutons |

Put first eight ingredients into Osterizer blender container. Cover and process 2 times at PULSE or until vegetables are coarsely chopped. Chill well. Serve with freshly chopped parsley and crisp herb croutons. *Yield: 3½ cups (875mL)*

Note: A 16-ounce (454g) can of whole tomatoes may be used instead of fresh tomatoes and tomato juice.

NUTRITIONAL INFORMATION PER SEWING

Sewing size	1 cup	Fat	0.4g	Sodium	376mg*
Calories	41	Cholesterol	<0.1mg	Protein	1.9g

*Sodium content may be greatly reduced by substituting low sodium tomato juice.

Strawberry Apple Gelatin Salad

Create a double layer taste treat

$\frac{1}{4}$ cup (50mL) cold water

1 envelope unflavored gelatin

1 package (3 ounces or 84g) strawberry-flavored gelatin

$\frac{3}{4}$ cup (200mL) boiling water

2 apples pared, cored and cut in eighths

1 package (10 ounces or 283g) frozen, sweetened strawberries, thawed slightly

Place cold water and unflavored gelatin into Osterizer blender container. Let stand for 2 minutes. Add strawberry gelatin and hot water. Cover and vent feeder cap. Process at PULSE for 1 minute or until gelatin is dissolved. Increase speed to ON, remove feeder cap and add apple pieces. Replace feeder cap and stop blender. Add strawberries and process 2 times at PULSE. Pour into a 1-quart (1 liter) mold. Chill until firm, about 3 hours or overnight. *Yield: 6 servings*

NUTRITIONAL INFORMATION PER SERVING

Serving size 1 serving	F a t	0.2g	Sodium	2.2mg
Calories 77	Cholesterol	0mg	Protein	1.6g

Salad of Gold

1 package (3 ounces or 84g) lemon-flavored gelatin

$\frac{3}{8}$ cup (175mL) boiling water

1 can (8 ounces or 227g) crushed pineapple in juice

1 tablespoon (15mL) cider vinegar

$\frac{3}{8}$ cup (175mL) evaporated milk

2 packages (3 ounces or 84g each) cream cheese, cubed

1 cup (250mL) carrot pieces

Put gelatin and hot water into Osterizer blender container. Cover and vent feeder cap. Process at PULSE until dissolved. Drain pineapple, reserving juice. Add enough water to juice to equal $\frac{3}{8}$ cup (175mL). Add juice, vinegar and milk to blender container. Process at ON, remove feeder cap and add cream cheese. When mixture is smooth, stop blender, remove cover and add carrot pieces and pineapple. Replace cover and process 4 times at PULSE. Pour into a 1½-quart (1.5 liter) ring mold and chill until set. *Yield: 6-8 servings*

NUTRITIONAL INFORMATION PER SERVING

Serving size 1 serving	Fat,	12.2g	Sodium	123mg
Calories	Cholesterol	40mg	Protein	4.7g

Blender, Coleslaw

Put 3 cups (750mL) of cabbage pieces into Osterizer blender container. Cover with cold water. Cover container and process 1 time at PULSE. (If a finer chop is desired, pulse again.) Drain immediately through colander and season. Mix with mayonnaise or any desired dressing. *yield: 1 ½ cups (375mL)*

NUTRITIONAL INFORMATION PER SERVING

Serving size $\frac{1}{2}$ cup	F a t	29.2g	Sodium	169mg
Calories 280	Cholesterol	0mg	Protein	1.8g

*Nutritional analysis calculated using $\frac{1}{2}$ cup (125mL) low-cholesterol mayonnaise found on page 29.

celery seed Dressing

½ cup (125mL) vegetable oil
 ½ cup (75mL) honey
 ¼ cup (50mL) white vinegar

1 teaspoon (5mL) salt
 ½ teaspoon (2mL) celery seed

Put all ingredients into Osterizer blender container. Cover and process at ON until well blended. *yield: approximately 1¼ cups (300mL)*

NUTRITIONAL INFORMATION PER SERVING

Serving size 1 tablespoon	Fat	5.5g	Sodium	107mg
Calories 66	Cholesterol	0mg	Protein	<0.1g

Mayonnaise

1 egg
 ½ teaspoon (2mL) salt
 ½ teaspoon (2mL) dry mustard
 ½ teaspoon (2mL) sugar

dash cayenne pepper
 2 tablespoons (30mL) white tarragon vinegar
 1 cup (250mL) vegetable oil

Put egg, seasonings, vinegar and ¼ cup (50mL) of oil into Osterizer blender container. Cover and process at ON. Immediately remove feeder cap and pour in the remaining oil in a steady stream. (If necessary, stop **blender**, use rubber spatula to keep mixture around agitator blades. Cover and continue to process.) Store covered in the refrigerator up to 1 week.

yield: approximately 1¼ cups (300mL)

Variation:

Low-cholesterol Mayonnaise



Use 2 egg whites instead of 1 whole egg. Proceed as above.

NUTRITIONAL INFORMATION PER SERVING

Serving size 1 tablespoon	Fat..	10.9g	Sodium	58.8mg
Calories 99	Cholesterol	0mg	Protein	.. 0.4g

Snappy French Dressing

1 cup (250mL) vegetable oil
 ⅓ cup (150mL) ketchup
 ½ cup (125mL) cider vinegar
 ½ cup (125mL) sugar
 ½ small onion, halved
 1 tablespoon (15mL) lemon juice

1 teaspoon (5mL) salt
 1 teaspoon (5mL) dry mustard
 1 teaspoon (5mL) paprika
 ¼ teaspoon (1mL) garlic powder
 dash pepper

Put all ingredients into Osterizer blender container. Cover and process at ON until blended. *Weld: 2% cups (625mL)*

NUTRITIONAL INFORMATION PER SERVING

Serving size 1 tablespoon	Fat	5.5g	Sodium	95.1mg
Calories 62	Cholesterol	0mg	Protein	<0.1g

Low-Calorie Ranch Dressing



1 cup (250mL) buttermilk
 1 cup (250mL) lowfat cottage cheese
 1 1-inch (2.5cm) piece onion
 ½ clove garlic

2 sprigs fresh parsley
 2 peppercorns
 ½ teaspoon (2mL) dill weed
 1 packet artificial sweetener

Put all ingredients into Osterizer blender container. Cover and process at ON until smooth. Chill for 1 hour before serving.

Yield: 2 cups (500mL)

NUTRITIONAL INFORMATION PER SERVING

Serving size .. 1 tablespoon	Fat	0.1g	Sodium	36.9mg	
Calories	9	Cholesterol	0.6mg	Protein	1.1g

Raspberry Vinaigrette

¼ cup (50mL) water
 ¼ cup (50mL) raspberry vinegar
 1 clove garlic
 ½-inch (1.25cm) slice shallot
 2 tablespoons (30mL) walnuts

1 teaspoon (5mL) Dijon mustard
 ½ teaspoon (2mL) sugar
 ¼ teaspoon (1mL) basil
 dash pepper
 dash salt
 ½ cup (125mL) safflower oil

Put first four ingredients into Osterizer blender container. Cover and process at ON until garlic and shallot are finely chopped. Stop blender and add all remaining ingredients except oil. Cover and process at ON. With motor running, remove feeder cap and pour in oil in a steady stream and process until well blended.

yield: 1 cup (250mL)

NUTRITIONAL INFORMATION PER SERVING

Serving size .. 1 tablespoon	Fat	8.1g	Sodium	62.4mg	
Calories	77	Cholesterol	0mg	Protein	0.3g

Italian Dressing

- | | |
|--|------------------------------|
| ¼ cup (50mL) white vinegar | 1 teaspoon (5mL) sugar |
| 1 clove garlic | 1 teaspoon (5mL) celery salt |
| 1 cup (250mL) vegetable oil | ½ teaspoon (2mL) dry mustard |
| 1 tablespoon (15mL) grated Parmesan cheese | ¼ teaspoon (1mL) pepper |
| 1 teaspoon (5mL) salt | 1-2 sprigs fresh parsley |

Put vinegar and garlic into Osterizer blender container. Cover and process at ON until garlic is finely chopped. Remove feeder cap and pour in all remaining ingredients except parsley and process until well blended. Stop blender. Add parsley. Cover and process 2 times at PULSE. *Weld: 1⅓ cups (325mL)*

NUTRITIONAL INFORMATION PER SERVING

Serving size	1 tablespoon	Fat	10.59	Sodium	107mg
Calories	95	Cholesterol	0.2mg	Protein	0.2g

Ginger Dressing

- | | |
|--|----------------------------|
| 3 tablespoons (45mL) white vinegar | 1 teaspoon (5mL) soy sauce |
| 1 clove garlic | ¼ teaspoon (1mL) pepper |
| ½-inch (1.25cm) piece fresh gingerroot | dash salt |
| ¼ cup (50mL) vegetable oil | 2 drops Sesame oil |

Put vinegar, garlic and gingerroot into Osterizer blender container. Cover and process at ON until garlic and gingerroot are finely chopped. Stop blender, add remaining ingredients, cover and process at PULSE until well blended. Serve over Chinese vegetables or with rice salad. *yield: ½ cup (125mL)*

NUTRITIONAL INFORMATION PER SERVING

Serving size	1 tablespoon	Fat	6.8g	Sodium	43.1mg
Calories	63	Cholesterol	0mg	Protein	0.1g

Green Goddess Slim Dressing

- | | |
|---|---------------------------|
| ½ cup (125mL) water | 1 teaspoon (5mL) tarragon |
| 1 cup (250mL) cottage cheese | ½ teaspoon (2mL) salt |
| 2 sprigs fresh parsley | ½ teaspoon (2mL) sugar |
| 1 teaspoon (5mL) chives, dried or fresh | 1 clove garlic |
| | cracked pepper |

Put all ingredients into Osterizer blender container. Cover and process at ON until smooth. Refrigerate for 15-30 minutes before serving to allow flavors to blend. *Yield: 1% cups (300mL)*

NUTRITIONAL INFORMATION PER SERVING

Serving size	1 tablespoon	Fat	0.1g	Sodium	99.3mg
Calories	9	Cholesterol	0.5mg	Protein	1.4g

Mexican Style Rice

3 cups (750mL) canned tomatoes
 1 medium onion, quartered
 1 green pepper, cut in 1-inch (2.5cm) pieces
 1 cup (250mL) Cheddar cheese cubes (1-inch or 2.5cm)

1 jar (4 ounces or 113g) pimientos, drained
 1 teaspoon (5mL) salt
 ¼ teaspoon (1mL) garlic salt
 ¼ teaspoon (1mL) oregano dash pepper
 2 cups (500mL) uncooked instant rice

Put all ingredients except rice into Osterizer Mender container. Cover and process 4 Cmes at PULSE. Mix with rice and pour into a greased P-quart (2 liter) casserole. Bake, covered, at 350°F (180°C) for 35-40 minutes. *Yield: 6-8 servings*

NUTRITIONAL INFORMATION PER SERVING

Serving size	1 sewing	Fat	6.7g	Sodium	759mg
Calories	178	Cholesterol	19.8mg	Protein	8.5g

Sole Elegante

2 cups (500mL) dry white wine
 1 small onion, quartered
 1 bay leaf
 ¼ teaspoon (1mL) black peppercorns
 ¼ teaspoon (1mL) salt

2 pounds (1kg) sole fillets
 2 eggs
 3 ounces (85g) cream cheese, softened and cut into 1-inch (2.5cm) pieces
 1 tablespoon (15mL) savory
 ½ teaspoon (2mL) salt

Put wine and onion into Osterizer blender container. Cover and process 2 times at PULSE. Place in a large skillet. Add bay leaf, peppercorns and ¼ teaspoon (1mL) salt. Cover and simmer 10 minutes. Wash and dry fillets. Select 8 fillets of approximately the same size. Cube remaining fillets. Squeeze out water with hands. Put all remaining ingredients and ½ of the fillet cubes into blender container. Cover and process at ON until smooth. (If necessary, stop blender, use rubber spatula to keep mixture around agitator blades.) Add remaining fillet cubes, cover and process at ON until smooth. With fillets skin side down, place ¼ cup (50mL) of mixture in center of fillet. Fold ends over mixture and secure with toothpick. Place into skillet; cover and cook over medium heat about 20 minutes or until fish flakes. Remove to platter. Serve with Bearnaise Sauce (page 36). *Yield: 6 servings*

NUTRITIONAL INFORMATION PER SERVING

Serving size	1 serving	Fat	9.1g	Sodium	492mg
Calories	336	Cholesterol	189mg	Protein	39.9g

*Nutritional analysis calculated for Sole Elegante only.

Chicken with Parmesan Cream Sauce

1 ounce (28g) Parmesan cheese, cut in 1-inch (2.5cm) cubes	dash onion salt
½ cup (150mL) heavy cream	2 chicken breasts, split and boned
1 egg yolk	½ cup (125mL) all-purpose flour
2 sprigs parsley	½ teaspoon (2mL) salt
¼ teaspoon (1mL) crushed tarragon	1 tablespoon (15mL) vegetable oil
¼ teaspoon (1mL) cracked pepper	1 tablespoon (15mL) butter

Blender-chop cheese. Add cream, yolk, parsley, tarragon, pepper and onion salt. Cover and process 3 times at PULSE. Pour into small saucepan and wok over medium heat until thickened, stirring occasionally. Meanwhile, remove skin from chicken pieces. Using a mallet or a rolling pin pound chicken to ½-inch (.3cm) thickness. Mix together flour and salt. Press both sides of each piece of chicken into flour to coat. Heat oil and butter over medium high heat in large frypan until lightly browned. Cook chicken in fat about 3 minutes on each side until no longer pink on inside. Add more butter and oil if needed. Remove to plate and pour sauce over chicken. *Weld: 4 servings*

NUTRITIONAL INFORMATION PER SERVING

Serving size	1 serving	Fat	28.6g	Sodium	513mg
Calories	458	Cholesterol	199mg	Protein	34.9g

chicken in Rice

1 cup (250mL) uncooked long grain rice	¼ teaspoon (1mL) salt
1 2½-3 pound (1.1-1.4kg) broiler-fryer chicken, cut into pieces	¼ teaspoon (1mL) ground pepper
½ cup (125mL) whole almonds	1 medium onion, quartered
1 cup (250mL) milk	1 stalk celery, cut into 1-inch (2.5cm) pieces
1 can (10¼ ounces or 305g) condensed cream of mushroom soup	4 sprigs parsley

Put rice into a 13 x 9 x Z-inch (33 x 23 x 5cm) baking pan. Arrange chicken pieces over the rice. Blender-chop nuts. Set aside. Put remaining ingredients into Osterizer blender container. Cover and process 2-3 times at PULSE or until vegetables are finely chopped. Pour over chicken. Sprinkle with chopped nuts. Cover tightly with foil. Bake in preheated 350°F (160°C) oven for 45 minutes. Remove foil, bake additional 15 minutes. *yield: 4 servings*

NUTRITIONAL INFORMATION PER SERVING

Serving size	1 serving	Fat	57.7g	Sodium	907mg
Calories	1085	Cholesterol	302mg	Protein	107g

Meat Loaf

2 slices bread
 1½ pounds (681g) ground beef
 ½ pound (227g) ground pork
 2 eggs
 1 medium onion, quartered
 6 sprigs parsley

1 teaspoon (5mL) Worcestershire sauce
 1 cup (250mL) canned, drained tomatoes
 1 teaspoon (5mL) salt
 ½ teaspoon (2mL) pepper

Heat oven to 350°F (180°C). Break 1 slice of bread in 8 pieces into Osterizer blender container. Cover and process 2 times at PULSE. Empty into mixing bowl. Repeat with remaining bread. Add meat. Put remaining ingredients into blender container. Cover and process 2 times at PULSE. Pour over meat and crumbs, mix thoroughly. Pack into a loaf pan and bake about 1 hour. *Yield: 8 servings*

NUTRITIONAL INFORMATION PER SERVING

Serving size	1 serving	Fat	.25.4g	Sodium	.435mg
Calories	.371	Cholesterol	152mg	Protein	28.6g

Quiche Lorraine

4 eggs
 1½ cups (375mL) cream or undiluted evaporated milk
 1 tablespoon (15mL) all-purpose flour
 ½ teaspoon (2mL) salt
 ¼ teaspoon (1mL) pepper
 ¼ teaspoon (1mL) ground nutmeg

1 medium onion, quartered
 1% cups (375mL) Swiss cheese, cubed
 1 pound (454g) pork sausage, fried and crumbled
 OR
 ¾ pound (339g) sliced bacon, crisply fried and crumbled
 1 9-inch (23cm) unbaked pie shell

Preheat oven to 375°F (190°C). Put eggs, light cream or evaporated milk, flour, salt, pepper and nutmeg into Osterizer blender container. Cover and process at PULSE until well blended. Stop blender and add onion pieces and Swiss cheese cubes. Cover and process 2-3 times at ON. Sprinkle crumbled sausage or bacon into bottom of unbaked pie shell and pour egg mixture into pie shell. Bake for 35-45 minutes or until a knife inserted into center comes out clean.

Yield: one 9-inch (23cm) Quiche

NUTRITIONAL INFORMATION PER SERVING

Serving size	¼ quiche	Fat	62.66	Sodium	1524mg
Calories	766	Cholesterol	301mg	Protein	32g

White Sauce

Thin:

1 tablespoon (15mL) butter and 1 tablespoon (15mL) all-purpose flour for each cup of milk or cream.

Medium:

2 tablespoons (30mL) butter and 2 tablespoons (30mL) all-purpose flour for each cup of milk or cream.

Thick:

3-4 tablespoons (45-60mL) butter and 3-4 tablespoons (45-60mL) all-purpose flour for each cup of milk or cream.

Put ingredients into Osterizer blender container. Cover and process at PULSE until well blended. Pour into saucepan and cook over low heat, stirring constantly until thick. Season to taste with salt and pepper.

Yield: approximately 1 cup (250mL)

NUTRITIONAL INFORMATION PER SERVING

Serving size	1 tablespoon	Fat	3.4g	Sodium	36.5mg
Calories	42	Cholesterol	9.7mg	Protein	0.7g

Cheese Sauce

Add 1 cup (250mL) cubed processed American cheese and 1/4 teaspoon (1mL) Worcestershire sauce to ingredients for White Sauce. Cover and process at ON until smooth.

NUTRITIONAL INFORMATION PER SERVING

Serving size	1 tablespoon	Fat	5.9g	Sodium	155mg
Calories	72	Cholesterol	17.6mg	Protein	2.9g

Hollandaise Sauce

4 egg yolks	dash of hot pepper sauce
1/4 teaspoon (1mL) dry mustard	1/2 cup (125mL) butter, melted
1 tablespoon (15mL) lemon juice	

Put egg yolks, mustard, lemon juice and hot pepper sauce into Osterizer blender container. Cover and process at ON. With motor running, remove feeder cap and pour butter in a slow, steady stream until mixture is completely emulsified. Keep warm over hot (not boiling) water.

Yield: 3/4 cup, (200mL)

NUTRITIONAL INFORMATION PER SERVING

Serving size	2 tablespoons	Fat	18.9g	Sodium	162mg
Calories	177	Cholesterol	184mg	Protein	2.1g

Bearnaise Sauce

2 tablespoons (30mL) dry white wine	2 peppercorns
2 tablespoons (30mL) tarragon vinegar	4 egg yolks
4 sprigs parsley	½ teaspoon (2mL) dry mustard
1 small onion, quartered	2 teaspoons (10mL) lemon juice
½ teaspoon (2mL) tarragon	dash hot pepper sauce
½ teaspoon (2mL) chervil	½ cup (125mL) butter, melted

Put wine, vinegar, parsley and onion into Osterizer blender container. Cover and process 2 times at PULSE. Put into small saucepan with tarragon, chervil and peppercorns. Bring to a boil; cook until liquid has completely evaporated. Put into blender container. Add egg yolks, dry mustard, lemon juice and hot pepper sauce. Cover and process at ON. With motor running, remove feeder cap; pour butter in a steady stream until mixture is emulsified. This may be kept warm in top of double boiler. Serve over meat or fish. *Yield: 1 cup (250mL)*

NUTRITIONAL INFORMATION PER SERVING

Serving size 2 tablespoons	Fat	14.2g	Sodium	122mg
Calories. 141	Cholesterol	138mg	Protein	1.7g

Fresh Applesauce

¼ cup (50mL) liquid (fruit juice or water)	¼ cup (50mL) sugar
4 apples, cut in eighths, peel if desired	dash cinnamon

Put liquid and 4 or 5 pieces of apple into Osterizer blender container. Cover and process at ON until smooth. With motor running, remove feeder cap and add remaining apples a few at a time. Add sugar and cinnamon. Blend until smooth. *yield: approximately 2 cups (500mL)*

Low-Calorie Apple Sauce



Omit sugar and use ¼ cup (50mL) low-calorie, lemon-lime soda for the liquid.

Note: Add 2 teaspoons (10mL) ascorbic acid powder to keep fruit from darkening.

NUTRITIONAL INFORMATION PER SERVING

Serving size ½ cup	Fat	.05g	Sodium	9.8mg
Calories 82	Cholesterol	0mg	Protein	0.3g

To Freeze:

Use ½ cup (125mL) corn syrup and ¼ cup (50mL) lemon juice in place of liquid and sugar. Pour into freezer container, allowing ¼-inch (1.25cm) headspace. Freeze.

Barbecue Sauce

- | | |
|--|---------------------------------------|
| ½ cup (125mL) ketchup | 1 tablespoon (15mL) lemon juice |
| 1 slice medium onion | ½ teaspoon (2mL) salt |
| 1 clove garlic | ½ teaspoon (2mL) dry mustard |
| 2 tablespoons (30mL) brown sugar | ½ teaspoon (2mL) prepared horseradish |
| 1 tablespoon (15mL) Worcestershire sauce | |

Put all ingredients into Osterizer blender container. Cover and process at ON until thoroughly blended. Use to baste chicken, beef or pork. *yield: ¾ cup (150mL)*

NUTRITIONAL INFORMATION PER SERVING

Serving size 2 tablespoons	F a t . . . O . l g	Sodium	.500mg
Calories .51	Cholesterol	Protein	0.2g

Tartar Sauce

- | | |
|--|------------------------------|
| ½ cup (125mL) mayonnaise | 1 teaspoon (5mL) lemon juice |
| 2 5-inch (8cm) baby dill pickles, cut in 1-inch (2.5cm) pieces | 1 1-inch (0.6cm) slice onion |
| | 3 sprigs parsley |

Combine all ingredients in Osterizer blender container. Cover and process at ON until onion and pickles are chopped. *Yield: ¾ cup (200mL)*

NUTRITIONAL INFORMATION PER SERVING

Serving size 2 tablespoons	F a t . . . 14.7g	Sodium	206mg
Calories .134	C h o l e s t e r o l 10.7mg	Protein	0.3g

Sweet-Sour Basting Sauce



- | | |
|--|--|
| 2 tablespoons (30mL) vegetable oil | ½ cup (75mL) brown sugar |
| 1 teaspoon (5mL) salt | ½ cup (125mL) wine vinegar |
| 3 1-inch (2.5cm) pieces green pepper | 1 teaspoon (5mL) soy sauce |
| 1 can (6 ounces or 168g) pineapple juice concentrate | ½ jar (2 ounces or 56g) pimiento |
| ½ dove garlic | pineapple chunks and green pepper strips |

Put all ingredients except pineapple chunks and green pepper strips into Osterizer blender container. Cover and process at ON until thoroughly blended. Brush on pork or chicken while it broils, roasts, or barbecues. Add a few pineapple chunks and green pepper strips for garnish. *yield: 2 cups (500mL)*

NUTRITIONAL INFORMATION PER SERVING

Serving size 2 tablespoons	Fat 1.7g	Sodium 156mg
Calories 40	Cholesterol 0mg	Protein 0.1g

Fresh Horseradish Light Fare

1 cup (250mL) horseradish
root, cut in ½-inch
(1.25cm) cubes

¼ cup (200mL) white vinegar
2 tablespoons (30mL) sugar
¼ teaspoon (1mL) salt

Put all ingredients into Osterizer blender container. Cover and process at ON until finely grated. *yield: approximately 1½ cups (375mL)*

NUTRITIONAL INFORMATION PER SERVING

Serving size	1 tablespoon	Fat	<0.1g	Sodium	24.5mg
Calories	6	Cholesterol	0mg	Protein	0.1g

Spaghetti Sauce

1 can (2 pounds or 908g)
tomatoes with juice
1 small onion, cut in eighths
½ green pepper, cut in
1-inch (2.5cm) pieces
2 tablespoons (30mL) vinegar
1 tablespoon (15 mL)
brown sugar

1 teaspoon (5mL) salt
1 teaspoon (5mL) oregano
¼ teaspoon (1mL) ground pepper
1 clove garlic
1 can (16 ounces or 454g)
tomato sauce
2 bay leaves

Put first nine ingredients into Osterizer blender container. Cover and process 2 times at PULSE. Pour into Dutch oven. Add tomato sauce and bay leaves. Heat to boiling and simmer for 1 hour. Serve with 1 pound (454g) cooked spaghetti and grated Parmesan cheese. *Yield: 5 cups (1.25L) or 5-6 servings*

NUTRITIONAL INFORMATION PER SERVING

Serving size	1 cup	Fat	0.7g	Sodium	1272mg
Calories	83	Cholesterol	0mg	Protein	3.2g

Vanilla Cream Pie

3 cups (750mL) milk
 ⅔ cup (150mL) sugar
 ¼ cup (50mL) cornstarch
 ¼ teaspoon (1mL) salt
 4 egg yolks, beaten

2 tablespoons (30mL) margarine
 2 teaspoons (10mL) vanilla extract
 1 9-inch (23cm) baked pastry shell

Put milk, sugar, cornstarch and salt into Osterizer blender container. Cover and process at PULSE until smooth. Pour into P-quart (2 liter) saucepan. Cook over medium-high heat, stirring constantly, until mixture thickens and boils. Boil 1 minute. Add half of mixture to egg yolks. Stir well. Add to remaining mixture. Cook and stir for 2 minutes. Remove from heat. Add margarine and vanilla. Pour into pastry shell. Chill. Top with whipped cream, if desired.

NUTRITIONAL INFORMATION PER SERVING

Serving size ⅓ pie	Fat 14.39	Sodium 311mg
Calories 283	Cholesterol 119mg	Protein 5.7g

Variations:

Banana Cream Pie

Slice 2 medium bananas. Place on bottom of pastry shell. Cool filling before pouring into shell.

Coconut Cream Pie

Stir 1 cup (250mL) coconut into filling before pouring into shell. Garnish with toasted coconut, if desired.

Yield: one 9-inch (23cm) pie

Tropical Cream Pie

Prepare this dessert the day before serving. Y's ready when you are.

1 can (20 ounces or 560g)
 pineapple chunks in natural
 juice, drained; reserve juice
 ⅓ cup (75mL) pineapple juice
 1 package (3 ounces or 84g)
 cream cheese, softened
 2 tablespoons (30mL) sugar
 1 cup (250mL) coconut

½ teaspoon (2mL)
 almond extract
 1 container (8 ounces or 227g)
 frozen nondairy whipped
 topping, thawed
 1 9-inch Graham-Nut Crust,
 baked and cooled (page 46)
 toasted coconut

Put pineapple juice, cream cheese, sugar, coconut and extract into Osterizer blender container. Cover and process at PULSE until well mixed. Add pineapple chunks. Cover and process 2 times at PULSE or until pineapple is crushed. Fold into whipped topping. Spoon into prepared crust. Freeze until firm, about 3-4 hours. Remove from freezer 15 minutes before serving. Garnish with toasted coconut if desired. Return leftovers to freezer.

Yield: one 9-inch (23cm) pie

NUTRITIONAL INFORMATION PER SERVING

Serving size ⅓ pie	Fat 259	Sodium 183mg
Calories 372	Cholesterol 27.2mg	Protein 2.9g

Cherry Cream Cheese Pie

2 eggs

1 package (8 ounces or 227g)
cream cheese, cut in cubes
and softened

¼ cup (50mL) sugar

1 9-inch (23cm) Graham
Cracker Crust

1 can (21 ounces or 595g)
cherry pie filling

Preheat oven to 325°F (160°C). Put eggs, cream cheese and sugar into Osterizer blender container. Cover and process at ON until smooth. Pour into prepared crust. Bake for 20 minutes. Remove from oven and spread cherry pie filling over top of pie. Chill. Garnish with whipped cream. *Yield: one 9-inch (23cm) pie*

NUTRITIONAL INFORMATION PER SERVING

Serving size	¼ pie	Fat	16.7g	Sodium	224mg
Calories	295	Cholesterol	85.3mg	Protein	4.69

Pumpkin Pie

½ cup (125mL) milk

½ cup (125mL) light cream

2 eggs

1½ cups (375mL) canned
pumpkin

¾ cup (175mL) brown sugar

1 teaspoon (5mL) cinnamon

½ teaspoon (2mL) salt

½ teaspoon (2mL) ground
ginger

¼ teaspoon (1mL) ground
cloves

Y 1 teaspoon (1mL) allspice

1 teaspoon (5mL) vanilla
extract

1 g-inch (23cm) unbaked
pastry shell

Preheat oven to 425°F (220°C). Put all ingredients into Osterizer blender container. Cover and process at ON until thoroughly blended. Pour into pastry shell and bake at 425°F (220°C) for 20 minutes, then reduce heat to 350°F (180°C) and bake 35-45 minutes longer, or until a knife inserted near center of pie comes out clean. Cool at room temperature before serving. *Yield: one 9-inch (23cm) pie*

NUTRITIONAL INFORMATION PER SERVING

Serving size	¼ pie	Fat	12.4g	Sodium	332mg
Calories	252	Cholesterol	71.9mg	Protein	4.2g

Espresso Mousse

¼ cup (50mL) cold water	1 tablespoon (15mL) sugar
2 envelopes unflavored gelatin	½ teaspoon (2mL) vanilla extract
½ cup (125mL) brewed espresso	1 cup (250mL) heavy cream
½ cup (125mL) boiling water	2 egg yolks
1 cup (250mL) semi-sweet chocolate morsels	½ cups (375mL) ice cubes

Put cold water and gelatin into Osterizer blender container and let set 2 minutes; then add hot espresso and boiling water. Cover, vent feeder cap and process at PULSE until gelatin is dissolved. Turn unit to ON. With motor running, remove feeder cap, add chocolate morsels, sugar and vanilla. Continue processing until mixture is smooth. Add cream, egg yolks and ice, replace cap and continue processing until mixture begins to thicken. Pour at once into serving dishes. Let set 5-10 minutes before serving. Garnish with sweetened whipped cream and chocolate shavings.

yield: 6-8 servings

NUTRITIONAL INFORMATION PER SERVING

Serving size 1 serving	Fat 26.6g	Sodium 21mg
Calories 318	Cholesterol 125mg	Protein 4.9g

Quick Gelatin Mold

1 package (3 ounces or 85g) fruit-flavored gelatin	½ cup (125mL) boiling water
	1½ cups (375mL) ice cubes

Put gelatin and boiling water into Osterizer blender container. Cover, vent feeder cap and process at PULSE until gelatin is dissolved. Turn unit to ON, remove feeder cap and add ice. Process until ice is liquefied and mixture begins to thicken. Pour into a 2-cup (500mL) mold; chill 5 minutes before unmolding. Or, pour into serving dishes and chill 5 minutes before serving.

yield: 4-6 servings

NUTRITIONAL INFORMATION PER SERVING

Serving size 1.serving	Fat	Og	Sodium	Omg
Calories .12	Cholesterol	Omg	Protein	0.4g

Quick Layer Cookies

16 graham cracker squares
 ½ cup (125mL) melted butter
 or margarine
 1 cup (250mL) walnuts
 1 package (6-ounce or 170g)
 semi-sweet chocolate bits

1 package (6-ounce or 170g)
 butterscotch bits
 ½ cups (325mL) flaked
 coconut
 1 can (14-ounce or 397g)
 sweetened condensed milk

Heat oven to 375°F (190°C). Break 8 graham cracker squares into Osterizer blender container. Cover and process 3 times at PULSE. Empty and repeat. Pour butter into a 13 x 9 x P-inch (33 x 23 x 5cm) pan; top with graham cracker crumbs, pressing evenly in bottom of pan. Place walnuts in blender container. Cover and process 2 times at PULSE. Sprinkle over crumbs. Layer in order listed, all remaining ingredients, pouring milk over entire mixture. Bake 25 minutes. Let cool and cut into squares. *yield: 4 dozen*

NUTRITIONAL INFORMATION PER SERVING

Serving size 1 square	Fat,	7.1g	Sodium	.52.7mg
Calories. 114	Cholesterol	2.8mg	Protein	1.7g

Bittersweet Brownies

1 cup (250mL) pecans
 ½ cup (125mL) flour
 1 teaspoon (5mL) baking
 powder
 ½ teaspoon (2mL) salt
 2 eggs

½ cup (125mL) soft butter
 1 cup (250mL) sugar
 1 teaspoon (5mL) vanilla
 extract
 2 squares unsweetened
 chocolate, melted

Preheat oven to 350°F (180°C). Grease a 9-inch (23cm) square pan. Put nuts into Osterizer blender container, process 2 times at PULSE and empty into mixing bowl. Sift flour, baking powder and salt into bowl with nuts and set aside. Put eggs, butter, sugar, vanilla and chocolate into blender container. Cover and process at ON until smooth. Pour over flour mixture and mix until well blended. Spread in prepared pan and bake 20-30 minutes. Cool. Cut into bars or squares.

Yield: approximately 24 squares

NUTRITIONAL INFORMATION PER SERVING

Serving size 1 square	Fat	8.6g	Sodium	103mg
Calories. 123	Cholesterol	28.1mg	Protein	1.4g

Blender Cheese Cake



1½ cups (400mL) graham cracker crumbs

½ cup (125mL) butter or margarine, melted

½ cup (125mL) boiling water

1 package (3 ounces or 84g) lemon-flavored gelatin

2 tablespoons (30mL) lemon juice

2 cups (500mL) cottage cheese

1 container (8 ounces or 227g) frozen whipped topping

Combine cracker crumbs and butter; mix well. Press into bottom of 7 x 11-inch (18 x 28cm) pan. Set aside. Pour boiling water into Osterizer blender container, add gelatin, cover, vent feeder cap and process at PULSE until gelatin is dissolved. Add lemon juice and 1 cup (250mL) cottage cheese. Cover and process at ON until smooth. Add remaining cottage cheese and process until smooth. Pour cheese mixture into large mixer bowl. Add frozen whipped topping. With rotary beater, mix until smooth. Pour over graham cracker crust. Chill until set. (This is ready for serving in minutes.)

Note: Flavor of gelatin may be varied. For an added treat, spread pie filling over cheese cake after it has set. Refrigerate 1 hour. Serve. If desired, 1 cup (250mL) fresh fruit can be folded into the mixture before pouring into crust.

yield: 10-12 servings

NUTRITIONAL INFORMATION PER SERVING

Serving size 1 serving	Fat.	18.2g	Sodium	382mg
Calories 278	Cholesterol	6.8mg	Protein	7.4g

Chocolate Glaze

- ½ cup (75mL) boiling water
- ¼ cup (50mL) butter, softened
- 2 squares unswweetened chocolate, cut in small pieces
- 2 cups (500mL) sifted powdered sugar

Put water, butter and chocolate into Osterizer Mender container. Cover, vent feeder cap and process at PULSE until smooth. Stop blender. add half the sugar, cover and process at ON until sugar is moistened. Stop and add remaining sugar, cover and process until smooth and creamy. *Yield: approximately 1 cup (250mL)*
Glazes *two 8 or 9-inch (20- 23cm) layers*

NUTRITIONAL INFORMATION PER SERVING

Serving size	1 recipe	Fat	.76.5g	Sodium	.474mg
Calories	1472	Cholesterol	124mg	Protein	6.6g

Butter Cream Glaze

- ¼ cup (50mL) butter or margarine, softened
- 3 tablespoons (45mL) milk
- ½ teaspoon (2mL) vanilla extract
- 1½ cups (375mL) powdered sugar

Put all ingredients into Osterizer blender container. Cover and process at ON until smooth and well blended. *Weld: ¾ cup (200mL)*
Glazes *one bundt cake*

NUTRITIONAL INFORMATION PER SERVING

Serving size	1 recipe	F a t	47.7g	Sodium	494mg
Calories	1021	Cholesterol..	131mg	Protein	2g

Creamy Frosting

- 1 tablespoon (15mL) light cream
- 1 teaspoon (5mL) vanilla extract
- 3 ounces (85g) cream cheese, softened
- 1 tablespoon (15mL) butter or margarine, softened
- ¼ teaspoon (1mL) salt
- 1½ cups (375mL) powdered sugar

Put all ingredients except powdered sugar into Osterizer blender container. Cover and process at ON until smooth. Add 1 cup (250mL) powdered sugar, cover and continue to process at ON until smooth. Add remaining sugar, continue to blend until smooth. *Yield: ¾ cup (200mL)*

Frosts one 9 x 9 x P-inch (23 x 23 x 5cm) cake

NUTRITIONAL INFORMATION PER SERVING

Serving size	1 recipe	F a t	46g	Sodium	910mg
Calories	1036	Cholesterol	141mg	Protein	6.9g

Bittersweet Chocolate Frosting

2 squares (1 ounce or 28g each)
unsweetened chocolate,
cut into small pieces
2 tablespoons (30mL) butter

¼ cup (50mL) hot milk
2 cups (500mL) powdered sugar
1 teaspoon (5mL) vanilla extract

Put all ingredients into Osterizer blender container. Cover, vent feeder cap and process at ON until completely smooth. If frosting is too thick, add a small amount of milk.

*Weld: approximately 1 cup (250mL)
Frosts one 13 x 9-inch (33 x 23cm) cake*

NUTRITIONAL INFORMATION PER SERVING

Serving size	1 recipe	Fat	55.2g	Sodium	266mg
Calories	1315	Cholesterol	69.7mg	Protein	8.3g

Chocolate Cookie Crust

30 chocolate wafer cookies
or 1½ cups (375mL) crumbs
¼ cup (50mL) butter, melted

½ teaspoon (2mL) cinnamon

Break 10 chocolate cookies into Osterizer blender container. Cover and process 3 times at WLSE. Empty container and repeat with remaining cookies. Combine cookies, butter, and cinnamon. Pat into a 9-inch (23cm) pie pan. Chill before filling or bake 10 minutes at 350°F (180%). Let cool before filling.

yield: one 9-inch (23cm) crust

NUTRITIONAL INFORMATION PER SERVING

Serving size	¼ crust	Fat	8.7g	Sodium	205mg
Calories	146	Cholesterol	17.7mg	Protein	1.5g

Buttery Nut Crust

½ cup (75mL) nuts
¾ cup (200mL) all-purpose flour
¼ cup (50mL) brown sugar

½ teaspoon (2mL) cinnamon
¼ cup (50mL) butter, melted

Preheat oven to 325°F (160°C). Put nuts into Osterizer blender container. Cover and process 2 times at PULSE. Put all ingredients into a 9-inch (23cm) pie pan. Mix thoroughly. Pat into bottom and sides of pie pan. Bake 20 minutes. Cool before filling.

Yield: one 9-inch (23cm) crust

NUTRITIONAL INFORMATION PER SERVING

Serving size	¼ crust	Fat	8.9g	Sodium	61.2mg
calories	152	Cholesterol	15.6mg	Protein	2.6g

crumb crust

1 package graham crackers,
22 squares, or
1 1/2 cups (375mL) crumbs
1/2 cup (75mL) butter, melted

2 tablespoons (30mL)
granulated sugar
1/2 teaspoon (2mL) cinnamon

Break 8 graham cracker squares into Osterizer blender container. Cover and process 3 times at PULSE. Empty container and repeat with remaining crackers. Combine crackers, butter, sugar, and cinnamon. Pat into bottom and sides of pie pan. Chill before filling or bake 10 minutes at 350°F (180°C). Let cool before filling.
yield: one 9-inch (23cm) crust

NUTRITIONAL INFORMATION PER SERVING

Serving size	1/2 crust	Fat	8.6g	Sodium	186mg
Calories	152	Cholesterol	19.5mg	Protein	1.5g

Variation:

Substitute cookie or zweiback crumbs for graham wakers.

Graham-Nut Crust

14 graham cracker squares
1/2 cup (125mL) pecans

2 tablespoons (30mL) sugar
1/4 cup (50mL) butter, melted

Preheat oven to 350°F (180°C). Break 8 graham cracker squares into Osterizer blender container. Cover and process 3 times at PULSE or until finely crumbed. Empty container and repeat with remaining crackers and nuts. Combine crackers, nuts, sugar, and butter. Pat into a 9-inch (23cm) pie pan. Bake 15 minutes. Cool.
yield: one 9-inch (23cm) crust

NUTRITIONAL INFORMATION PER SERVING

Serving size	1/2 crust	Fat	11.1g	Sodium	109mg
Calories	149	Cholesterol	15.6mg	Protein	1.3g

Peanut Butter

1½ cups (375mL) salted
cocktail peanuts

Put peanuts into Osterizer blender container. Cover and process at ON to the desired consistency. (If necessary, stop **blender**, use rubber scraper to keep mixture around the agitator blades.)

yield: ¾ cup (200mL)

NUTRITIONAL INFORMATION PEP **SERVING**

Serving size	2 tablespoons	Fat	17.8g	Sodium	157mg
Calories	210	Cholesterol	0mg	Protein	9.7g

Chicken Salad

1 small sweet pickle

½ cup (75mL) mayonnaise

1 1-inch (2.5cm) piece onion

½ teaspoon (2mL) sugar

1 chicken breast, deboned,
cooked, and cubed
(measure 1 cup or 250mL)

dash salt
dash pepper

Place pickle and onion into Osterizer blender container. Cover and process at PULSE until finely chopped. Stop blender, add chicken. Cover and process 3-4 times at PULSE. (If necessary, stop **blender**, use rubber scraper to keep mixture around agitator blades.) Empty into bowl, add remaining ingredients and mix thoroughly.

yield: 1 cup (250mL)

NUTRITIONAL INFORMATION PEP **SERVING**

Serving size	2 tablespoons	Fat	9.4g	Sodium	85.3mg
Calories	120	Cholesterol	26.1mg	Protein	7.7g

Egg Salad

6 hard-cooked eggs, quartered	$\frac{1}{4}$ teaspoon (1mL) salt
$\frac{1}{2}$ cup (75mL) mayonnaise	$\frac{1}{4}$ teaspoon (1mL) Worcestershire sauce
1 1-inch (2.5cm) piece onion	2 dashes hot pepper sauce
3 1-inch (2.5cm) pieces celery	dash pepper
1 teaspoon (5mL) prepared mustard	

Put 2 eggs into Osterizer blender container. Cover and process 1 time at PULSE. Empty into bowl and repeat with remaining eggs. Put remaining ingredients into blender container. Cover and process at PULSE until mixed. Add to eggs and mix thoroughly. *Yield: 1 $\frac{1}{2}$ cups (375mL)*

NUTRITIONAL INFORMATION PER SERVING

Serving size 2 tablespoons	Fat	11.1g	Sodium	176mg
Calories 124	Cholesterol	165mg	Protein	4.99g

Ham Salad

2 sweet pickles, cut in 1-inch (2.5cm) pieces	1 cup (250mL) cubed cooked ham
1 1-inch (2.5cm) piece onion	$\frac{1}{2}$ cup (75mL) mayonnaise

Place pickles and onion into Osterizer blender container. Cover and process at PULSE until finely chopped. Empty into small mixer bowl. Replace cover. Turn unit ON, remove feeder cap and add ham. Process until finely chopped. Add ham and mayonnaise to mixer bowl. Mix thoroughly. *Yield: 1 cup (250mL)*

NUTRITIONAL INFORMATION PER SERVING

Serving size 2 tablespoons	Fat	11.1g	Sodium	357mg
Calories 119	Cholesterol	14.8mg	Protein	3.4g

Tomato Juice



Cut out stems, white cores and any soft spots in tomatoes. Fill Osterizer blender container with quartered tomatoes. Cover and process at ON until smooth. Pour through strainer to remove seeds. Measure juice and pour into saucepan. Add 2 tablespoons (30mL) lemon juice and 1 teaspoon (5mL) salt for each quart (liter) of juice. Bring to boiling point and remove from heat. Remove foam. Fill hot, sterilized canning jars, leaving 1-inch (0.6cm) headspace; seal. Process in boiling water bath canner 40 minutes for pints (500mL), 45 minutes for quarts (liters).

Note: Approximately 2½–3 pounds (1.2–1.5 kg) tomatoes yield 1 quart (1 liter) juice.

NUTRITIONAL INFORMATION PER SERVING

Serving size 1 cup	Fat	0.7g	Sodium	161mg
Calories 67	Cholesterol	0mg	Protein	3g

Peach Jam

3 pounds (1.5kg) firm,
ripe peaches
7 cups (1.75 liters) sugar

¼ cup (50mL) lemon juice
1 bottle (6 ounces or 170g)
pectin

Wash, peel, pit and quarter peaches. Put 3 or 4 peach pieces into Osterizer blender container. Cover and process at PULSE. Empty into kettle. Repeat process with remaining peaches. Add sugar and lemon juice. Bring to rolling boil and boil hard for 10 minutes. Add pectin and boil for 1 minute. Remove from heat. Stir and skim for 5 minutes. Pour into sterilized canning jars and seal. **Process** 10 minutes in boiling water bath canner. *Weld: 8 M-pints (2 liters)*

NUTRITIONAL INFORMATION PER SERVING

Serving size 1 tablespoon	Fat	<0.1g	Sodium	0.5mg
Calories 44	Cholesterol	0mg	Protein	0.1g

Strawberry Freezer Jam

1 quart (1 ltr) strawberries
4½ cups (1.12 liters) sugar

3 ounces (85g) liquid pectin

Put 1 cup (250mL) strawberries into Osterizer blender container. Cover and process 1 time at PULSE. Remove to a large glass measuring cup. Repeat with remaining berries. Measure 2½ cups (625mL) strawberries; add water if needed. Pour into large mixer bowl. Add sugar. Mix well and allow to stand 20 minutes. Add pectin and stir constantly for 3 minutes. Pour into clean freezer containers or canning jars, leaving ½-inch (2.5cm) headspace. Cover and let stand at room temperature 24 hours. Freeze or store in refrigerator. If separation occurs, stir fruit and gelatin together until well mixed. *yield: 3 pints (1.5 liters)*

NUTRITIONAL INFORMATION PER SERVING

Serving size 1 tablespoon	Fat	<0.1g	Sodium	0.4mg
Calories 36	Cholesterol	0 mg	Protein	CO.19

Apple Butter

4 pounds (2kg) apples

1 cup (250mL) cider or
apple juice

2 cups (500mL) sugar

1 teaspoon (5mL) cinnamon

½ teaspoon (2mL) nutmeg

½ teaspoon (2mL) ground cloves

Wash and core apples; cut in eighths. Put ½ cup (75mL) cider and 5 or 6 pieces of apple into Osterizer blender container. Cover and process at ON until smooth. With motor running, remove feeder cap and add apple pieces until container is filled. Empty into saucepan. Repeat with remaining cider and apples. Add sugar and spices to pureed apples. Simmer about 45 minutes, stirring occasionally. Pour at once into sterilized jars, leaving ¼-inch (0.6cm) headspace; seal. Process 10 minutes in boiling water bath canner. If a smoother butter is desired, cook 30 minutes, then process in blender and cook an additional 15 minutes before canning.

Yield: approximately 3 pints (1.5 liters)

NUTRITIONAL INFORMATION PER SERVING

Serving size	1 tablespoon	F	a	t	O.1g	Sodium	0.3mg
Calories	28	Cholesterol			Omg	Protein	<0.1g

Variation:

Plums may be used in place of apples.

Raw Cranberry Relish

2 cups (500mL) cranberries

1 orange, cut in eighths

¾ cup (200mL) sugar

Put 1 cup (250mL) cranberries into Osterizer blender container. Cover and process 2 times at PULSE. If necessary, **stop** Mender, push berries from side of container and process 2 additional times at PULSE. Empty into bowl. Repeat with remaining berries. Put orange and sugar into blender container. Cover and process at ON until smooth. Add to berries and mix well. Let stand at least 30 minutes before serving.

yield: 2 cups (500mL)

NUTRITIONAL INFORMATION PER SERVING

Serving size	¼ cup	Fat	<0.1g	Sodium	0.2mg
Calories	89	Cholesterol	09	Protein	0.2g

These accessories and replacement **parts can be** purchased at retail outlets or at authorized Oster Service Centers. Only use the **accessory model** numbers listed Mow for this unit.

FOOD PROCESSOR ACCESSORY

Replace your food processor accessory or add another for busy days.
5900-06

"BLEND 'N STORE" PERMA-GLAS™ CONTAINERS

30-ounce (950mL) cold- and break-resistant Perma-Glas™ (plastic) container. Blend and then store reconstituted frozen orange juice, salad dressings or pancake batters.
927-91

STAINLESS STEEL BLENDER CONTAINER WITH COVER

5-cup (1.25L) rust- and stain-resistant container. Seamless. Marked for measuring. Molded fingertips.
927-09

S-CUP (1.25L) PERMA-GLAS™ BLENDER CONTAINER

Made of cold- and break-resistant plastic.
927-25

S-CUP (1.25L) GLASS BLENDER CONTAINER **927-35**

ICE CRUSHER ACCESSORY

Crush ice instantly for the buffet or bar. Continuous feed operation.
5940-08

MINI-BLEND@ JARS

Blend and store small portions with 1 cup (250mL) Perma-Glas™ jars made of cold- and break-resistant plastic. Set of 2 with covers.
927-13

SEALING RING (2 EACH) **939-58**

AGITATOR BLADE UNIT WITH SEALING RING **939-59**

CONTAINER BOTTOM **939-60**

NOTES/NOTAS

NOTES/NOTAS



Oster

U.S. PATENTS **4,462,694** AND **4,783,173**

© 1994 Sunbeam-Oster Company, Inc. or its
affiliated companies. All rights reserved.

PRINTED IN MEXICO.

® **OSTER, OSTERIZER, MINI-BLEND**
T.M. PERMA-GLAS

35936 REV. B