

## Replacement Parts List

**NOTE:** If requested color is not available, similar color will be substituted. Prices are subject to change.

**Part..... Cost..... Qty.....Total Cost**

Pad Set ..... \$13.99 ..... \$ \_\_\_\_\_

Instructions ..... \$0.00 ..... \$ \_\_\_\_\_

**Merchandise Total.....\$ \_\_\_\_\_**

**Shipping and handling:.....\$ \_\_\_\_\_**

Up to \$25.00.....\$5.95	\$150.01 to \$200.00..\$11.95
\$25.01 to \$50.00.....\$6.95	\$200.01 and up .....\$13.95
\$50.01 to \$75.00.....\$8.95	Outside Continental USA \$10.00
\$75.01 to \$100.00....\$9.95	
\$100.01 to \$150.00..\$10.95	

**Sales Tax .....\$ \_\_\_\_\_**

(Arizona, California, Georgia, Indiana, Missouri, South Carolina, and Texas residents add applicable sales tax.)

**Grand Total .....\$ \_\_\_\_\_**

No shipping and handling on instructions for quantities under 6. Add \$.50 for each instruction over 6, then add applicable shipping and handling.

### Fill Out For Credit Card

Visa     Mastercard

**Card Exp. Date:** \_\_\_\_\_

**Cardholder's Name:** \_\_\_\_\_

**Card Number:** \_\_\_\_\_

**Signature** \_\_\_\_\_

CUT ON DOTTED LINE

# Pronto Belt-Positioning Booster Instruction Manual

**40-100 lbs. (18.1-45.4 kg) 43-57" (110.1-144.8 cm)  
and at least 4 years old**

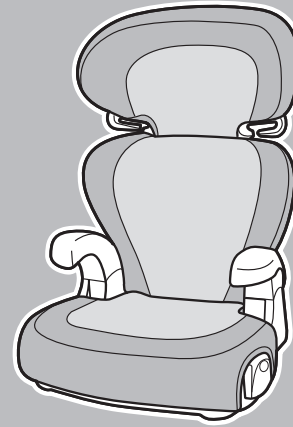

**KEEP INSTRUCTIONS FOR FUTURE USE.**

Read all instructions before using  
this child restraint.

**⚠ WARNING:**

**Failure to follow the warnings on the labels  
and in the instruction manual can result in  
serious injury or death to your child.**



**A. Before You Begin.....** Pages 3-6

- A-1 Thank You...
- A-2 Registration and Safety Notices
- A-3 Understanding Your Child Restraint

**B. Safety Information.....** Pages 7-8

- B-1 Vehicle Seating Position
- B-2 Installation in Vehicle
- B-3 Child Restraint Use

**C. Basic Use .....** Pages 9-18

- C-1 Preparing Child Restraint
- C-2 Adjusting Headrest
- C-3 Adjusting Backrest
- C-4 Removing Backrest
- C-5 Cup Holder
- C-6 Removing Seat Pad for Cleaning

**D. General Vehicle Installation ....** Pages 19-21

- D-1 Understanding Your Vehicle
- D-2 Vehicle Seating Position
- D-3 Knowing Your Vehicle Belts
- D-4 Aircraft Information

**E. Belt-Positioning Booster Use.....** Pages 22-26

- E-1 Preparing Belt-Positioning Booster
- E-2 Installing Booster Seat with Backrest
- E-3 Installing Booster Seat without Backrest



## A-1 Thank You...

Thank you for choosing this car seat, referred to throughout this manual as a child restraint. The DJG family is committed to creating a child restraint with the most comfort and convenience available today.

Remember, parents are a child's first teachers and examples. If you always buckle your seat belt, your child will think it is the natural thing to do. Make it a firm rule that the vehicle does not go until everyone is buckled up. Make no exceptions.

No one can predict if use of a child restraint will prevent injury or death in a particular crash. However, combined with careful driving, proper use of a child restraint can lower a child's risk of injury or death in most crashes.

Your child's safety is worth the time it will take to read and follow these instructions. After reading, if you still have questions or have any problems with this child restraint, please contact our Consumer Relations Department at:

### Dorel Juvenile Group, Inc.

Website: [www.djgusa.com](http://www.djgusa.com)

Fax: 1-800-207-8182

Mailing Address: Dorel Juvenile Group, Inc.  
P.O. Box 2609  
Columbus, IN 47202-2609

Telephone: 1-800-544-1108

8 A.M. to 6 P.M. EST M-TH  
8 A.M. to 4:30 P.M. EST FRI

On the bottom of the base there is an expiration date for use of this child restraint. Do not use this child restraint after the expiration date.

Para recibir las instrucciones en español, llame al 1-800-544-1108 o solicítase por escrito al dirección por arriba.

## A-2 Registration and Safety Notices

Please complete the postage-paid registration card that came with your child restraint, and send it to us. Child restraints could be recalled for safety reasons. You must register this restraint to be reached in a recall. Send your name, address, email address if available, and the restraint's model number and manufacturing date to:

Dorel Juvenile Group, Inc.  
PO Box 2609, Columbus, IN 47202-2609  
Attn: Consumer Relations

or call 1-800-544-1108 or register online at [www.djgusa.com/registration/carseat/us](http://www.djgusa.com/registration/carseat/us).

For recall information, call the U.S. Government's Vehicle Safety Hotline at 1-888-327-4236 (TTY: 1-800-424-9153), or go to <http://www.NHTSA.gov>

Consumer: Just fill in your name, address and email. Please print (use dark ink).

Your Name \_\_\_\_\_

Your Street Address \_\_\_\_\_

State \_\_\_\_\_

Address (optional) \_\_\_\_\_

Model Number: BC027-ASW

Manufacture Date: 08/05/2010

**Example of model number and manufacture date.**

If you don't have the card or if your address changes, you will find the model number and manufactured date on the label located on side of plastic shell.



## A-3 Understanding Your Child Restraint

Front

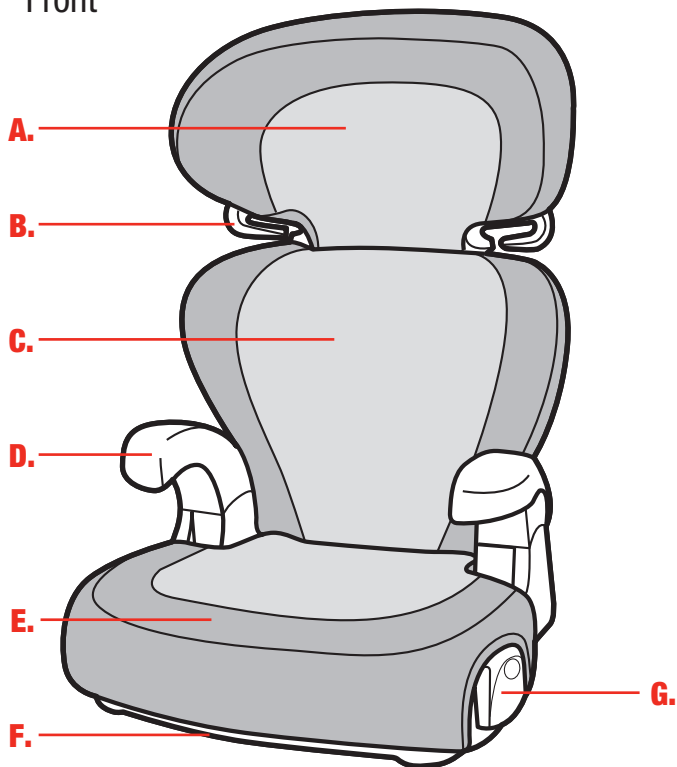

- A. Headrest**
- B. Shoulder Belt Positioning Guide**
- C. Backrest**
- D. Armrest**
- E. Seat Base**
- F. Instruction Manual Storage**  
(under seat base)

5

Back

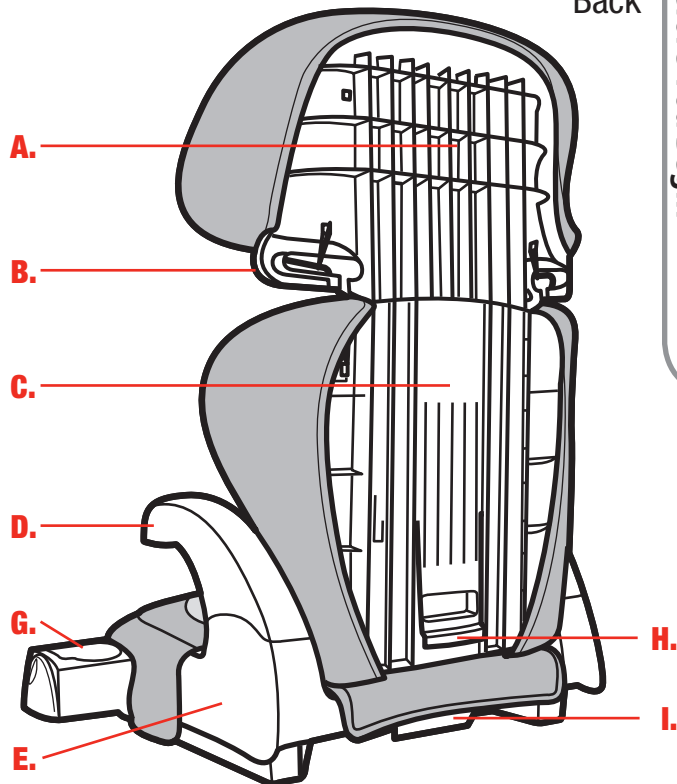

- G. Cup Holder**
- H. Headrest Adjustment Tab**
- I. Backrest Release Tab**  
(behind seat pad)

6

A. Before You Begin

## **⚠ WARNING:**

Failure to follow these warnings can result in the serious injury or death of your child. To help you recognize instructions which are most critical to your child's safety, we use this symbol: ⚠

### **B-1 Vehicle Seating Position**

- ⚠ Check the vehicle owner's manual for more information about airbag/child restraint use.
- ⚠ For vehicles without a back seat, refer to your vehicle owner's manual.

### **B-2 Installation in Vehicle**

- ⚠ Check the vehicle belt before each use. Use only if the belt is tightened properly and securely.
- ⚠ This child restraint should be securely belted in the vehicle even when not in use. In a crash or sudden stop, an unsecured child restraint could injure occupants.
- ⚠ Do not use a child restraint that has been in a crash. You must get a new child restraint.

### **B-3 Child Restraint Use**

- ⚠ Do not use this child restraint unless the child is 40-100 lbs (18.1- 45.4 kg), 43-57 in. (110.1-144.8 cm) and at least 4 years old.
- ⚠ Never take your child out of the child restraint while the vehicle is moving.
- ⚠ Never leave child unattended.
- ⚠ Placing your child in a hot child restraint may result in burns.
- ⚠ Do not use a child restraint with damaged or missing parts.
- ⚠ Do not substitute parts or try to modify the child restraint in any way.
- ⚠ Do not use any child restraint accessory except those approved by Dorel Juvenile Group.
- ⚠ Never allow any child to play with this child restraint; it is not a toy.
- ⚠ Do not remove or cover up any of the warning labels or other labels on the child restraint.
- ⚠ Read all instructions for additional warnings.

## C-1 Preparing Child Restraint

**NOTE:** Depending on your model, you may need to assemble you booster seat. Skip this section if already assembled.

### **⚠ WARNING:**

**Do not use this child restraint without the seat pad. Failure to do this can result in serious injury.**

Separate the backrest/headrest from the base. See section C-4. Remove the pad from the plastic bag.

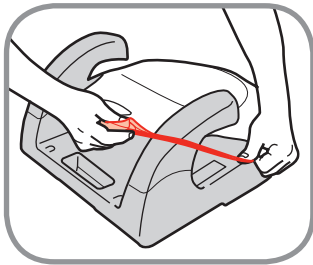

#### 1. Attach Base Seat Pad

Slide base pad onto the front of the base. Doing one side at a time, slide the elastic strap over the armrest.

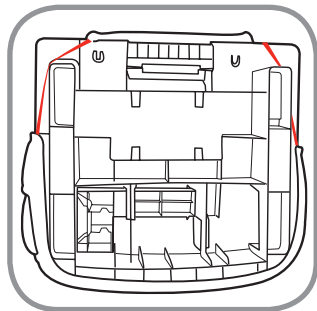

#### 2. Wrap Elastic Straps Under Base as Shown

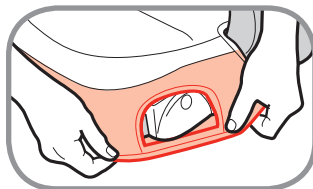

#### 3. Pull Pad Down and Around Cup Holder

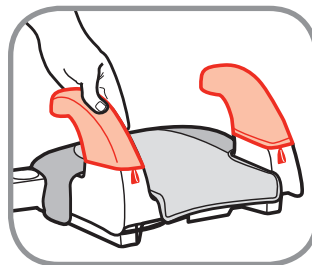

#### 4. Attach Arm Covers (on select models)

Slide armrest covers over armrests.

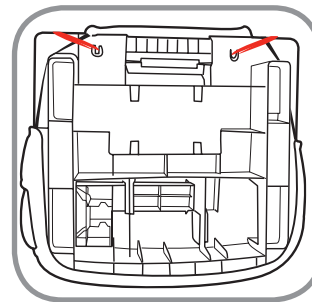

#### 5. Attach Elastic To Tab

Attach the elastic on back of armrest cover to bottom of base.

**To use the booster seat with backrest/headrest, follow all of the instructions below to attach the seat back.**

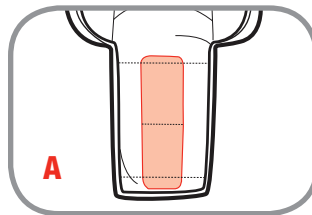

6. If the back of the headrest pad has a sewn on plastic strip (A), follow steps 7a-7d and steps 8-10.

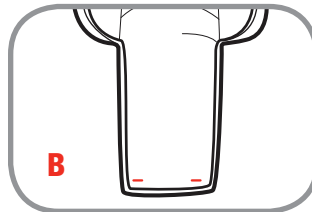

If the headrest pad does not have the plastic strip (B), skip to steps 7e-10.

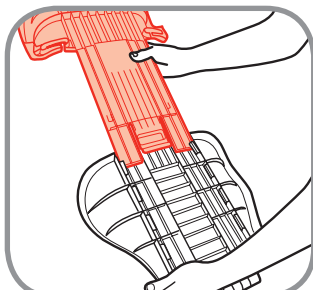

### 7a. Attach Headrest to Backrest

With the headrest and backrest facing down, slide the headrest into the track on the back of the headrest.

Lift headrest adjuster lock up and pull headrest down into a lock position.

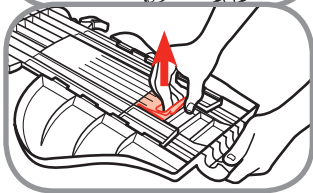

### 7b. Attach Headrest Pad

Attach headrest pad to the headrest by sliding the pad over one side of the headrest, then the other.

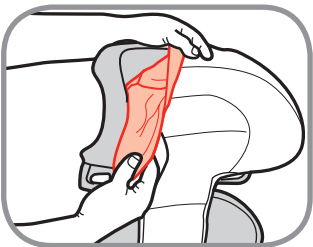

### 7c. Attach Elastic Straps

From the back of headrest, attach the elastic straps to the hooks above the shoulder belt positioning guide.

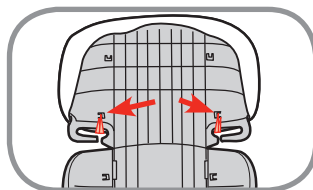

### 7d. Attach Backrest Pad

Slide backrest pad onto one side of the backrest. Pull pad tight and slide the pad over the other side of the backrest. Bottom of the headrest pad should be behind the backrest pad as shown.

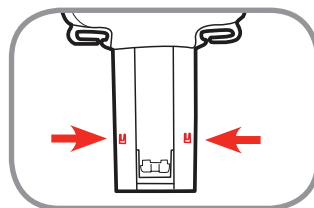
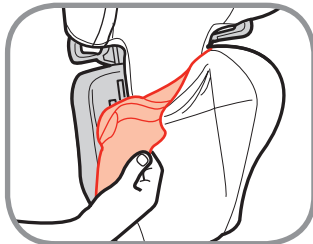

### 7e. Attach Headrest to Backrest

Attach headrest pad by attaching pad to tabs near the bottom of the headrest.

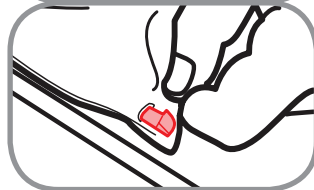

### 7f. Attach Headrest Pad

Attach headrest pad to the headrest by sliding the pad over one side of the headrest, then the other.

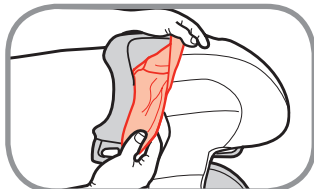

### 7g. Attach Elastic Straps

From the back of headrest, attach the elastic straps to the hooks above the shoulder belt positioning guide.

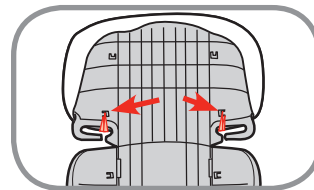

### 7h. Attach Headrest to Backrest

With the headrest and backrest facing down, slide the headrest into the track on the back of the headrest.

Lift headrest adjuster lock up and pull headrest down into a lock position.

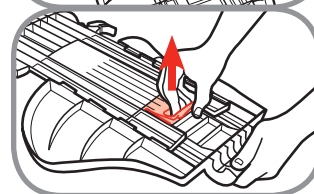
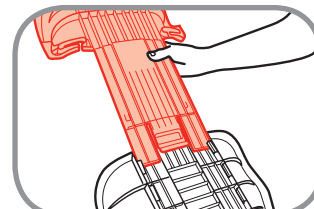

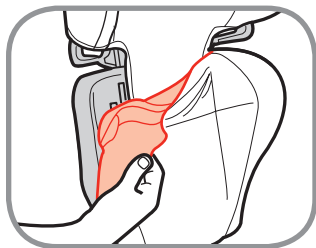

### 7i. Attach Backrest Pad

Slide backrest pad onto one side of the backrest. Pull pad tight and slide the pad over the other side of the backrest. Bottom of the headrest pad should be behind the backrest pad as shown.

## Attaching the Backrest

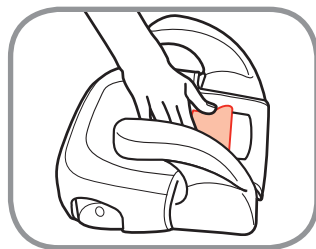

### 8. Open the Connection Hole

Hold the rectangular shaped flap on the rear of the seat base pad down to expose the backrest connection hole.

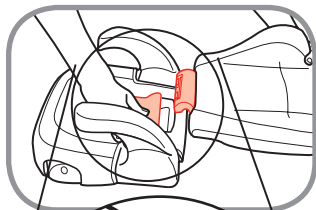

### 9. Attach Backrest to Base

Insert the hook on the backrest into the large opening on back of seat base. Make sure backrest is laying flat (horizontal) when connecting.

**NOTE:** Make sure seat pad does not get caught between the moving parts. The backrest may not connect properly if the pad is in the way.

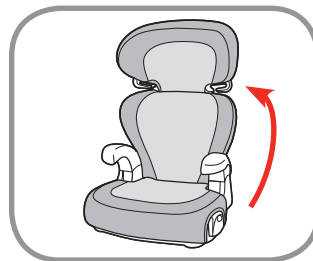

### 10. Rotate Backrest Up Until It Clicks

Tuck backrest hole flap under the backrest pad.

## C-2 Adjusting Headrest

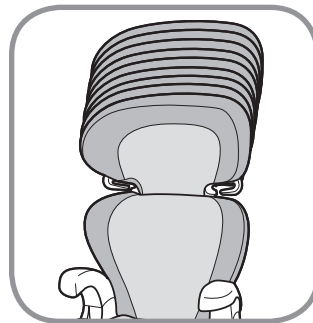

1. This child restraint has many headrest positions. The backrest/headrest are removable.

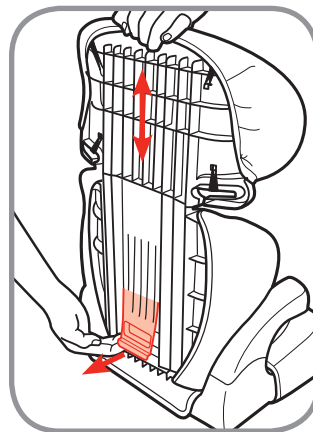

### 2. To Raise or Lower Headrest:

Grasp top of headrest and push down with one hand while pulling out on the headrest adjustment tab with the other.

Raise and lower headrest into selected position. Release the headrest adjustment tab into one of the many headrest heights.

Make sure headrest is locked by sliding headrest up and down. Headrest may move slightly when it is locked.

## C-3 Adjusting Backrest

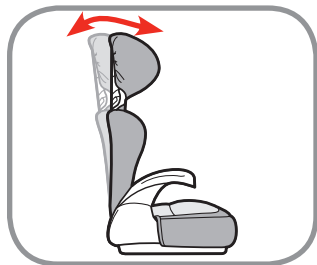

Backrest has 2 positions, upright and semi-reclined. The semi-recline position is to be used only to install the child restraint flush against the back of the vehicle seat back, if needed.

### To Recline the Backrest

Recline the backrest by pushing firmly on the backrest release tab and rotate top of seat back about an inch.

The restraint is now in semi-recline position.

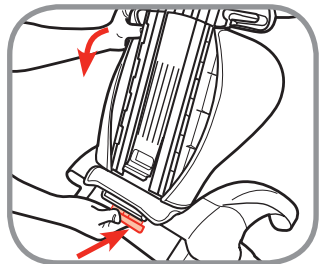

## C-4 Removing Backrest

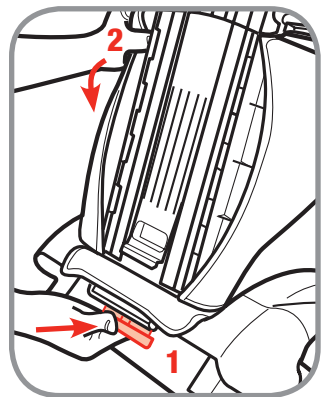

### 1. Press In on Backrest Release Tab

To remove backrest from seat base, backrest needs to be in the most upright position. Press firmly on backrest release tab and rotate seat back until it lays flat.

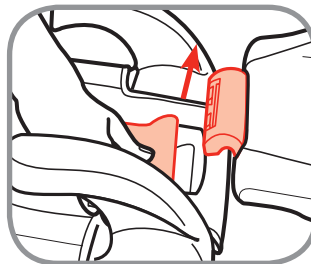

### 2. Remove Backrest from Base

Lift backrest hook out of the opening in seat base. Store backrest for future use.

Lay flap over hole where backrest connects to the base.

## C-5 Cup Holder

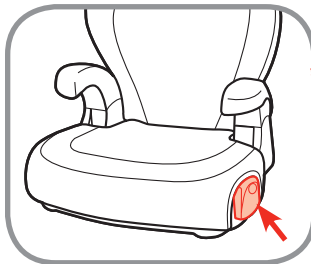

### 1. Locate Cup Holder

The cup holder is located in the base of the child restraint.

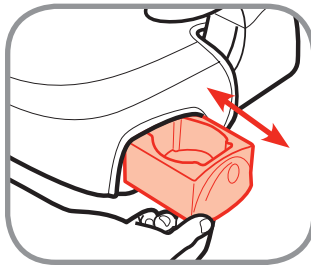

### 2. Pull out cup holder to use.

Push cup holder in when not needed.

## C-6 Removing Seat Pad for Cleaning

### **⚠ WARNING:**

**Do not use this child restraint without the seat pad. Failure to do this can result in serious injury.**

To remove pad, remove backrest from base. See section C-4.

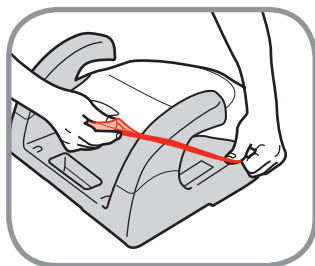

### **1. Remove Pad from Base**

Pull elastic straps out from under the base and pull the pad off the base.

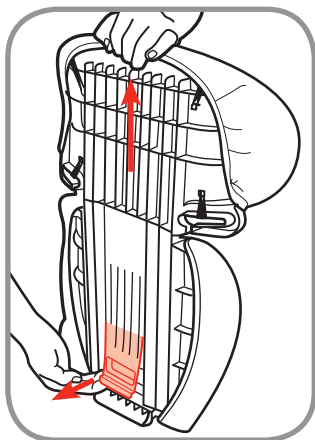

### **2. Remove Headrest from Backrest**

Grasp top of headrest and push down with one hand while pulling out on the headrest adjustment tab with the other.

Remove headrest.

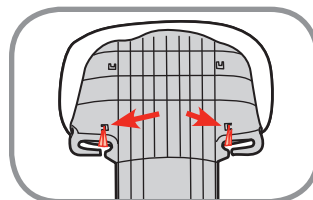

### **3. Remove Pad from Headrest**

From the back, remove the elastic from the back of the headrest.

Depending on your model, you may need to unhook bottom of pad from tabs near bottom of headrest.

Pull pad off of headrest.

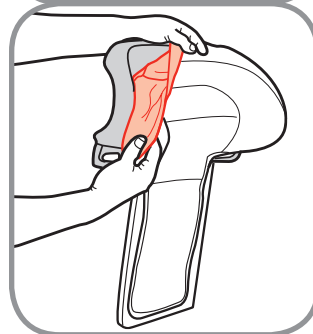

### **4. Remove Pad from Backrest**

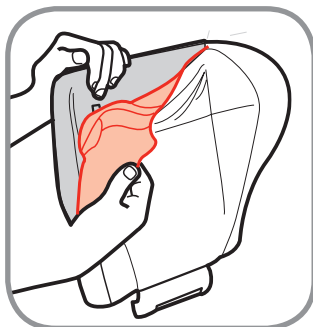

### **Remove Seat Pad**

Start by removing the arm cover (on select models), and then remove seat pad.

### **Cleaning Pad**

Hand wash pad with warm sudsy water, rinse clean and air dry. Do not use bleach or use other harsh cleaners. Do not dry clean.

### **Replacing Pad**

Follow steps in section C-1 to replace the pad.

## D-1 Understanding Your Vehicle

Your vehicle's features may be considerably different than those pictured here. Consult your vehicle owner's manual to help identify your vehicle's specific features and locations.

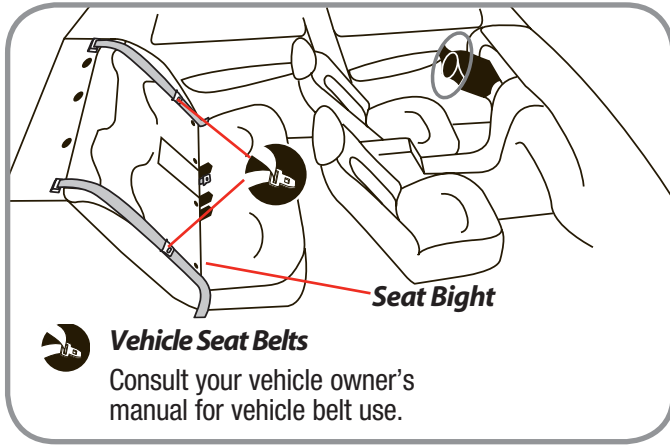

## D-2 Vehicle Seating Position

Some seating positions in your vehicle may not be safe for this child restraint. Some vehicles do not have a seating position that can be used safely with this child restraint. If you are not sure where to place the child restraint in your vehicle, consult your vehicle owner's manual or contact Dorel Juvenile Group Consumer Relations Department.

### **⚠ WARNING:**

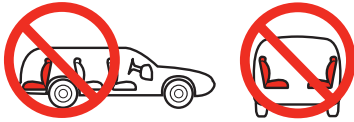

**Use the child restraint only on vehicle seats that face forward. Do not use on seats that face the sides or rear of the vehicle.**

## Safety Tip:



**Children are safer when properly restrained in rear seating positions than in the front seating positions.**

**According to National Highway Traffic Safety Administration information, children in rear seating positions are statistically safer, whether you have airbags, advanced airbags, or no airbags at all.**

**To avoid your child being seriously burned, take the following precautions:**

1. Park in the shade or where sun does not directly hit the child restraint.
2. Cover the child restraint with a sheet or blanket when not in use.

To help protect your vehicle seat's upholstery from damage, use a single layered towel underneath and behind child restraint.

## D-3 Knowing Your Vehicle Belts

Review your vehicle's owner manual for vehicle seat belt use with child restraints. This is your best source for information concerning your vehicle.

Not all vehicle belts will work with this child restraint. This child restraint must be tightly locked in place at all times during travel. You must determine if your vehicles belts are compatible with this child restraint. There are some vehicle belts that will not work with a child restraint or will require special attention.

## Vehicle Belts

### • Automatic/Passive Vehicle Seat Belts

You **MUST** have a vehicle lap belt to install any child restraint. An automatic (passive) shoulder vehicle belt may or may not have a separate vehicle lap belt. Consult your vehicle owner's manual.



### • Vehicle Belts in center of the door or side panel

You must move the child restraint to another seating location. Consult your vehicle owner's manual.



### • Vehicle Belts that are in front of the seat bight

You may need to move the child restraint to another seating location. Consult your vehicle owner's manual.

## D-4 Aircraft Information



**This child restraint is not certified for aircraft use.** Lap and shoulder belts are needed when using as a belt-positioning booster seat, which are not available on aircraft.

## E-1 Preparing Belt-Positioning Booster



Lap/Shoulder Belt

### Booster with Backrest:

**40-100 lbs (18.1-45.4 kg) 43-57 in. (110.1-144.8 cm) and at least 4 Years Old.**

Vehicle lap/shoulder belt combination. Child and child restraint face the front of the vehicle and are placed in the back seat.



Lap/Shoulder Belt

### Booster without Backrest:

**40-100 lbs (18.1-45.4 kg) 43-57 in. (110.1-144.8 cm) and at least 4 Years Old.**

Vehicle lap/shoulder belt combination. Child and child restraint face the front of the vehicle and are placed in the back seat.

### **⚠ WARNING:**

**Use only the vehicle's lap and shoulder belt system when restraining the child in this belt-positioning booster seat.**

**Failure to follow these warnings can result in serious injury or death.**



## E-2 Installing Booster Seat with Backrest



### 1. Place Belt-Positioning Booster Seat Forward-Facing in Vehicle

Center the child restraint in the chosen seating position. The back of the child restraint should be flat against the vehicle seat back.



### 2. Place Child in Seat

Child should sit with their bottom and back flat against the child restraint.



### 3. Buckle Lap and Shoulder Belt

Route lap portion of the lap/shoulder belt under both armrest. The shoulder belt must go under the armrest on the vehicle buckle side only.

Lock buckle.

Lap belt should cross the child's thighs and lay across their hips.



### 4. Secure Shoulder Belt

Secure the shoulder belt through the shoulder belt positioning guide in the headrest.

The shoulder belt should lay snugly across the center of the child's shoulder and across the chest (not on the face or

neck). Adjust headrest as needed (see section C-2). Pull up on the shoulder belt to tighten.

Check periodically to ensure your child has not moved out of position and loosened the shoulder belt.

## **⚠ WARNING:**

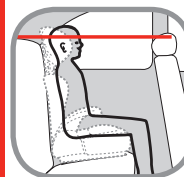

**Do not use this child restraint if the midpoint of your child's head is above the top of the vehicle seat back or vehicle headrest.**

**Check vehicle instructions for more information about airbag/child restraint use.**



**Do not use only the lap belt when using this seat.**

**The shoulder belt must always be adjusted snugly across the child's chest.**

**NEVER place the shoulder belt under the child's arms.**

**Failure to follow these warnings could cause serious injury or death to your child.**



## E-3 Installing Booster Seat without Backrest

Remove backrest from base. See section C-4.



### 1. Place Belt-Positioning Booster Seat Forward-Facing in Vehicle

Center the child restraint in the chosen seating position. The back of the child restraint should be flat against the vehicle seat back.



### 2. Place Child in Seat

Child should sit with their back flat against the vehicle seat and bottom flat against the seat base.



### 3. Buckle Lap and Shoulder Belt

Route lap portion of the lap/shoulder belt under both armrest. The shoulder belt must go under the armrest on the vehicle buckle side only.

Lock buckle.

Lap belt should cross the child's thighs and lay across their hips.



4. The shoulder belt should lay snugly across the center of the child's shoulder and across the chest (not on the face or neck).

Pull up on the shoulder belt to tighten.

Check periodically to ensure you child has not moved out of position and loosened the shoulder belt.

## **⚠ WARNING:**

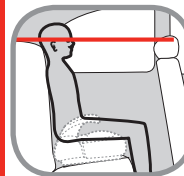

**Do not use this child restraint if the midpoint of your child's head is above the top of the vehicle seat back or vehicle headrest.**

**Check vehicle instructions for more information about airbag/child restraint use.**



**Do not use only the lap belt when using this seat.**

**The shoulder belt must always be adjusted snugly across the child's chest.**

**NEVER place the shoulder belt under the child's arms.**

**Failure to follow these warnings could cause serious injury or death to your child.**

## Troubleshooting

### **1. If your child restraint is not held securely by the vehicle belt:**

Remove all the slack in the vehicle belt. Make sure the belt buckle is not up against the child restraint where the belt cannot be tightened. If you cannot secure the child restraint tightly, move it to another seating location.

### **2. If the shoulder belt crosses the child's neck when using the child restraint:**

Try moving the child restraint toward the center of the vehicle or move the vehicle seat forward or back. Check to see if your vehicle has adjustable shoulder belt anchor points.

**Do not** place the shoulder belt behind the child.

## Warranty

Dorel Juvenile Group, Inc. (DJG) warrants this product to the original retail purchaser as follows:

This product is warranted against defective materials or workmanship for one year from the date of original purchase.

**An original receipt is required to validate your warranty.** DJG will, at its option, provide replacement parts or replace this product. DJG reserves the right to substitute if the part or model has been discontinued.

To make a claim under this warranty you may contact us at [www.djgusa.com](http://www.djgusa.com), fax us at 1-800-207-8182 24 hours a day, write to DJG, Consumer Relations Department, P. O. Box 2609, Columbus, IN 47202-2609, or call 1-800-544-1108 from 8:00 a.m. to 6:00 p.m. EST Monday through Thursday and from 8:00 a.m. to 4:30 p.m. on Friday. **Proof of purchase is required and shipping charges are the responsibility of the consumer.**

### **Warranty Limitations:**

This warranty does not include damages which arise from misuse or abuse of this product.

### **Limitation of Damages:**

The warranty and remedies as set forth are exclusive and in lieu of all others, oral or written, expressed or implied. In no event will DJG or the dealer selling this product be liable to you for any damages, including incidental or consequential damages, arising out of the use or inability to use this product.

### **Limitation of warranties and other warranty terms and state law rights:**

Any implied warranties, including implied warranties of the merchantability and fitness for a particular purpose, shall be limited to the duration and terms of the express written warranty. Some states do not allow limitations as to how long an implied warranty lasts or the exclusion or limitation of incidental or consequential damages, so the above limitations may not apply to you. This warranty gives you specific legal rights, and you may have other rights, which vary from state to state. Neither DJG nor the dealer selling this product authorized any person to create for it any other warranty, obligation, or liability in connection with this product.

## Replacement Parts Order Form

Complete the form below. Your model number with color code and manufacturer date code **MUST** be included on the form to ensure proper replacement parts. Your model number with color code and the date code can be found on a sticker on the side of child restraint. Payment in U.S. dollars must accompany your order. Choose parts needed from the list on the next page.

Return the form with payment to:

**Dorel Juvenile Group, Inc.**  
**Consumer Relations Department**  
**P.O. Box 2609**  
**Columbus, IN 47202-2609**

Fax orders to: 1-800-207-8182

Please make money orders payable to Dorel Juvenile Group, Inc. Fill in the area below to charge to Visa or Mastercard. We do not accept cash, personal checks, or Discover Card. All outside of U.S. and Canada **MUST** use credit card.

Ship To (Please Print): \_\_\_\_\_

Name: \_\_\_\_\_

Address: \_\_\_\_\_

City: \_\_\_\_\_

State/Province: \_\_\_\_\_ Zip \_\_\_\_\_

Telephone: \_\_\_\_\_

Email Address: \_\_\_\_\_

**We **MUST** have this information to process your order:**  
**Model Number (8 to 9 characters):** \_\_\_\_\_

**Manufacture Date (mm/dd/yyyy):** \_\_\_\_\_