

Wireless Noise Canceling Stereo Headset  
MDR-XB950N1



Use this manual if you encounter any problems, or have any questions.

## Getting started

What you can do with the BLUETOOTH function

About voice guidance

Supplied accessories

Checking the package contents

About the supplied manuals

Parts and controls

Location and function of parts

About the indicator

Charging the headset



System requirements for battery charge using USB

Charging the headset

Available operating time

Checking the remaining battery charge

## Making connections

### How to make a wireless connection to BLUETOOTH devices

#### One-touch connection (NFC) compatible Android devices

One-touch connection (NFC) with a smartphone (Android 4.1 or later)

Disconnecting the smartphone by one touch (NFC)

Switching the device by one touch (NFC)

#### Android devices not compatible with one-touch connection (NFC)

Pairing and connecting with an Android smartphone

Connecting to a paired Android smartphone

#### iPhone (iOS devices)

Pairing and connecting with an iPhone

Connecting to a paired iPhone

#### Computers

Pairing and connecting with a computer (Windows 10)

Pairing and connecting with a computer (Windows 8/Windows 8.1)

Pairing and connecting with a computer (Windows 7)

Connecting to a paired computer (Windows 10)

Connecting to a paired computer (Windows 8/Windows 8.1)

Connecting to a paired computer (Windows 7)

#### Other BLUETOOTH devices

Pairing and connecting with other BLUETOOTH devices

Connecting to a paired BLUETOOTH device

#### Multi point connection

Connecting the headset to both a music player and a smartphone or mobile phone

Connecting the headset to 2 Android smartphones



Connecting the headset to an Android smartphone and an iPhone



Using the supplied headphone cable

## Listening to music

Listening to music via a BLUETOOTH connection

Listening to music from a device connected via BLUETOOTH



Controlling the audio device (BLUETOOTH connection)



Disconnecting BLUETOOTH connection (after use)



Noise canceling function

What is noise canceling?



Using the noise canceling function



About the Automatic AI noise canceling function



Bass effect function

About the bass effect function



Using the bass effect function



Sound quality mode

Switching the sound quality mode



Checking the sound quality mode



Supported codecs

## Making phone calls

Receiving a call

Making a call

Functions for a phone call

Disconnecting BLUETOOTH connection (after use)

Using the voice assist function

Using the voice assist function (Siri)

Using the voice assist function (Google App)

Using the apps

## What you can do with "Sony | Headphones Connect" app

Installing "Sony | Headphones Connect" app

## Important information

Precautions

Trademarks

Customer support websites

## Troubleshooting

What can I do to solve a problem?

### Power/Charging

The headset is not turned on.

Charging cannot be done.

Charging time is too long.

The headset cannot be recognized by a computer.

The remaining battery charge of the headset is not displayed on the screen of an iPhone, iPad, or iPod touch.

### Sound

No sound

Low sound level

Low sound quality

Sound skips frequently during playback.

The noise canceling effect is not sufficient.

### BLUETOOTH

Pairing cannot be done.

Unable to connect the headset to a BLUETOOTH device with one-touch connection (NFC)

Unable to make a BLUETOOTH connection

Distorted sound

The BLUETOOTH wireless communication range is short, or the sound skips.

The headset does not operate properly.

No voice from callers

Low voice from callers

Resetting or initializing the headset

Resetting the headset

Initializing the headset to restore factory settings

# Table Of Contents

MDR-XB950N1 Help Guide.....	i
Getting started.....	i
What you can do with the BLUETOOTH function.....	1
About voice guidance.....	2
Supplied accessories.....	i
Checking the package contents.....	3
About the supplied manuals.....	4
Parts and controls.....	i
Location and function of parts.....	5
About the indicator.....	7
Charging the headset.....	i
System requirements for battery charge using USB.....	9
Charging the headset.....	10
Available operating time.....	12
Checking the remaining battery charge.....	13
Making connections.....	ii
How to make a wireless connection to BLUETOOTH devices.....	15
One-touch connection (NFC) compatible Android devices.....	ii
One-touch connection (NFC) with a smartphone (Android 4.1 or later).....	16
Disconnecting the smartphone by one touch (NFC).....	18
Switching the device by one touch (NFC).....	19
Android devices not compatible with one-touch connection (NFC).....	ii
Pairing and connecting with an Android smartphone.....	20
Connecting to a paired Android smartphone.....	23
iPhone (iOS devices).....	ii
Pairing and connecting with an iPhone.....	26
Connecting to a paired iPhone.....	29
Computers.....	ii
Pairing and connecting with a computer (Windows 10).....	32
Pairing and connecting with a computer (Windows 8/Windows 8.1).....	36
Pairing and connecting with a computer (Windows 7).....	39
Connecting to a paired computer (Windows 10).....	42
Connecting to a paired computer (Windows 8/Windows 8.1).....	45
Connecting to a paired computer (Windows 7).....	49
Other BLUETOOTH devices.....	ii
Pairing and connecting with other BLUETOOTH devices.....	51
Connecting to a paired BLUETOOTH device.....	53
Multi point connection.....	ii

Connecting the headset to both a music player and a smartphone or mobile phone.....	55
Connecting the headset to 2 Android smartphones.....	56
Connecting the headset to an Android smartphone and an iPhone.....	58
Using the supplied headphone cable.....	60
Listening to music.....	iii
Listening to music via a BLUETOOTH connection.....	iii
Listening to music from a device connected via BLUETOOTH.....	61
Controlling the audio device (BLUETOOTH connection).....	63
Disconnecting BLUETOOTH connection (after use).....	64
Noise canceling function.....	iii
What is noise canceling?.....	65
Using the noise canceling function.....	66
About the Automatic AI noise canceling function.....	68
Bass effect function.....	iii
About the bass effect function.....	69
Using the bass effect function.....	70
Sound quality mode.....	iii
Switching the sound quality mode.....	71
Checking the sound quality mode.....	73
Supported codecs.....	74
Making phone calls.....	iii
Receiving a call.....	75
Making a call.....	77
Functions for a phone call.....	79
Disconnecting BLUETOOTH connection (after use).....	64
Using the voice assist function.....	iii
Using the voice assist function (Siri).....	81
Using the voice assist function (Google App).....	82
Using the apps.....	iii
What you can do with "Sony   Headphones Connect" app.....	83
Installing "Sony   Headphones Connect" app.....	84
Important information.....	iv
Precautions.....	85
Trademarks.....	86
Customer support websites.....	87
Troubleshooting.....	iv
What can I do to solve a problem?.....	88
Power/Charging.....	iv
The headset is not turned on.....	89

Charging cannot be done.....	90
Charging time is too long.....	91
The headset cannot be recognized by a computer.....	92
The remaining battery charge of the headset is not displayed on the screen of an iPhone, iPad, or iPod touch.....	93
Sound.....	iv
No sound.....	94
Low sound level.....	95
Low sound quality.....	96
Sound skips frequently during playback.....	97
The noise canceling effect is not sufficient.....	98
BLUETOOTH.....	iv
Pairing cannot be done.....	99
Unable to connect the headset to a BLUETOOTH device with one-touch connection (NFC).....	100
Unable to make a BLUETOOTH connection.....	101
Distorted sound.....	102
The BLUETOOTH wireless communication range is short, or the sound skips.....	103
The headset does not operate properly.....	104
No voice from callers.....	105
Low voice from callers.....	106
Resetting or initializing the headset.....	v
Resetting the headset.....	107
Initializing the headset to restore factory settings.....	108

Wireless Noise Canceling Stereo Headset  
MDR-XB950N1

## What you can do with the BLUETOOTH function

---

The headset uses BLUETOOTH wireless technology, allowing you to listen to music or make phone calls wirelessly.

### Listening to music

You can receive audio signals from a smartphone, mobile phone, or music player to enjoy music wirelessly.



### Talking on the phone

You can make and receive a call with your hands free, while leaving your smartphone or mobile phone in your bag or pocket.



Wireless Noise Canceling Stereo Headset  
MDR-XB950N1

## About voice guidance

---

You hear voice guidance on the following situations via the headset.

- When powering on: “Power on”
- When powering off: “Power off”
- When entering pairing mode: “BLUETOOTH pairing”
- When establishing a BLUETOOTH connection: “BLUETOOTH connected”
- When disconnecting a BLUETOOTH connection: “BLUETOOTH disconnected”
- When checking the remaining battery charge by pressing the  button when turned on: “Battery level high” / “Battery level medium” / “Battery level low”
- When automatically turning off due to the low battery condition: “Please recharge headset”
- When turning on the noise canceling function: “Noise canceling on”
- When turning off the noise canceling function: “Noise canceling off”
- When turning on the bass effect function: “Bass effect on”
- When turning off the bass effect function: “Bass effect off”

Wireless Noise Canceling Stereo Headset  
MDR-XB950N1

## Checking the package contents

---

After opening the package, check that all items in the list are included in the package. If items are missing, contact your dealer. Numbers in ( ) indicate the item amount.

Wireless Noise Canceling Stereo Headset (1)  
Micro-USB cable (approx. 50 cm (19 3/4 in.)) (1)

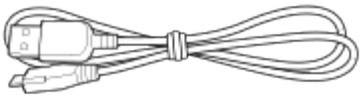

Headphone cable (approx. 1.2 m (47 1/4 in.)) (1)

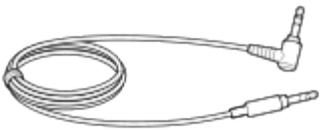

Carrying pouch (1)

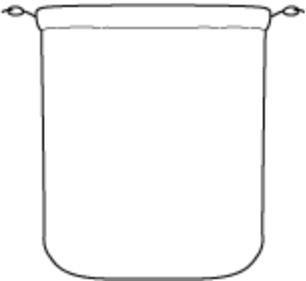

Reference Guide (1)  
Operating Instructions (1)  
Other documents (1 set) (\*)

\* May not be supplied in some countries or regions.

Wireless Noise Canceling Stereo Headset  
MDR-XB950N1

## About the supplied manuals

---

The following three manuals come with the headset.

### Help Guide (this data)



Operation manual on the Web, which can be accessed by a PC or smartphone, provides the detailed information on how to use the headset and troubleshooting, etc.

### Operating Instructions (enclosed paper)



Provides basic information on how to connect or use the headset.

### Reference Guide (enclosed paper)



Provides precautions and specifications.

Wireless Noise Canceling Stereo Headset  
MDR-XB950N1

Location and function of parts

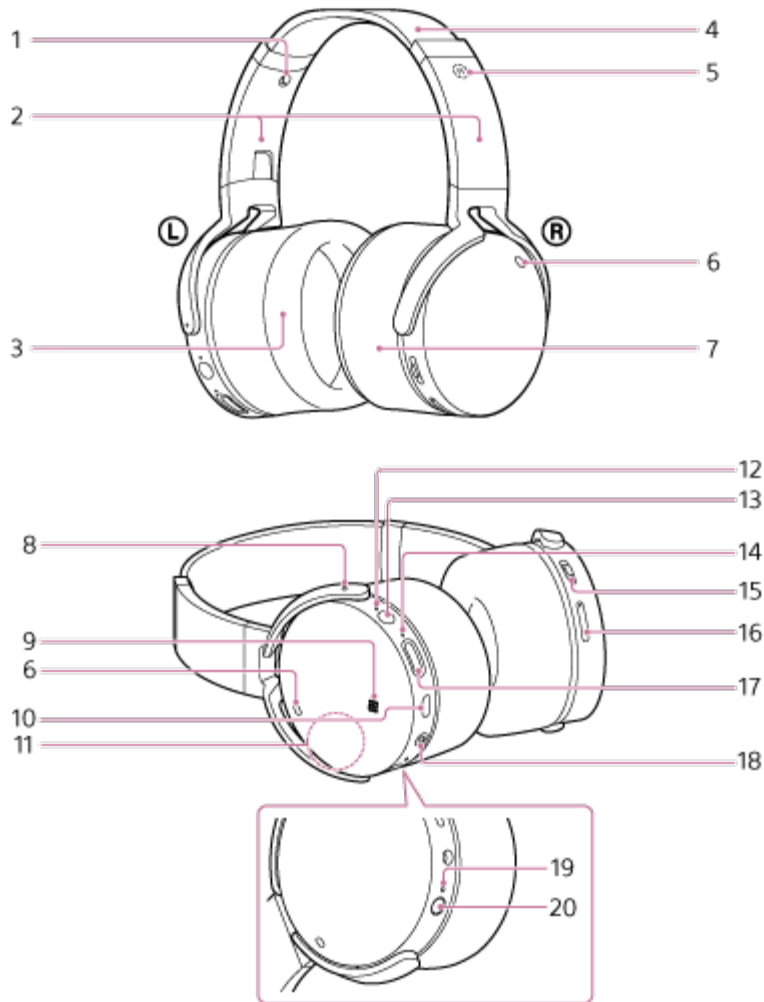

- 1. L mark
- 2. Slider
- 3. Ⓛ left unit
- 4. Headband
- 5. R mark
- 6. Microphone

Slide to adjust the length of the headband.

Picks up the sound of your voice when talking on the phone and suppresses noise when using the noise canceling function. Both of the L and R microphones are used when talking on the phone.

- 7. Ⓜ right unit
- 8. Tactile dot

The left unit has a tactile dot.

9. N-mark

10 Micro-USB port

· Connect a computer to this port with the supplied micro-USB cable to charge the headset.

11 Built-in antenna

· A BLUETOOTH antenna is built into the headset.

12 Indicator (blue/red)

· Lights up in red while charging.

· Lights up in red and blue to indicate the power on/off, remaining battery charge or BLUETOOTH status of the headset.

13  (power) button

14 BASS EFFECT indicator (orange)

· Lights up when the bass effect function is turned on.

15 Jog switch (  )

· Controls various call and playback functions.

16 +/- (Volume) buttons

· The + button has a tactile dot.

17 BASS EFFECT button

· Turns on or off the bass effect function.

18 INPUT jack

· Connect a music player, etc. to this jack by using the supplied headphone cable. Make sure that you insert the plug of the music player until it clicks. Otherwise, you may not hear the sound normally.

19 NC (noise canceling) indicator (green)

· Shows the noise canceling status.

20 NC button

---

Related Topic

- [About the indicator](#)
- [Checking the remaining battery charge](#)

Wireless Noise Canceling Stereo Headset  
MDR-XB950N1

## About the indicator

---

The indicator flashes in red, blue, green or orange to indicate various statuses.

●: Turns on in blue/●: Turns on in red/●: Turns on in green/●: Turns on in orange/-: Turns off

### Indicator (blue/red) next to the button

#### Turning on

- When turning on the headset by pressing and holding the  button for about 2 seconds when the headset is turned off.

● - ● (flashes two times)

#### Turning off

- When turning off the headset by pressing and holding the  button for about 2 seconds when the headset is turned on.

 (lights for about two seconds)

### BLUETOOTH status indication

- Pairing mode  
(Pressing and holding the  button for about 7 seconds when the headset is turned off)

● ● ● ● ● ● ● ● ● ●



- Not connected  
● - - ● - - ● - - ● (one-second intervals)

- Connection process completed  
● ● ● ● ● ● ● ● (flashes quickly for about five seconds)

- Connected  
● - - - (about five-second interval) --- ●



- Incoming call  
● ● ● ● ● ● ● ●

### Sound quality mode indication

- Priority on sound quality  

- Priority on stable connection  



For details, refer to [“Switching the sound quality mode.”](#)

## Remaining battery charge indication

- High  

- Medium  

- Low (needs to charge)  

For details, refer to [“Checking the remaining battery charge.”](#)

## Charging

- While charging  



## Other

- Initialization completed  

For details, refer to [“Initializing the headset to restore factory settings.”](#)

Indicator (green) next to the NC button



## Noise canceling function

- Noise canceling on  

- Noise canceling off  

For details, refer to [“What is noise canceling?.”](#)

Indicator (orange) next to the BASS EFFECT button

## Bass effect function

- Bass effect on  

- Bass effect off  

For details, refer to [“Using the bass effect function.”](#)

### Hint

- When the remaining battery charge becomes low, the indicator turns from blue to red, except for pairing mode.

Wireless Noise Canceling Stereo Headset  
MDR-XB950N1

## System requirements for battery charge using USB

---

The headset contains a lithium ion rechargeable battery, which should be charged before using the headset for the first time.

Personal Computer with pre-installed with any of the following operating systems and USB port:

- When using Windows®
  - Windows® 10 Home / Windows® 10 Pro
  - Windows® 8.1 / Windows® 8.1 Pro
  - Windows® 8 / Windows® 8 Pro
  - Windows® 7 Home Basic / Home Premium / Professional / Ultimate
- When using Mac
  - Mac OS X (version 10.8 or later)

### Note

- Sony does not guarantee proper operation in all system environments.
- When using Windows 8.1 update using Windows Update.

Wireless Noise Canceling Stereo Headset  
MDR-XB950N1

## Charging the headset

The headset contains a lithium ion rechargeable battery. Charge the headset using the supplied micro-USB cable.

- 1 Connect the supplied micro-USB cable to the headset, and then connect the other end to a booted computer.

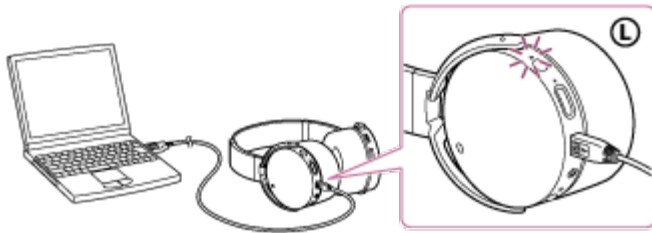

- Make sure that the indicator (red) lights up.
- Charging is completed in about 7 hours (\*) and the indicator (red) goes off automatically.

\* Time required for charging the empty battery to its full capacity.

### Note

- The headset cannot be operated (turning on, BLUETOOTH pairing and connection, music playback, etc.) while charging or if kept connected to the computer after charging is complete.
- The noise canceling function cannot be used while charging or if kept connected to the computer after charging is complete.
- If the headset detects a problem while charging due to following causes, the indicator (red) may turn off, although charging is not complete. In this case, charge again within the charging temperature range. If the problem persists, consult your nearest Sony dealer.
  - Ambient temperature exceeds the charging temperature range of 5 °C – 35 °C(41 °F - 95 °F).
  - There is a problem with the battery.
- If the headset is not used for a long time, the indicator (red) may not light up when you connect the micro-USB cable to charge the headset. In this case, do not disconnect the micro-USB cable from the headset: wait a few minutes until the indicator (red) lights up.
- If the headset is not used for a long time, the battery may be quickly depleted, however, after a few recharges, the battery life will improve.
- If you store the headset for a long time, charge the battery to its full capacity once every 6 months to avoid over discharge.
- If the headset is not used for a long time, it may take longer to charge the battery.
- If the life of the built-in rechargeable battery drops significantly, the battery should be replaced. Consult your nearest Sony dealer for replacement of the rechargeable battery.
- Avoid exposure to temperature extremes, direct sunlight, moisture, sand, dust or mechanical shock. Never leave the headset in a car parked in the sun.

- If the computer enters into hibernation mode while connected to the headset, charging will not be completed properly. Check the setting of the computer before charging. The indicator (red) will go off automatically if the computer enters into hibernation mode. Charge the headset again in this case.
- Use the supplied micro-USB cable only, and connect directly to a computer. Charging will not be completed properly by an indirect connection, such as via a USB hub.

### Hint

- You can use the headset by connecting the supplied headphone cable, even while charging the headset.
- If charging starts while the headset is turned on, the headset will turn off automatically.

Wireless Noise Canceling Stereo Headset  
MDR-XB950N1

## Available operating time

---

The available operating times of the headset on a fully-charged battery are as follows:

- Wireless connection
  - Music Playback time [SBC/AAC]: Max. 22 hours (NC ON)/Max. 24 hours (NC OFF)
  - Music Playback time [aptX]: Max. 20 hours (NC ON)/Max. 22 hours (NC OFF)
  - Communication time: Max. 20 hours (NC ON)/Max. 20 hours (NC OFF)
  - Standby time: Max. 20 hours (NC ON)/Max. 40 hours (NC OFF)

This headset can be used for about 3 hours after 1 hour charging.

- Wired connection (Power on): Max. 20 hours (NC ON)

### Note

- Usage hours may be shorter depending on the Codec and the conditions of use.

Wireless Noise Canceling Stereo Headset  
MDR-XB950N1

## Checking the remaining battery charge

You can check the remaining battery charge of the rechargeable battery.

When you turn on the headset by pressing the button, the indicator (blue) flashes two times, then the indicator (red) flashes. You can check the remaining battery charge by the number of times the indicator (red) flashes.

You can also check the remaining battery charge when the headset is turned on. Pressing the button will cause the indicator to flash and show the remaining battery charge. You also hear voice guidance of the remaining battery charge.

- 3 times - - : High "Battery level high"
- 2 times - : Medium "Battery level medium"
- 1 time : Low (needs to charge) "Battery level low"

### When the battery is almost empty

The indicator turns red. When the battery becomes empty, the headset sounds a warning beep, you hear voice guidance "Please recharge headset", and the head set turns off automatically.

### When you are using an iPhone, iPad, or iPod touch

When the headset is connected to an iPhone, iPad, or iPod touch (iOS 5.0 or later) that supports HFP (Hands-free Profile), it will show an icon that indicates the remaining battery charge of the headset on the screen.

Compatible devices

- iPhone, iPad, or iPod touch (iOS 5.0 or later) supporting Hands-free Profile (HFP)
- iOS 7.0 or later

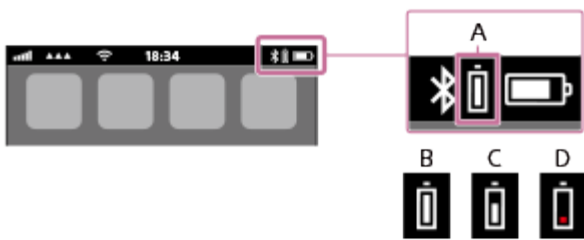

iOS 5.X / 6.X

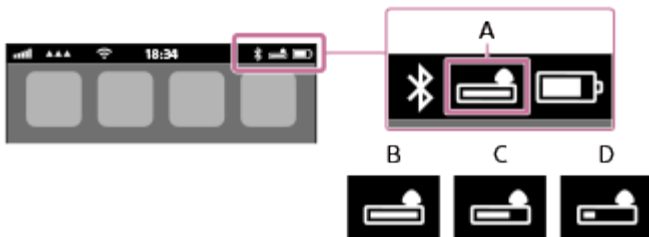

- A: Remaining battery charge of the headset
- B: High
- C: Medium

D: Low (needs to charge)

### Note

- If you connect the headset to an iPhone, iPad or iPod touch with "Media audio" (A2DP) only in a multi point connection, the remaining battery charge will not be displayed correctly.

### Hint

- You can also check the remaining battery charge with the "Sony | Headphones Connect" app.

---

### Related Topic

- [What you can do with "Sony | Headphones Connect" app](#)

Wireless Noise Canceling Stereo Headset  
MDR-XB950N1

## How to make a wireless connection to BLUETOOTH devices

---

### Device registration (pairing)

When using the BLUETOOTH function for the first time, you must previously register both devices to allow connection. The operation to register a device is called device registration (pairing).

If the device to be connected does not support the one-touch connection (NFC), operate the headset and the device to perform device registration (pairing).

If the device supports one-touch connection (NFC), you can just touch to perform device registration (pairing) and establish a BLUETOOTH connection.

### Connecting the headset to a registered (paired) device

When the device is registered, it is not necessary to register it again. Connect to it with an appropriate method.

Wireless Noise Canceling Stereo Headset  
MDR-XB950N1

## One-touch connection (NFC) with a smartphone (Android 4.1 or later)

---

By touching the headset with a smartphone, the headset turns on automatically and then pairs and makes a BLUETOOTH connection.

### Compatible smartphones

NFC-compatible smartphones installed with Android 4.1 or later

### NFC

NFC (Near Field Communication) is a technology enabling short-range wireless communication between various devices, such as smartphones and IC tags. Thanks to the NFC function, data communication - for example, BLUETOOTH pairing - can be achieved easily by simply touching NFC-compatible devices together (i.e., at the N-Mark symbol or location designated on each device).

1 Unlock the screen of the smartphone if it is locked.

2 Select [Setting] — [More].

3 Set the NFC function to on.



\* The above procedure is an example. For details, refer to the operating instructions supplied with your Android smartphone.

4 Touch the headset with the smartphone.

- Touch the smartphone on the N-Mark of the headset. Keep touching the headset with the smartphone until the smartphone reacts.
- Refer to the operating instructions of the smartphone for the designated location to be touched on the smartphone.

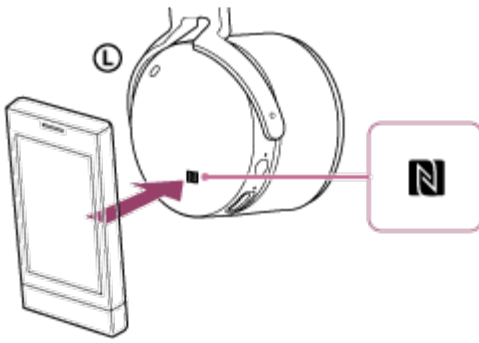

Follow the on-screen instructions to complete the pairing and connection.

When the headset is connected with the smartphone, the blue indicator starts flashing slowly. You hear voice guidance “BLUETOOTH connected”.

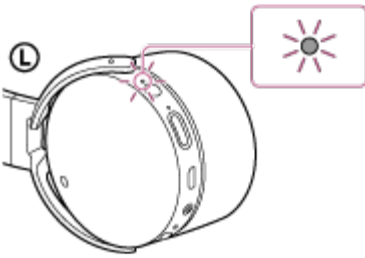

- To disconnect, touch the smartphone again. Unlock the screen of the smartphone if it is locked.
- To connect a paired smartphone, perform step 4. Unlock the screen of the smartphone if it is locked.

#### Hint

- If you cannot connect the headset, try the following.
  - Unlock the screen of the smartphone if it is locked, and move the smartphone slowly over the N-Mark of the headset.
  - If the smartphone is in a case, remove the case.
- If you touch an NFC-compatible smartphone with the headset, the smartphone terminates BLUETOOTH connection with any current device, and connects to the headset (One-touch connection switching).

#### Related Topic

- [How to make a wireless connection to BLUETOOTH devices](#)
- [Disconnecting the smartphone by one touch \(NFC\)](#)
- [Switching the device by one touch \(NFC\)](#)
- [Listening to music from a device connected via BLUETOOTH](#)

Wireless Noise Canceling Stereo Headset  
MDR-XB950N1

## Disconnecting the smartphone by one touch (NFC)

---

You can disconnect the headset from the connected smartphone by touching the headset with it.

1 Unlock the screen of the smartphone if it is locked.

2 Touch the headset with the smartphone.

Touch the smartphone on the N-Mark of the headset. You hear voice guidance "BLUETOOTH disconnected".

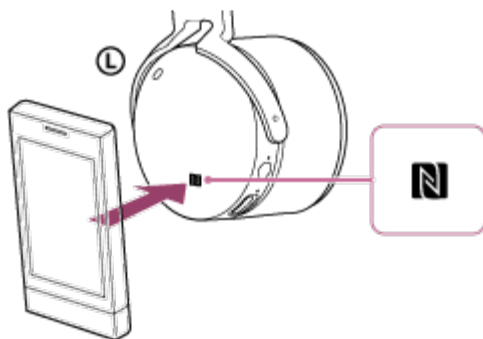

### Note

- After the headset is disconnected from the smartphone, if no operation is performed for about 5 minutes, the headset turns off automatically. To turn off the headset before that, press and hold the  button for about 2 seconds. You hear voice guidance "Power off", the indicator (blue) goes off, then the headset turns off.

Wireless Noise Canceling Stereo Headset  
MDR-XB950N1

## Switching the device by one touch (NFC)

---

- When the headset is connected with a BLUETOOTH device, if you touch an NFC-compatible smartphone on the headset, the headset is connected with the smartphone that touched on the headset most recently (One-touch connection switching). However, if you are talking on a BLUETOOTH mobile phone connected to the headset, you cannot switch the BLUETOOTH connection by one touch.
- When the headset is connected with an NFC-compatible smartphone, if you touch the smartphone on another NFC-compatible BLUETOOTH headset or BLUETOOTH speaker, the smartphone disconnects from the headset, and connects to the BLUETOOTH device it touched.

### Note

- Unlock the screen of the smartphone if it is locked.

Wireless Noise Canceling Stereo Headset  
MDR-XB950N1

## Pairing and connecting with an Android smartphone

Pairing is the process required to create a link between BLUETOOTH devices to allow wireless connection. You must pair a device with the headset to be able to make a BLUETOOTH connection for the first time. Before you start pairing operation, make sure that:

- The smartphone is placed within 1 m(3 feet) of the headset.
- The headset is charged sufficiently.
- The operating instructions of the smartphone is on hand.

### 1 Enter pairing mode on this headset.

When you pair the headset with a device for the first time after you bought it, or after you initialized the headset (the headset has no pairing information), press and hold the  button for about 2 seconds when the headset is turned off. The headset enters pairing mode automatically.

When you pair a 2nd or subsequent device (the headset has pairing information for other devices), press and hold the  button for about 7 seconds.

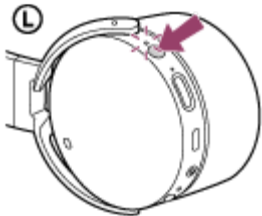

Make sure that the indicator flashes blue and red alternately after you release the button. You hear voice guidance "BLUETOOTH pairing".

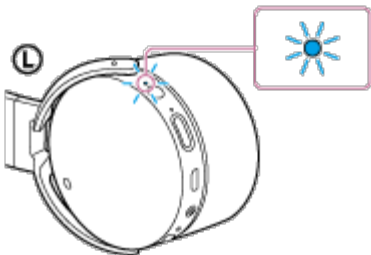

### 2 Unlock the screen of the Android smartphone if it is locked.

### 3 Search for this headset on the smartphone.

1. Select [Setting] - [Bluetooth].

Touch [  ] next to [Bluetooth] to turn on the BLUETOOTH function.

2. 

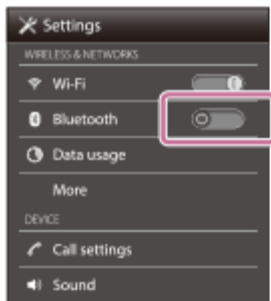

3. Touch [Bluetooth].

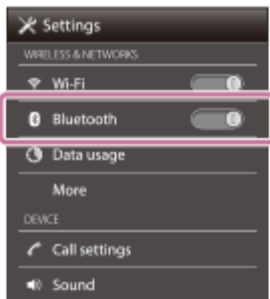

4. Touch [Search for devices].

5. Touch [MDR-XB950N1].



If passkey (\*) input is required on the display of the smartphone, input “0000.”

The headset and the smartphone are paired with each other and connected. You hear voice guidance “BLUETOOTH connected”.

If they are not connected, see [“Connecting to a paired Android smartphone.”](#)

If [MDR-XB950N1] does not appear on the display, try again from step 3.

\* A Passkey may be called a “Passcode,” a “PIN code,” or a “Password.”

## Note

- If pairing is not established within about 5 minutes, pairing mode will be canceled and the headset will turn off. In this case, start over from step 1.

- Once BLUETOOTH devices are paired, there is no need to pair them again, except in the following cases:
  - Pairing information has been deleted after repair, etc.
  - The headset is already paired with 8 devices and another device is to be paired.  
The headset can be paired with up to 8 devices. If a new device is paired after 8 devices are already paired, the paired device with the oldest connection time is replaced by the new one.
  - When the pairing information for the headset has been deleted from the BLUETOOTH device.
  - When the headset is initialized, all pairing information is deleted.  
In this case, delete the pairing information of the headset from the BLUETOOTH device, and then pair them again.
- The headset can be paired with multiple devices, but can only play music from one paired device at a time.

## Hint

- The above procedure is an example. For details, refer to the operating instructions supplied with your Android smartphone.
- To delete all pairing information, see “[Initializing the headset to restore factory settings.](#)”

---

## Related Topic

- [How to make a wireless connection to BLUETOOTH devices](#)
- [Connecting to a paired Android smartphone](#)
- [Listening to music from a device connected via BLUETOOTH](#)
- [Initializing the headset to restore factory settings](#)

Wireless Noise Canceling Stereo Headset  
MDR-XB950N1

## Connecting to a paired Android smartphone

---

1 Unlock the screen of the Android smartphone if it is locked.

2 Turn on the headset.

Press and hold the  button for about 2 seconds.

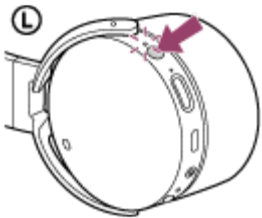

Make sure that the indicator (blue) flashes after you release the button. You hear voice guidance "Power on".

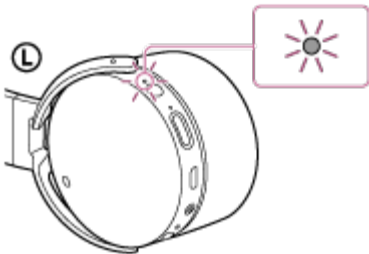

After the headset turns on, if it has automatically connected to the last connected device, you hear voice guidance "BLUETOOTH connected".

Check the connection status on the Android smartphone. If not connected, proceed to step 3.

3 Display the devices paired with the smartphone.

1. Select [Setting] - [Bluetooth].
2. Touch [  ] next to [Bluetooth] to turn on the BLUETOOTH function.

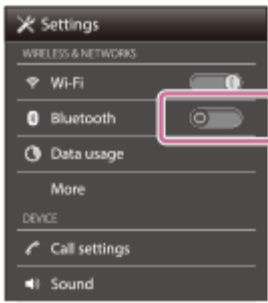

### 3. Touch [Bluetooth].

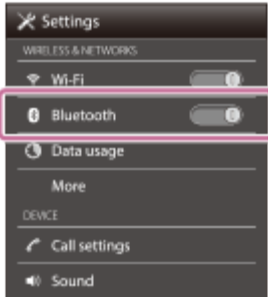

### 4 Touch [MDR-XB950N1].

You hear voice guidance “BLUETOOTH connected”.



#### Hint

- The above procedure is an example. For details, refer to the operating instructions supplied with your smartphone.
- If the smartphone was connected with the headset the last time, an HFP/HSP connection is made when you turn on the headset. While the headset is on, you can make an A2DP connection (music playback) by pressing the ►|| button.

#### Note

- If the last-connected BLUETOOTH device is put near the headset, the headset may connect automatically to the device by simply turning on the headset. In this case, deactivate the BLUETOOTH function on the BLUETOOTH device or turn off the power.
- If you cannot connect your BLUETOOTH device to the headset, deactivate pairing on your BLUETOOTH device and perform pairing again. For details, refer to the operating instructions supplied with your BLUETOOTH device.

---

## Related Topic

- [How to make a wireless connection to BLUETOOTH devices](#)
- [Pairing and connecting with an Android smartphone](#)
- [Listening to music from a device connected via BLUETOOTH](#)

4-692-591-11(1) Copyright 2017 Sony Corporation

Wireless Noise Canceling Stereo Headset  
MDR-XB950N1

## Pairing and connecting with an iPhone

Pairing is the process required to create a link between BLUETOOTH devices to allow wireless connection. You must pair a device with the headset to be able to make a BLUETOOTH connection for the first time. Before you start pairing operation, make sure that:

- The iPhone is placed within 1 m(3 feet) of the headset.
- The headset is charged sufficiently.
- The operating instructions of the iPhone is on hand.

### 1 Enter pairing mode on this headset.

When you pair the headset with a device for the first time after you bought it, or after you initialized the headset (the headset has no pairing information), press and hold the  button for about 2 seconds when the headset is turned off. The headset enters pairing mode automatically.

When you pair a 2nd or subsequent device (the headset has pairing information for other devices), press and hold the  button for about 7 seconds.

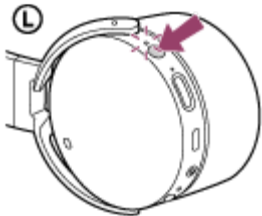

Make sure that the indicator flashes blue and red alternately after you release the button. You hear voice guidance "BLUETOOTH pairing".

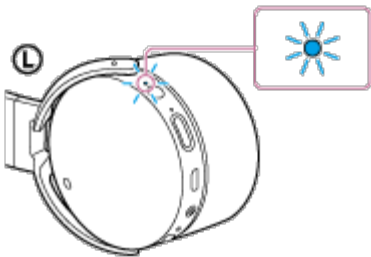

### 2 Unlock the screen of the iPhone if it is locked.

### 3 Select the BLUETOOTH setting on the iPhone.

1. Select [Settings].  
Touch [Bluetooth].

2.



3. Touch [  ] to change it to [  ] (turn on the BLUETOOTH function).

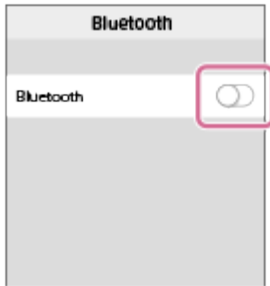

4 Touch [MDR-XB950N1].

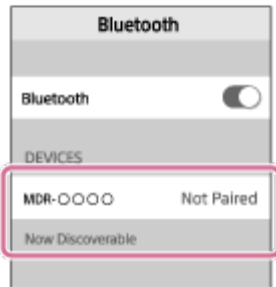

If passkey (\*) input is required on the display of the iPhone, input “0000.”

The headset and the iPhone are paired with each other and connected. You hear voice guidance “BLUETOOTH connected”.

If they are not connected, see “[Connecting to a paired iPhone.](#)”

If [MDR-XB950N1] does not appear on the display, try again from step 3.

\* A Passkey may be called a “Passcode,” a “PIN code,” or a “Password.”

## Note

- If pairing is not established within about 5 minutes, pairing mode will be canceled and the headset will turn off. In this case, start over from step 1.
- Once BLUETOOTH devices are paired, there is no need to pair them again, except in the following cases:
  - Pairing information has been deleted after repair, etc.
  - The headset is already paired with 8 devices and another device is to be paired.  
The headset can be paired with up to 8 devices. If a new device is paired after 8 devices are already paired, the paired device with the oldest connection time is replaced by the new one.
  - When the pairing information for the headset has been deleted from the BLUETOOTH device.

When the headset is initialized, all pairing information is deleted.

In this case, delete the pairing information of the headset from the BLUETOOTH device, and then pair them again.

- If the pairing information was deleted by initializing the headset, etc., delete from your iPhone the pairing information for the headset, and then pair them again.
- The headset can be paired with multiple devices, but can only play music from one paired device at a time.

### Hint

- The above procedure is an example. For details, refer to the operating instructions supplied with your iPhone.
- To delete all pairing information, see "[Initializing the headset to restore factory settings.](#)"

---

### Related Topic

- [How to make a wireless connection to BLUETOOTH devices](#)
- [Connecting to a paired iPhone](#)
- [Listening to music from a device connected via BLUETOOTH](#)
- [Initializing the headset to restore factory settings](#)

Wireless Noise Canceling Stereo Headset  
MDR-XB950N1

## Connecting to a paired iPhone

---

1 Unlock the screen of the iPhone if it is locked.

2 Turn on the headset.

Press and hold the  button for about 2 seconds.

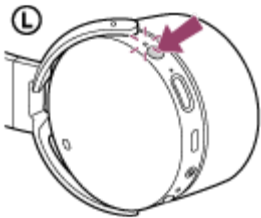

Make sure that the indicator (blue) flashes after you release the button. You hear voice guidance "Power on".

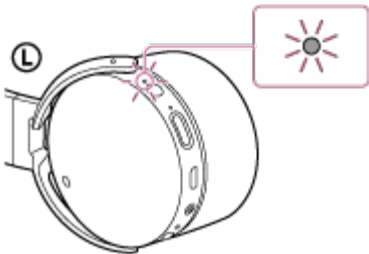

After the headset turns on, if it has automatically connected to the last connected device, you hear voice guidance "BLUETOOTH connected".

Check the connection status on the iPhone. If not connected, proceed to step 3.

3 Display the devices paired with the iPhone.

1. Select [Settings].
2. Touch [Bluetooth].



3. Touch [  ] to change it to [  ] (turn on the BLUETOOTH function).

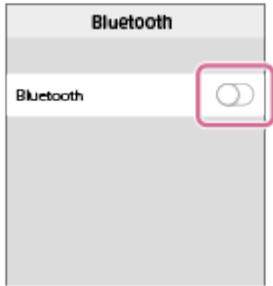

4 Touch [MDR-XB950N1].

You hear voice guidance “BLUETOOTH connected”.

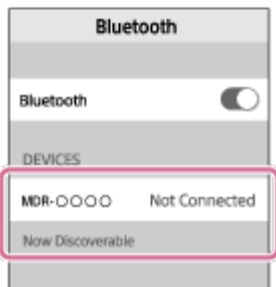

### Hint

- The above procedure is an example. For details, refer to the operating instructions supplied with your iPhone.
- If the iPhone was connected with the headset the last time, an HFP/HSP connection is made when you turn on the headset. While the headset is on, you can make an A2DP connection (music playback) by pressing the  button.

### Note

- If the last-connected BLUETOOTH device is put near the headset, the headset may connect automatically to the device by simply turning on the headset. In this case, deactivate the BLUETOOTH function on the BLUETOOTH device or turn off the power.
- If you cannot connect your BLUETOOTH device to the headset, deactivate pairing on your BLUETOOTH device and perform pairing again. For details, refer to the operating instructions supplied with your BLUETOOTH device.

---

## Related Topic

- [How to make a wireless connection to BLUETOOTH devices](#)
- [Pairing and connecting with an iPhone](#)
- [Listening to music from a device connected via BLUETOOTH](#)

Wireless Noise Canceling Stereo Headset  
MDR-XB950N1

## Pairing and connecting with a computer (Windows 10)

Pairing is the process required to create a link between BLUETOOTH devices to allow wireless connection. You must pair a device with the headset to be able to make a BLUETOOTH connection for the first time.

Before you start pairing operation, make sure that:

- Your computer has a BLUETOOTH function that supports music playback connections (A2DP).
- The computer is placed within 1 m(3 feet) of the headset.
- The headset is charged sufficiently.
- The operating instructions of the computer is on hand.
- Depending on the computer, the built-in BLUETOOTH adaptor should be turned on. For whether or not a BLUETOOTH adaptor is incorporate, and for how to turn it on, refer to the operating instructions supplied with the computer.

### 1 Enter pairing mode on this headset.

When you pair the headset with a device for the first time after you bought it, or after you initialized the headset (the headset has no pairing information), press and hold the  button for about 2 seconds when the headset is turned off. The headset enters pairing mode automatically.

When you pair a 2nd or subsequent device (the headset has pairing information for other devices), press and hold the  button for about 7 seconds.

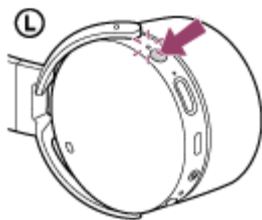

Make sure that the indicator flashes blue and red alternately after you release the button. You hear voice guidance "BLUETOOTH pairing".

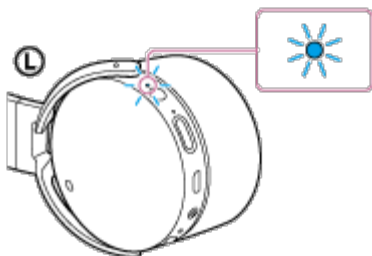

### 2 Resume the computer from sleep mode.

### 3 Register the headset using the computer.

1. Click the [Start] button, then [Settings].
2. Click [Devices].

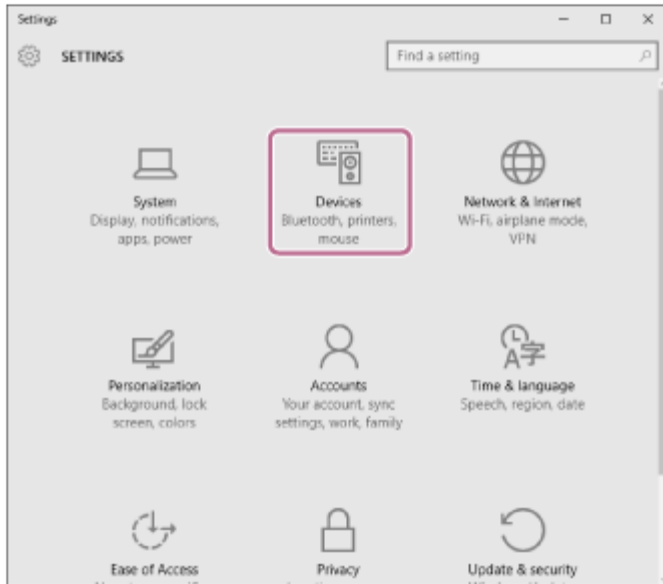

3. Click the [Bluetooth] tab, then click the [Bluetooth] button to turn on the BLUETOOTH function.

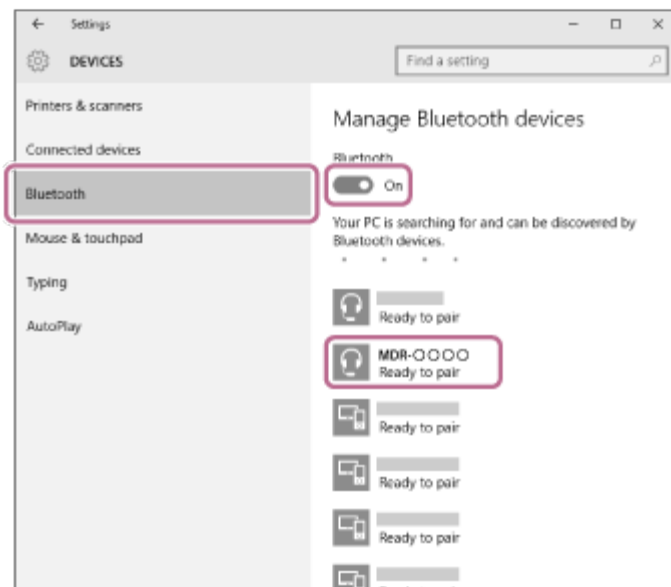

4. Select [MDR-XB950N1], then click [Pair].

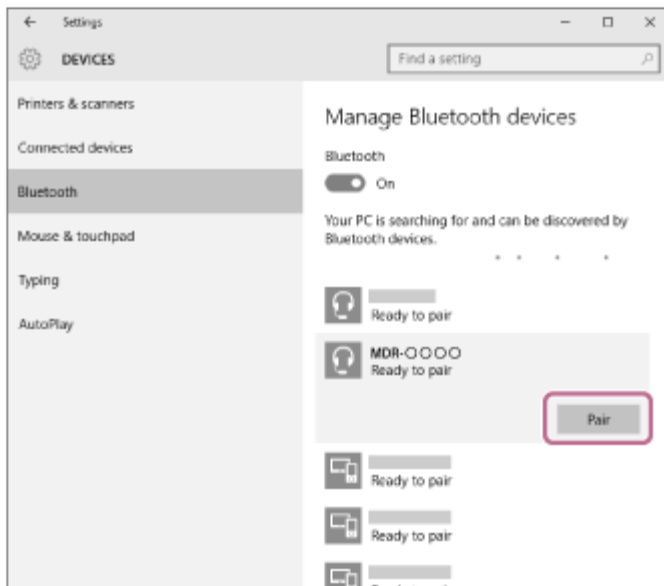

If passkey (\*) input is required on the display of the computer, input “0000.”

The headset and the computer are paired with each other and connected.

You hear voice guidance “BLUETOOTH connected”.

If they are not connected, refer to [“Connecting to a paired computer \(Windows 10\).”](#)

If [MDR-XB950N1] does not appear on the display, try again from step 3.

\* A Passkey may be called a “Passcode,” a “PIN code,” or a “Password.”

### Note

- If pairing is not established within about 5 minutes, pairing mode will be canceled and the headset will turn off. In this case, start over from step 1.
- Once BLUETOOTH devices are paired, there is no need to pair them again, except in the following cases:
  - Pairing information has been deleted after repair, etc.
  - The headset is already paired with 8 devices and another device is to be paired.  
The headset can be paired with up to 8 devices. If a new device is paired after 8 devices are already paired, the paired device with the oldest connection time is replaced by the new one.
  - When the pairing information for the headset has been deleted from the BLUETOOTH device.
  - When the headset is initialized, all pairing information is deleted.  
In this case, delete the pairing information of the headset from the BLUETOOTH device, and then pair them again.
- The headset can be paired with multiple devices, but can only play music from one paired device at a time.

### Hint

- The above procedure is an example. For details, refer to the operating instructions supplied with your computer.
- To delete all pairing information, refer to [“Initializing the headset to restore factory settings.”](#)

### Related Topic

- [How to make a wireless connection to BLUETOOTH devices](#)

- Connecting to a paired computer (Windows 10)
- Listening to music from a device connected via BLUETOOTH
- Disconnecting BLUETOOTH connection (after use)
- Initializing the headset to restore factory settings

Wireless Noise Canceling Stereo Headset  
MDR-XB950N1

## Pairing and connecting with a computer (Windows 8/Windows 8.1)

Pairing is the process required to create a link between BLUETOOTH devices to allow wireless connection. You must pair a device with the headset to be able to make a BLUETOOTH connection for the first time.

Before you start pairing operation, make sure that:

- Your computer has a BLUETOOTH function that supports music playback connections (A2DP).
- The computer is placed within 1 m(3 feet) of the headset.
- The headset is charged sufficiently.
- The operating instructions of the computer is on hand.
- Depending on the computer, the built-in BLUETOOTH adaptor should be turned on. For whether or not a BLUETOOTH adaptor is incorporate, and for how to turn it on, refer to the operating instructions supplied with the computer.

### 1 Enter pairing mode on this headset.

When you pair the headset with a device for the first time after you bought it, or after you initialized the headset (the headset has no pairing information), press and hold the  button for about 2 seconds when the headset is turned off. The headset enters pairing mode automatically.

When you pair a 2nd or subsequent device (the headset has pairing information for other devices), press and hold the  button for about 7 seconds.

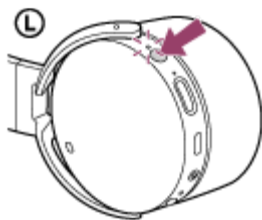

Make sure that the indicator flashes blue and red alternately after you release the button. You hear voice guidance "BLUETOOTH pairing".

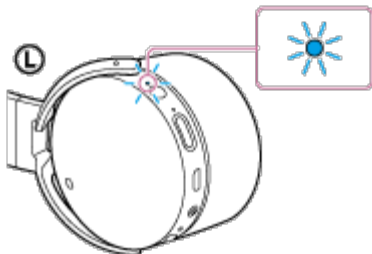

### 2 Resume the computer from sleep mode.

### 3 Register the headset using the computer.

1. Move the mouse pointer to the top-right corner of the screen (when using a touch panel, swipe from the right edge of the screen), then select [Settings] from the Charm Bar.



2. Select [Change PC settings] of the [Settings] charm.

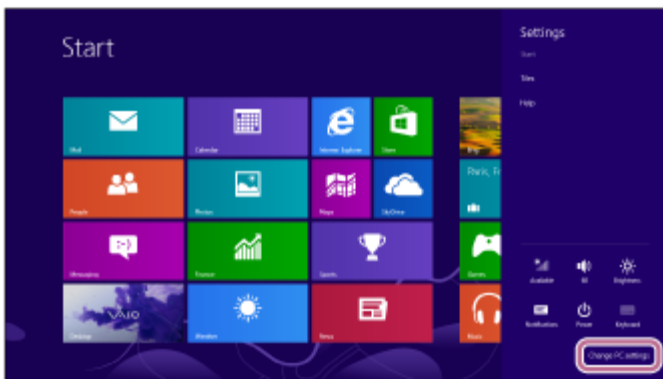

3. Select [Devices] of [PC settings].

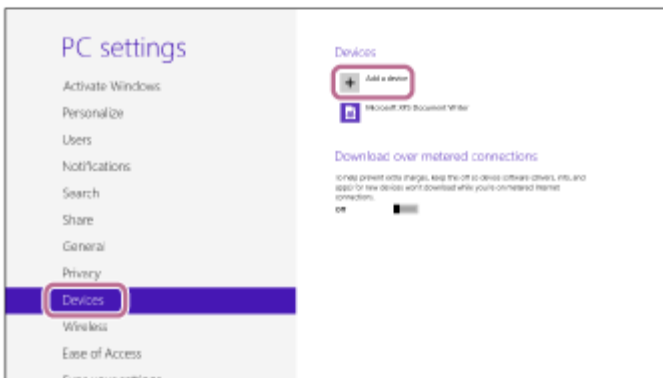

4. Select [Add a device].
5. Select [MDR-XB950N1].

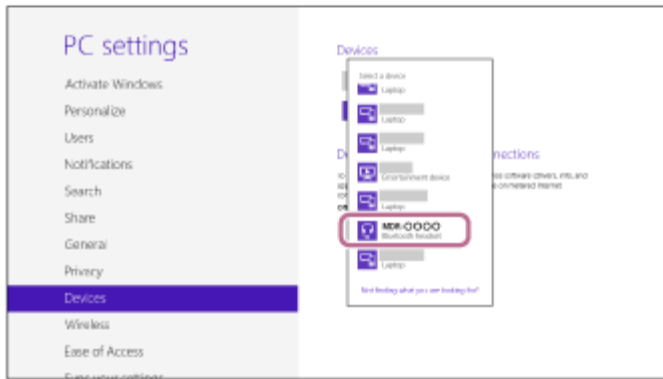

If passkey (\*) input is required on the display of the computer, input “0000.”

The headset and the computer are paired with each other and connected. You hear voice guidance “BLUETOOTH connected”.

If they are not connected, see “[Connecting to a paired computer \(Windows 8/Windows 8.1\)](#).”

If [MDR-XB950N1] does not appear on the display, try again from step 3.

\* A Passkey may be called a “Passcode,” a “PIN code,” or a “Password.”

## Note

- If pairing is not established within about 5 minutes, pairing mode will be canceled and the headset will turn off. In this case, start over from step 1.
- Once BLUETOOTH devices are paired, there is no need to pair them again, except in the following cases:
  - Pairing information has been deleted after repair, etc.
  - The headset is already paired with 8 devices and another device is to be paired.  
The headset can be paired with up to 8 devices. If a new device is paired after 8 devices are already paired, the paired device with the oldest connection time is replaced by the new one.
  - When the pairing information for the headset has been deleted from the BLUETOOTH device.
  - When the headset is initialized, all pairing information is deleted.  
In this case, delete the pairing information of the headset from the BLUETOOTH device, and then pair them again.
- The headset can be paired with multiple devices, but can only play music from one paired device at a time.

## Hint

- The above procedure is an example. For details, refer to the operating instructions supplied with your computer.
- To delete all pairing information, see “[Initializing the headset to restore factory settings](#).”

## Related Topic

- [How to make a wireless connection to BLUETOOTH devices](#)
- [Connecting to a paired computer \(Windows 8/Windows 8.1\)](#)
- [Listening to music from a device connected via BLUETOOTH](#)
- [Disconnecting BLUETOOTH connection \(after use\)](#)
- [Initializing the headset to restore factory settings](#)

Wireless Noise Canceling Stereo Headset  
MDR-XB950N1

## Pairing and connecting with a computer (Windows 7)

Pairing is the process required to create a link between BLUETOOTH devices to allow wireless connection. You must pair a device with the headset to be able to make a BLUETOOTH connection for the first time.

Before you start pairing operation, make sure that:

- Your computer has a BLUETOOTH function that supports music playback connections (A2DP).
- The computer is placed within 1 m(3 feet) of the headset.
- The headset is charged sufficiently.
- The operating instructions of the computer is on hand.
- Depending on the computer, the built-in BLUETOOTH adaptor should be turned on. For whether or not a BLUETOOTH adaptor is incorporate, and for how to turn it on, refer to the operating instructions supplied with the computer.

### 1 Enter pairing mode on this headset.

When you pair the headset with a device for the first time after you bought it, or after you initialized the headset (the headset has no pairing information), press and hold the  button for about 2 seconds when the headset is turned off. The headset enters pairing mode automatically.

When you pair a 2nd or subsequent device (the headset has pairing information for other devices), press and hold the  button for about 7 seconds.

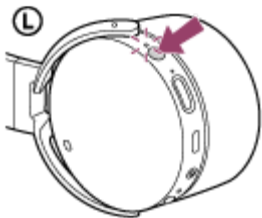

Make sure that the indicator flashes blue and red alternately after you release the button. You hear voice guidance "BLUETOOTH pairing".

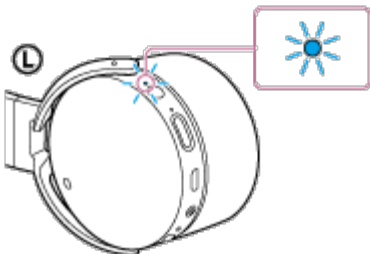

### 2 Resume the computer from sleep mode.

### 3 Search for the headset using the computer.

1. Click the [Start] button, then [Devices and Printers].
2. Click [Add a device].

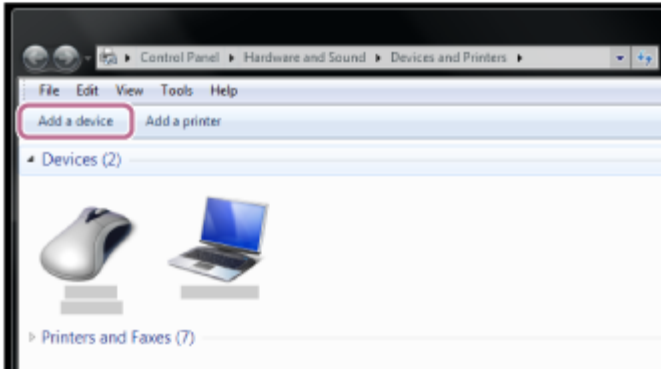

3. Select [MDR-XB950N1], then click [Next].

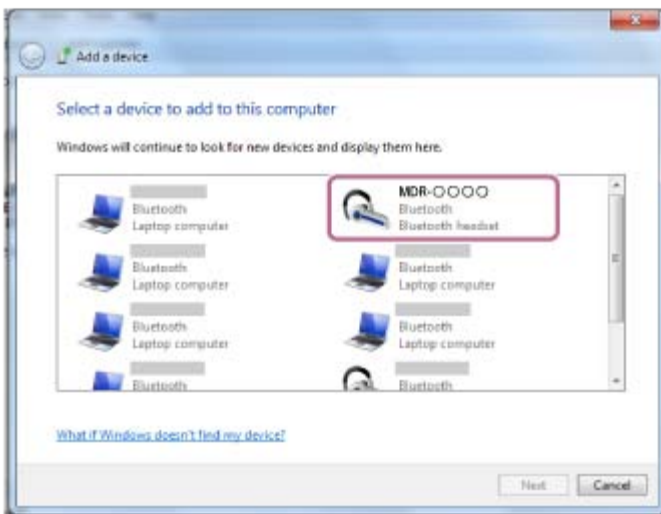

If passkey (\*) input is required on the display of the computer, input "0000."

The headset and the computer are paired with each other and connected. You hear voice guidance "BLUETOOTH connected".

If they are not connected, see "[Connecting to a paired computer \(Windows 7\).](#)"

If [MDR-XB950N1] does not appear on the display, try again from step 3.

\* A Passkey may be called a "Passcode," a "PIN code," or a "Password."

## Note

- If pairing is not established within about 5 minutes, pairing mode will be canceled and the headset will turn off. In this case, start over from step 1.
- Once BLUETOOTH devices are paired, there is no need to pair them again, except in the following cases:
  - Pairing information has been deleted after repair, etc.
  - The headset is already paired with 8 devices and another device is to be paired.  
The headset can be paired with up to 8 devices. If a new device is paired after 8 devices are already paired, the paired device with the oldest connection time is replaced by the new one.
  - When the pairing information for the headset has been deleted from the BLUETOOTH device.
  - When the headset is initialized, all pairing information is deleted.  
In this case, delete the pairing information of the headset from the BLUETOOTH device, and then pair them again.

- The headset can be paired with multiple devices, but can only play music from one paired device at a time.

## Hint

- The above procedure is an example. For details, refer to the operating instructions supplied with your computer.
- To delete all pairing information, see [“Initializing the headset to restore factory settings.”](#)

---

## Related Topic

- [How to make a wireless connection to BLUETOOTH devices](#)
- [Connecting to a paired computer \(Windows 7\)](#)
- [Listening to music from a device connected via BLUETOOTH](#)
- [Disconnecting BLUETOOTH connection \(after use\)](#)
- [Initializing the headset to restore factory settings](#)

Wireless Noise Canceling Stereo Headset  
MDR-XB950N1

## Connecting to a paired computer (Windows 10)

---

Before starting the operation, make sure the following:

- Depending on the computer, the built-in BLUETOOTH adaptor should be turned on. For whether or not a BLUETOOTH adaptor is incorporate, and for how to turn it on, refer to the operating instructions supplied with the computer.

1 Resume the computer from sleep mode.

2 Turn on the headset.

Press and hold the  button for about 2 seconds.

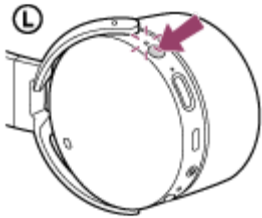

Make sure that the indicator (blue) flashes after you release the button. You hear voice guidance "Power on".

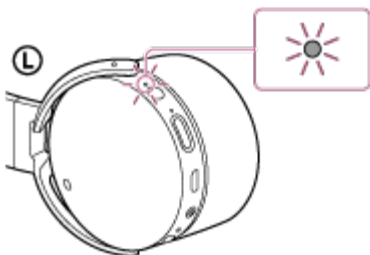

After the headset turns on, if it has automatically connected to the last connected device, you hear voice guidance "BLUETOOTH connected".

Use the computer to check whether the connection is established, and if it is not established, proceed to step 3.

If the computer has connected to the last BLUETOOTH device connected, disconnect it, then proceed to the next step.

3 Select the headset using the computer.

1. Right-click the volume icon on the windows toolbar, then click [Playback devices].

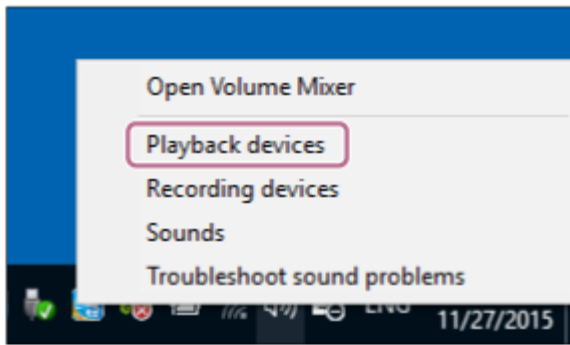

2. Right-click [MDR-XB950N1].

If [MDR-XB950N1] is not displayed, right-click on the [Sound] screen, then select [Show Disabled Devices].

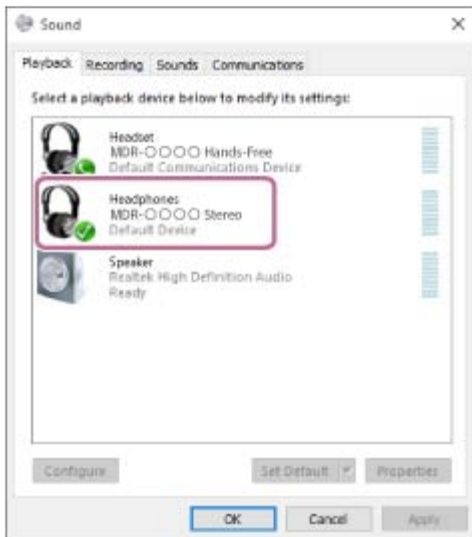

3. Click [Connect].

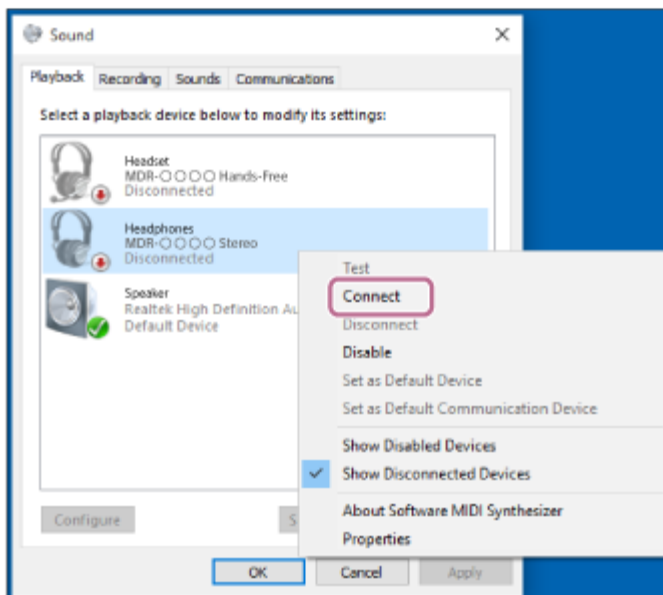

The connection is established.

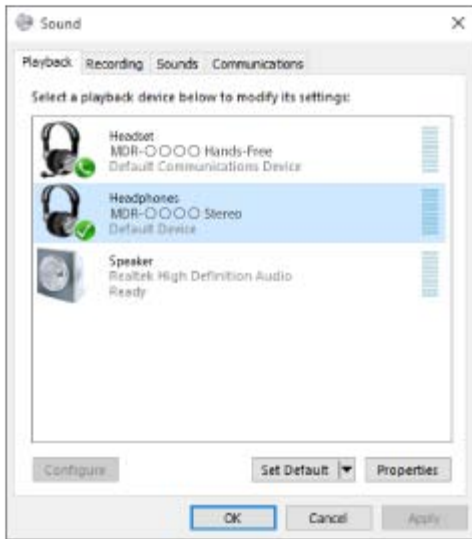

## Hint

- The above procedure is an example. For details, refer to the operating instructions supplied with your computer.
- If the computer was connected with the headset the last time, an HFP/HSP connection is made when you turn on the headset. While the headset is on, you can make an A2DP connection (music playback) by pressing the ►|| button.

## Note

- If the last-connected BLUETOOTH device is put near the headset, the headset may connect automatically to the device by simply turning on the headset. In this case, deactivate the BLUETOOTH function on the BLUETOOTH device or turn off the power.
- If you cannot connect your BLUETOOTH device to the headset, deactivate pairing on your BLUETOOTH device and perform pairing again. For details, refer to the operating instructions supplied with your BLUETOOTH device.

## Related Topic

- [How to make a wireless connection to BLUETOOTH devices](#)
- [Pairing and connecting with a computer \(Windows 10\)](#)
- [Listening to music from a device connected via BLUETOOTH](#)
- [Disconnecting BLUETOOTH connection \(after use\)](#)

Wireless Noise Canceling Stereo Headset  
MDR-XB950N1

## Connecting to a paired computer (Windows 8/Windows 8.1)

---

Before starting the operation, make sure the following:

- Depending on the computer, the built-in BLUETOOTH adaptor should be turned on. For whether or not a BLUETOOTH adaptor is incorporate, and for how to turn it on, refer to the operating instructions supplied with the computer.

1 Resume the computer from sleep mode.

2 Turn on the headset.

Press and hold the  button for about 2 seconds.

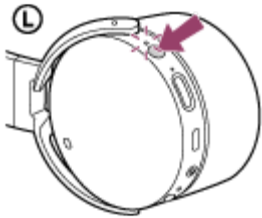

Make sure that the indicator (blue) flashes after you release the button. You hear voice guidance "Power on".

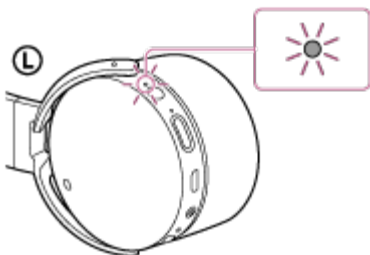

After the headset turns on, if it has automatically connected to the last connected device, you hear voice guidance "BLUETOOTH connected".

Use the computer to check whether the connection is established, and if it is not established, proceed to step 3.

If the computer has connected to the last BLUETOOTH device connected, disconnect it, then proceed to the next step.

3 Select the headset using the computer.

1. Select [Desktop] on the Start screen.
2. Move the mouse pointer to the top-right corner of the screen (when using a touch panel, swipe from the right edge of the screen), then select [Settings] from the Charm Bar.



3. Select [Control Panel] in the [Settings] charm.
4. Select [Hardware and Sound], then [Devices and Printers].

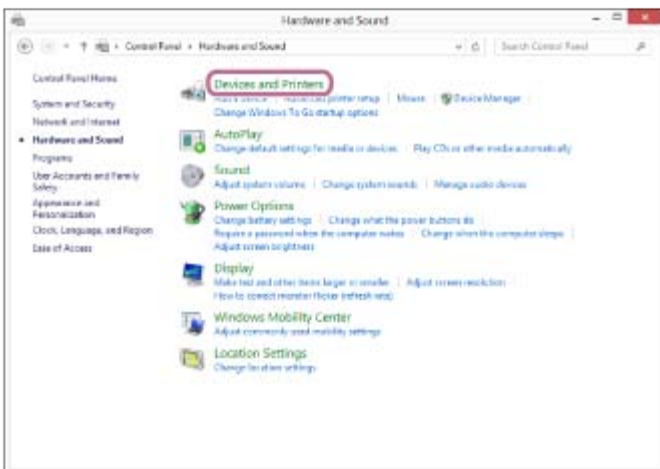
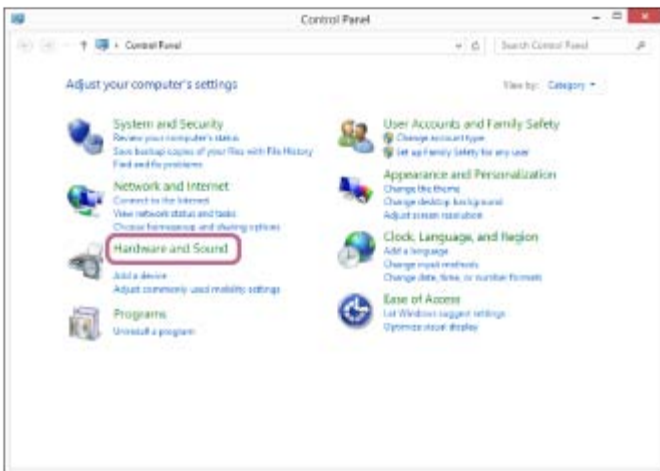

5. Right-click [MDR-XB950N1] in the [Devices and Printers] screen.

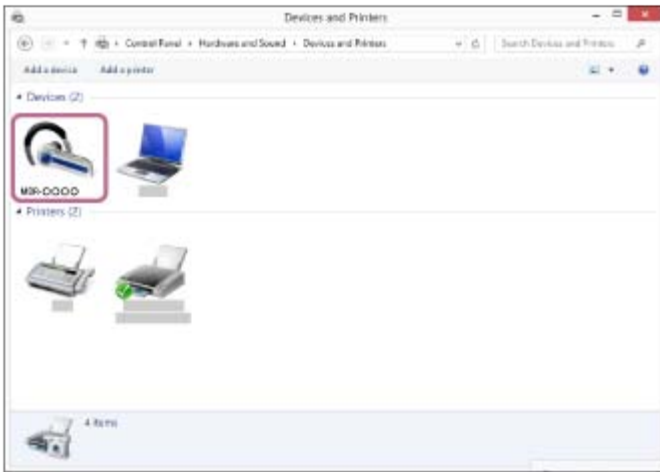

6. Select [Advanced Operation] — [Connect to audio sink device].



## Hint

- The above procedure is an example. For details, refer to the operating instructions supplied with your computer.
- If the computer was connected with the headset the last time, an HFP/HSP connection is made when you turn on the headset. While the headset is on, you can make an A2DP connection (music playback) by pressing the ►|| button.

## Note

- If the last-connected BLUETOOTH device is put near the headset, the headset may connect automatically to the device by simply turning on the headset. In this case, deactivate the BLUETOOTH function on the BLUETOOTH device or turn off the power.
- If you cannot connect your BLUETOOTH device to the headset, deactivate pairing on your BLUETOOTH device and perform pairing again. For details, refer to the operating instructions supplied with your BLUETOOTH device.

## Related Topic

- [How to make a wireless connection to BLUETOOTH devices](#)
- [Pairing and connecting with a computer \(Windows 8/Windows 8.1\)](#)

- Listening to music from a device connected via BLUETOOTH
- Disconnecting BLUETOOTH connection (after use)

4-692-591-11(1) Copyright 2017 Sony Corporation

Wireless Noise Canceling Stereo Headset  
MDR-XB950N1

## Connecting to a paired computer (Windows 7)

---

Before starting the operation, make sure the following:

- Depending on the computer, the built-in BLUETOOTH adaptor should be turned on. For whether or not a BLUETOOTH adaptor is incorporate, and for how to turn it on, refer to the operating instructions supplied with the computer.

1 Resume the computer from sleep mode.

2 Turn on the headset.

Press and hold the  button for about 2 seconds.

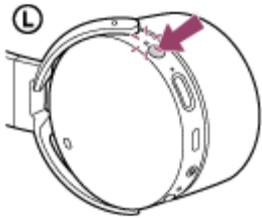

Make sure that the indicator (blue) flashes after you release the button. You hear voice guidance "Power on".

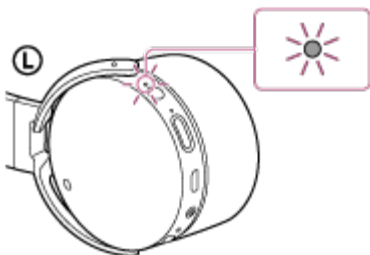

After the headset turns on, if it has automatically connected to the last connected device, you hear voice guidance "BLUETOOTH connected".

Use the computer to check whether the connection is established, and if it is not established, proceed to step 3.

If the computer has connected to the last BLUETOOTH device connected, disconnect it, then proceed to the next step.

3 Select the headset using the computer.

1. Click the [Start] button, then [Devices and Printers].
2. Double-click [MDR-XB950N1] of the device.



3. Click [Listen to Music].

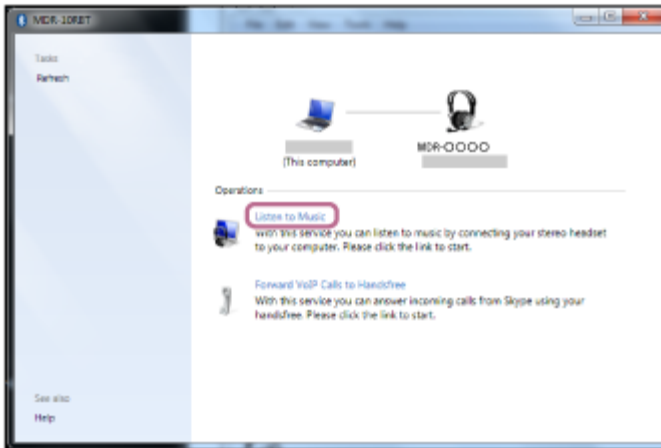

## Hint

- The above procedure is an example. For details, refer to the operating instructions supplied with your computer.
- If the computer was connected with the headset the last time, an HFP/HSP connection is made when you turn on the headset. While the headset is on, you can make an A2DP connection (music playback) by pressing the ►|| button.

## Note

- If the last-connected BLUETOOTH device is put near the headset, the headset may connect automatically to the device by simply turning on the headset. In this case, deactivate the BLUETOOTH function on the BLUETOOTH device or turn off the power.
- If you cannot connect your BLUETOOTH device to the headset, deactivate pairing on your BLUETOOTH device and perform pairing again. For details, refer to the operating instructions supplied with your BLUETOOTH device.

## Related Topic

- [How to make a wireless connection to BLUETOOTH devices](#)
- [Pairing and connecting with a computer \(Windows 7\)](#)
- [Listening to music from a device connected via BLUETOOTH](#)
- [Disconnecting BLUETOOTH connection \(after use\)](#)

Wireless Noise Canceling Stereo Headset  
MDR-XB950N1

## Pairing and connecting with other BLUETOOTH devices

Pairing is the process required to create a link between BLUETOOTH devices to allow wireless connection. You must pair a device with the headset to be able to make a BLUETOOTH connection for the first time. Before you start pairing operation, make sure that:

- The BLUETOOTH device is placed within 1 m(3 feet) of the headset.
- The headset is charged sufficiently.
- The operating instructions of the BLUETOOTH device is on hand.

### 1 Enter pairing mode on this headset.

When you pair the headset with a device for the first time after you bought it, or after you initialized the headset (the headset has no pairing information), press and hold the  button for about 2 seconds when the headset is turned off. The headset enters pairing mode automatically.

When you pair a 2nd or subsequent device (the headset has pairing information for other devices), press and hold the  button for about 7 seconds.

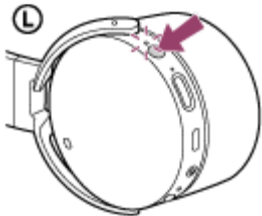

Make sure that the indicator flashes blue and red alternately after you release the button. You hear voice guidance "BLUETOOTH pairing".

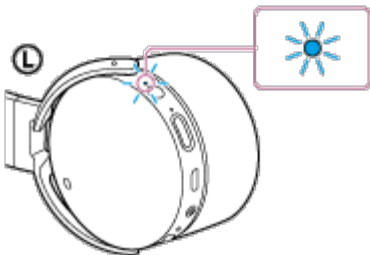

### 2 Perform the pairing procedure on the BLUETOOTH device to search for this headset.

[MDR-XB950N1] will be displayed on the list of detected devices on the screen of the BLUETOOTH device. If not displayed, repeat from step 1.

### 3 Select [MDR-XB950N1].

If passkey (\*) input is required on the display of the BLUETOOTH device, input “0000.”

\* A Passkey may be called a “Passcode,” a “PIN code,” or a “Password.”

#### 4 Make the BLUETOOTH connection from the BLUETOOTH device.

Depending on the BLUETOOTH device, the headset may be connected with the device automatically as soon as they are paired.

When connected, you hear voice guidance “BLUETOOTH connected”.

#### Note

- If pairing is not established within about 5 minutes, pairing mode will be canceled and the headset will turn off. In this case, start over from step 1.
- When pairing with a BLUETOOTH device that cannot display a list of detected devices or that has no display, you may pair the device by setting both the headset and the BLUETOOTH device to pairing mode. At this time, if passkey is set other than “0000” on the BLUETOOTH device, pairing cannot be done with the headset.
- Once BLUETOOTH devices are paired, there is no need to pair them again, except in the following cases:
  - Pairing information has been deleted after repair, etc.
  - The headset is already paired with 8 devices and another device is to be paired.  
The headset can be paired with up to 8 devices. If a new device is paired after 8 devices are already paired, the paired device with the oldest connection time is replaced by the new one.
  - When the pairing information for the headset has been deleted from the BLUETOOTH device.
  - When the headset is initialized, all pairing information is deleted.  
In this case, delete the pairing information of the headset from the BLUETOOTH device, and then pair them again.
- The headset can be paired with multiple devices, but can only play music from one paired device at a time.

#### Hint

- The above procedure is an example. For details, refer to the operating instructions supplied with your BLUETOOTH device.
- To delete all pairing information, see “[Initializing the headset to restore factory settings.](#)”

#### Related Topic

- [How to make a wireless connection to BLUETOOTH devices](#)
- [Connecting to a paired BLUETOOTH device](#)
- [Listening to music from a device connected via BLUETOOTH](#)
- [Initializing the headset to restore factory settings](#)

Wireless Noise Canceling Stereo Headset  
MDR-XB950N1

## Connecting to a paired BLUETOOTH device

---

### 1 Turn on the headset.

Press and hold the  button for about 2 seconds.

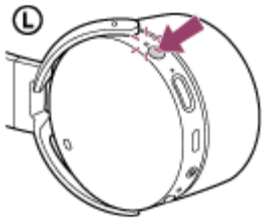

Make sure that the indicator (blue) flashes after you release the button. You hear voice guidance “Power on”.

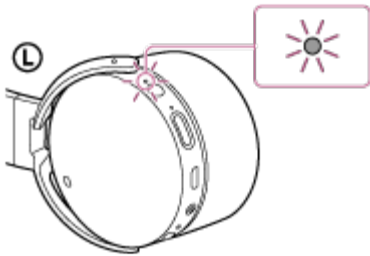

After the headset turns on, if it has automatically connected to the last connected device, you hear voice guidance “BLUETOOTH connected”.

Check the connection status on the BLUETOOTH device. If not connected, proceed to step 2.

### 2 Make the BLUETOOTH connection from the BLUETOOTH device.

For details, refer to the operating instructions supplied with your BLUETOOTH device.  
When connected, you hear voice guidance “BLUETOOTH connected”.

#### Hint

- The above procedure is an example. For details, refer to the operating instructions supplied with your BLUETOOTH device.
- If the BLUETOOTH device was connected with the headset the last time, an HFP/HSP connection is made when you turn on the headset. While the headset is on, you can make an A2DP connection (music playback) by pressing the  button.

## Note

- If the last-connected BLUETOOTH device is put near the headset, the headset may connect automatically to the device by simply turning on the headset. In this case, deactivate the BLUETOOTH function on the BLUETOOTH device or turn off the power.
- If you cannot connect your BLUETOOTH device to the headset, deactivate pairing on your BLUETOOTH device and perform pairing again. For details, refer to the operating instructions supplied with your BLUETOOTH device.

---

## Related Topic

- [How to make a wireless connection to BLUETOOTH devices](#)
- [Pairing and connecting with other BLUETOOTH devices](#)
- [Listening to music from a device connected via BLUETOOTH](#)

Wireless Noise Canceling Stereo Headset  
MDR-XB950N1

## Connecting the headset to both a music player and a smartphone or mobile phone

---

To use a BLUETOOTH music player for listening to music and a BLUETOOTH smartphone for making phone calls, the headset needs to be connected with each device with a BLUETOOTH connection.

- 1 Pair the headset with BLUETOOTH devices, respectively.
- 2 Make an A2DP BLUETOOTH connection between the headset and the BLUETOOTH music player.
- 3 Make an HFP or HSP BLUETOOTH connection between the headset and the BLUETOOTH smartphone or mobile phone.

### Note

- If the smartphone or mobile phone was connected with the headset the last time, an HFP or HSP connection is made automatically when you turn on the headset. At the same time, an A2DP connection may also be made automatically. If this happens, disconnect the headset from the smartphone or mobile phone once using the phone, then connect the devices again by repeating the process from step 2.

Wireless Noise Canceling Stereo Headset  
MDR-XB950N1

## Connecting the headset to 2 Android smartphones

When you connect the headset to a smartphone, usually the music playback function and the phone call function are both connected automatically.

To make a multi point connection with 2 smartphones separately, one for listening to music and the other for making phone calls, change the settings of the smartphones so that only one of the functions is connected for each smartphone.

- 1 Pair the headset with both smartphones, respectively.
- 2 Use one of the smartphones to establish a BLUETOOTH connection with the headset.
- 3 On the smartphone connected to the headset, uncheck either [Phone audio] (HFP) or [Media audio] (A2DP).

Example: To connect "Media audio" (A2DP) only

Touch [Settings] - [Bluetooth] - the setting icon next to [MDR-XB950N1].

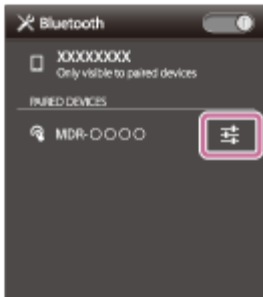

On the [Paired Bluetooth device] screen, uncheck [Phone audio].

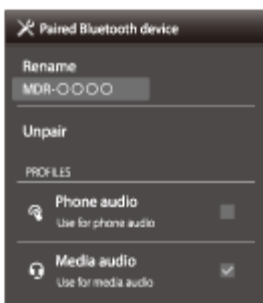

- 4 Terminate the BLUETOOTH connection of the smartphone.

---

5 Use the other smartphone to establish a BLUETOOTH connection to the headset.

6 In the same way, uncheck the function that you did not uncheck in step 3.

7 Use the first smartphone to establish a BLUETOOTH connection again.

Both smartphones are connected to the headset with only one function enabled.

#### Hint

- The above procedure is an example. For details, refer to the operating instructions supplied with your Android smartphones.

Wireless Noise Canceling Stereo Headset  
MDR-XB950N1

## Connecting the headset to an Android smartphone and an iPhone

---

When you connect the headset to a smartphone, usually the music playback function and the phone call function are both connected automatically. To make a multi point connection using an Android smartphone and an iPhone separately for listening to music and making phone calls, change the settings on the Android smartphone so that only one of the functions is connected. Connect the Android smartphone first, and then connect the iPhone.

You cannot set the iPhone to connect one function only.

- 1 Pair the headset with both Android smartphone and iPhone, respectively.
- 2 Use the Android smartphone to establish a BLUETOOTH connection with the headset.
- 3 On the Android smartphone connected to the headset, uncheck either [Phone audio] (HFP) or [Media audio] (A2DP).

Example: To connect "Media audio" (A2DP) only

Touch [Settings] - [Bluetooth] - the setting icon next to [MDR-XB950N1].



On the [Paired Bluetooth device] screen, uncheck [Phone audio].

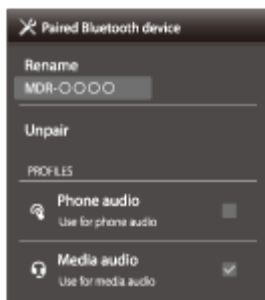

**4** Use the iPhone to establish a BLUETOOTH connection to the headset.

The iPhone is connected to the headset with both functions, but you can only use the function that you unchecked in step 3.

**Hint**

- The above procedure is an example. For details, refer to the operating instructions supplied with your Android smartphone.

**Note**

- If you connect an Android smartphone with [Phone audio] (HFP), the remaining battery charge of the headset will not be displayed correctly on an iPhone.

Wireless Noise Canceling Stereo Headset  
MDR-XB950N1

## Using the supplied headphone cable

You can use the headset as noise canceling headphones by connecting a device via the supplied headphone cable and turning the headset on. When the headset is powered on, you can also use the bass effect function. When turning on the headset, the NC (noise canceling) indicator (green) lights up or flashes.

- 1 Connect a playback device to the INPUT jack with the supplied headphone cable.

Make sure you connect the L-shaped plug to the playback device.

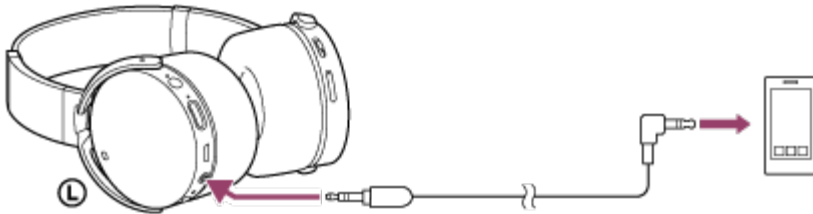

### Note

- Use the supplied headphone cable only.
- Make sure you insert the plug firmly.
- The BLUETOOTH function cannot be used.
- The jog switch ( / / / / ) and +/- buttons cannot be used. For volume, play/pause and other operations, control with the connected device.
- The NC and BASS EFFECT buttons cannot be used when the headset is powered off.

### Hint

- When the headset is turned off, you can use it as ordinary headphones. The headset can be charged while in use.
- When the noise canceling function is turned on, the headset turns off automatically if you disconnect the headphone cable.
- When an incoming call arrives, a ring tone will be heard via the headphones. Answer the call using your smartphone or mobile phone, and talk using the microphone of the phone. You can hear the voice of the caller from the headphones.
- If you disconnect the headphone cable from the smartphone or mobile phone, you can talk using the microphone and speaker of the phone.

Wireless Noise Canceling Stereo Headset  
MDR-XB950N1

## Listening to music from a device connected via BLUETOOTH

You can enjoy listening to music and basic remote control operation of a BLUETOOTH device via a BLUETOOTH connection. The BLUETOOTH device is required to support the following BLUETOOTH profiles.

- A2DP (Advanced Audio Distribution Profile):  
enables you to enjoy high-quality audio content wirelessly.
- AVRCP (Audio Video Remote Control Profile):  
enables you to adjust volume, etc.

The operation may vary depending on the BLUETOOTH device. Refer to the operating instructions supplied with your BLUETOOTH device.

1 Connect the headset to a BLUETOOTH device.

2 Wear the headset.

Adjust the length of the headband.

Put the headset with **L** indication on your left ear and **R** indication on your right ear. The **L** unit of the headset has a tactile dot.

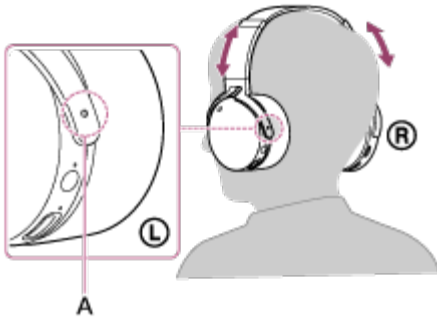

A: Tactile dot

3 Play back music or video on the BLUETOOTH device.

Adjust the volume on the BLUETOOTH device.

4 Adjust the volume by pressing the +/- buttons of the headset.

When the volume reaches the maximum or minimum, an alarm sounds.

## Note

- If the communication condition is poor, the BLUETOOTH device may react incorrectly to the operation on the headset.

## Hint

- The headset supports SCMS-T content protection. You can enjoy music, etc., from a device such as a mobile phone or portable TV that supports SCMS-T content protection.
- Depending on the BLUETOOTH device, it may be necessary to adjust the volume or set the audio output setting on the BLUETOOTH device.
- Volume during a call and volume during music playback can be adjusted independently. Changing the call volume does not change the volume of music playback, and vice versa.

---

## Related Topic

- [How to make a wireless connection to BLUETOOTH devices](#)
- [Controlling the audio device \(BLUETOOTH connection\)](#)
- [Using the noise canceling function](#)
- [About the Automatic AI noise canceling function](#)
- [Switching the sound quality mode](#)

Wireless Noise Canceling Stereo Headset  
MDR-XB950N1

## Controlling the audio device (BLUETOOTH connection)

If the BLUETOOTH device supports AVRCP, you can control it by the headset. The functions available may vary depending on the BLUETOOTH device. Refer to the operating instructions supplied with your BLUETOOTH device.

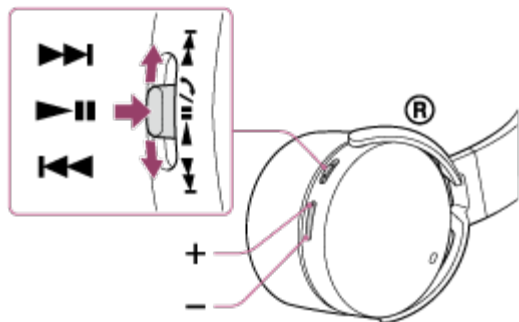

Each button has the following function:

▶||:

- Press once during pause to start playback.
- Press once during playback to pause.

◀◀/▶▶:

- Slide once to skip to the beginning of the next track/beginning of the previous (or current) track.
- Slide and hold to fast-reverse/fast-forward.

+/-:

- Press the + or - button to adjust the volume.

When connecting iOS devices such as iPhone, ▶|| has the following function:

- Press twice to skip to the beginning of the next track (●●).
- Press three times to skip to the beginning of the previous (or current) track (●●●).
- Press once and release, and then press and hold to fast-forward (● [bar]).
- Press twice and release, and then press and hold to fast-reverse (●● [bar]).

### Note

- If the communication condition is poor, the BLUETOOTH device may react incorrectly to the operation on the headset.
- The available functions may vary depending on the BLUETOOTH device. When you operate as illustrated above, it may operate differently or may not work at all.

Wireless Noise Canceling Stereo Headset  
MDR-XB950N1

## Disconnecting BLUETOOTH connection (after use)

---

- 1 If using a device that supports one-touch connection (NFC), touch the device to the headset again. (Unlock the screen of the device if it is locked.) If using a device that does not support one-touch connection (NFC), operate from the BLUETOOTH device.

When disconnected, you hear voice guidance "BLUETOOTH disconnected".

- 2 Press and hold the  button on the headset for about 2 seconds to turn off the headset.  
You hear voice guidance "Power off".

### Hint

- When you finish playing music, the BLUETOOTH connection may terminate automatically, depending on the BLUETOOTH device.

Wireless Noise Canceling Stereo Headset  
MDR-XB950N1

## What is noise canceling?

---

The noise canceling circuit actually senses outside noise with built-in microphones and sends an equal-but-opposite canceling signal to the headset.

### Note

- The noise canceling effect may not be pronounced in a very quiet environment, or some noise may be heard.
- Depending on how you wear the unit, the noise canceling effect may vary or a beeping sound (howling) may occur. In these cases, take off the unit and put it on again.
- The noise canceling function works for noise in the low frequency band primarily. Although noise is reduced, it is not canceled completely.
- When you use the unit in a train or a car, noise may occur depending on street conditions.
- Mobile phones may cause interference and noise. Should this occur, locate the unit further away from the mobile phone.
- Do not cover the microphones of the unit with your hands. The noise canceling function may not work properly, or a beeping sound (howling) may occur. In these cases, take your hands off of the microphones of the unit.

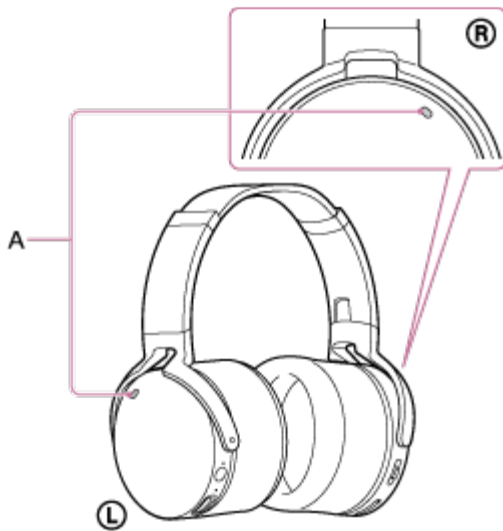

A: Microphones

---

### Related Topic

- [Using the noise canceling function](#)
- [About the Automatic AI noise canceling function](#)

Wireless Noise Canceling Stereo Headset  
MDR-XB950N1

## Using the noise canceling function

If you use the noise canceling function, you can enjoy music without being disturbed by ambient noise.

- 1 Press and hold the  button for about 2 seconds when the headset is turned off to turn on the headset.

You hear voice guidance “Power on”.

The noise canceling function is turned on automatically when you turn on the headset.

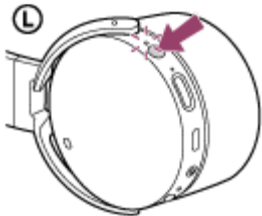

When the noise canceling function is turned on, the NC indicator (green) lights up.

## To turn off the noise canceling function

- Press the NC button. The NC indicator (green) flashes. You hear voice guidance “Noise canceling off”. (To turn on the function, press the NC button again. You hear voice guidance “Noise canceling on”.)

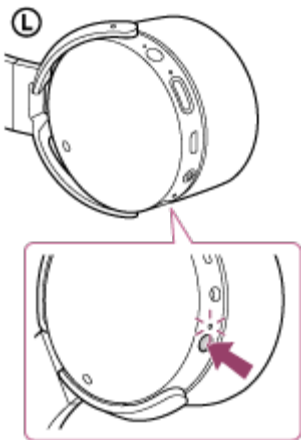

### Hint

- If you use the noise canceling function with a BLUETOOTH connection, the noise canceling function is on even if you connect the supplied headphone cable.
- You can also turn on/off the noise canceling function with the “Sony | Headphones Connect” app.

---

## Related Topic

- [What is noise canceling?](#)
- [About the Automatic AI noise canceling function](#)
- [What you can do with "Sony | Headphones Connect" app](#)

Wireless Noise Canceling Stereo Headset  
MDR-XB950N1

## About the Automatic AI noise canceling function

---

The Automatic AI (Artificial Intelligence) Noise Canceling function constantly analyzes environmental ambient sound components and automatically selects the most effective noise canceling mode.

### Noise canceling mode types

#### NC Mode A

Noise mainly in an airplane is effectively reduced.

#### NC Mode B

Noise mainly in a bus or a train is effectively reduced.

#### NC Mode C

Noise mainly found in an office environment (PC, copier, air ventilation, etc.) is effectively reduced.

---

### Related Topic

- [What is noise canceling?](#)
- [Using the noise canceling function](#)

Wireless Noise Canceling Stereo Headset  
MDR-XB950N1

## About the bass effect function

---

The bass effect function enhances low frequencies. You can turn on or off the bass effect function simply by pressing a button.

---

### Related Topic

- [Using the bass effect function](#)

Wireless Noise Canceling Stereo Headset  
MDR-XB950N1

## Using the bass effect function

---

You can enhance low frequencies thanks to the bass effect function.

- 1 When the headset is on, press the BASS EFFECT button.

The BASS EFFECT indicator (orange) lights up. You hear voice guidance “Bass effect on”.

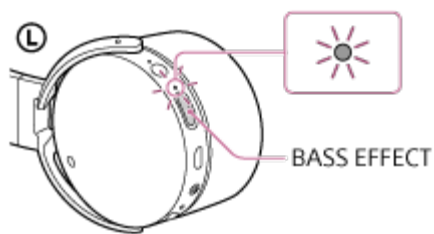

### To turn off the bass effect function

Press the BASS EFFECT button again. The BASS EFFECT indicator (orange) turns off. You hear voice guidance “Bass effect off.”

#### Note

- Since the function amplifies certain low frequencies, the effect may not be obtained with music that does not contain the frequencies to be amplified.
- The on or off status of the bass effect function remains and will be the same when you turn on the headset next time.

#### Hint

- You can set details of the sound effect for the bass effect function with the “Sony | Headphones Connect” app.

---

#### Related Topic

- [About the bass effect function](#)
- [What you can do with "Sony | Headphones Connect" app](#)

Wireless Noise Canceling Stereo Headset  
MDR-XB950N1

## Switching the sound quality mode

The sound quality is set to the “Priority on sound quality” mode as the default setting.

- When using an SBC, AAC, or aptX compatible device, use with the “Priority on sound quality” mode.
- If the connection is unstable, such as when producing only intermittent sound, select the “Priority on stable connection” mode.

### Sound quality and indicator (blue) of each mode

When you switch the sound quality mode, the indicator flashes in blue to show the current sound quality mode.

“Priority on sound quality” mode: 3 times ● - - ● - - ●  
SBC, AAC, or aptX is selected automatically.

“Priority on stable connection” mode: 1 time ●  
SBC

- 1 Turn on the headset by pressing the  button for more than 2 seconds while holding the + or - button down.

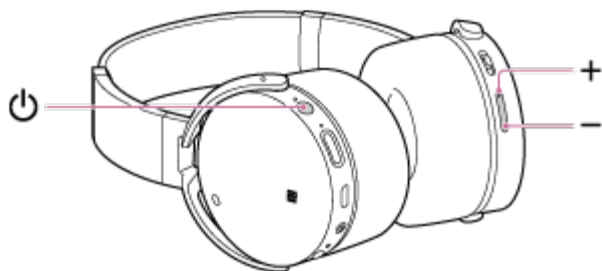

- To select “Priority on stable connection,” turn on the headset while holding the - button down.
- To select “Priority on sound quality,” turn on the headset while holding the + button down.

### To check the sound quality mode

While the headset is powered on, press and hold the  button, then press the + or - button within 2 seconds (before the power is turned off). The indicator will flash in blue 3 times (“Priority on sound quality” mode) or 1 time (“Priority on stable connection” mode).

#### Note

- When you turn on the headset by pressing the  button only, the indicator (blue) flashes two times to indicate the power-on, but the headset does not indicate the sound quality mode with flashes of the indicator (blue).



- The playback time may become shorter, depending on the sound quality and the conditions under which you are using the headset.
- Depending on the ambient conditions in the area where you are using the headset, intermittent sound may still occur, even if the “Priority on stable connection” mode is selected.

Wireless Noise Canceling Stereo Headset  
MDR-XB950N1

## Checking the sound quality mode

---

When you switch the sound quality mode, the indicator flashes in blue to show the current sound quality mode. When the headset is powered on, press and hold the  button, then press the + or - button within 2 seconds (before the power is turned off), then the indicator flashes in blue to show the current sound quality mode.

“Priority on sound quality” mode: 3 times  - -  - - 

SBC, AAC, or aptX is selected automatically.

“Priority on stable connection” mode: 1 time 

SBC

Wireless Noise Canceling Stereo Headset  
MDR-XB950N1

## Supported codecs

---

A codec is an audio coding algorithm used when transmitting sound via a BLUETOOTH connection. The headset supports the following 3 codecs for music playback via an A2DP connection: SBC, AAC, and aptX.

- SBC  
This is an abbreviation for Subband Codec.  
This is the standard audio coding technology used by BLUETOOTH devices.  
All BLUETOOTH devices support SBC.
- AAC  
This is an abbreviation for Advanced Audio Coding.  
AAC is mainly used by Apple products such as iPhones, and it provides higher sound quality than that of SBC.
- aptX  
This is an audio coding technology.  
aptX is used by some Android smartphones, and it provides a lower compression rate and higher sound quality than that of SBC.

With the headset set to the “Priority on sound quality” mode, when music in one of the above codecs is transmitted from a connected device, the headset switches to that codec automatically and plays back the music in the same codec. However, depending on the device to be connected with the headset, you may need to set the device beforehand to listen to music in a different codec on the headset, even if the device supports a codec of higher sound quality than SBC. Refer to the operating instructions supplied with the device regarding setting the codec.

Wireless Noise Canceling Stereo Headset  
MDR-XB950N1

## Receiving a call

You can enjoy a hands-free call with a smartphone or mobile phone that supports the BLUETOOTH profile HFP (Hands-free Profile) or HSP (Headset Profile), via a BLUETOOTH connection.

- If your smartphone or mobile phone supports both HFP and HSP, set it to HFP.
- Operations may vary depending on the smartphone or mobile phone. Refer to the operating instructions supplied with your smartphone or mobile phone.
- This unit supports normal incoming calls only. Calling apps for smartphones and computers are not supported.

## Ring tone

When an incoming call arrives, a ring tone will be heard from the headset, and the indicator (blue) flashes quickly. You will hear either of following ring tones, depending on your smartphone or mobile phone.

- Ring tone set on the headset
- Ring tone set on the smartphone or mobile phone
- Ring tone set on the smartphone or mobile phone only for a BLUETOOTH connection

**1** Connect the headset to a smartphone or mobile phone beforehand.

**2** When you hear a ring tone, press  button on the headset and receive the call.

When an incoming call arrives even while you are listening to music, playback pauses and a ring tone will be heard from the headset.

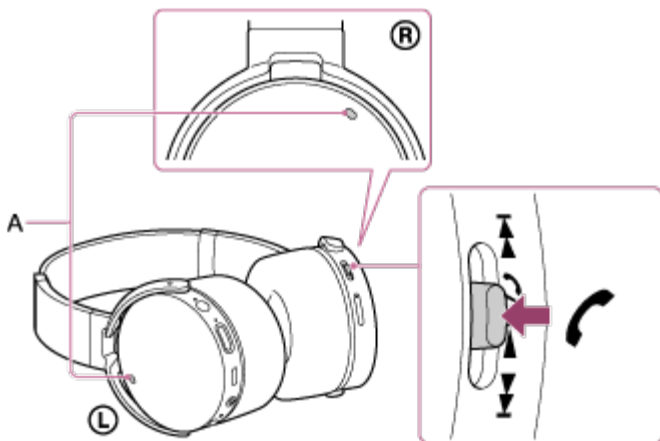

A: Microphone

If no ring tone is heard via the headset

- The headset may not be connected with the smartphone or mobile phone with HFP or HSP. Check the connection status on the smartphone or mobile phone.

- If playback does not pause automatically, operate the headset to pause playback.

3 Press the + or - button to adjust the volume.

When the volume reaches the maximum or minimum, an alarm sounds.

4 To end the call, press the  button on the headset again.

If you received a call during music playback, music playback resumes automatically.

### Note

- Depending on the smartphone or mobile phone, playback may not resume automatically even if you finish the call.
- Use a smartphone or mobile phone at least 50 cm(19 3/4 in.) away from the headset. Noise may result if the headset and the smartphone or mobile phone are too close.

### Hint

- Some smartphones or mobile phones by default receive calls with the phone instead of the headset. With an HFP or HSP connection, switch the call device to the headset by holding the  button down for about 2 seconds or by using your smartphone or mobile phone.
- Volume for a call can be adjusted during a telephone conversation only.
- Volume during a call and volume during music playback can be adjusted independently. Changing the call volume does not change the volume of music playback, and vice versa.

---

### Related Topic

- [How to make a wireless connection to BLUETOOTH devices](#)
- [Making a call](#)
- [Functions for a phone call](#)



If you made a call during music playback, music playback resumes automatically.

### Note

- Use a smartphone or mobile phone at least 50 cm(19 3/4 in.) away from the headset. Noise may result if the headset and the smartphone or mobile phone are too close.

### Hint

- Volume for a call can be adjusted during a telephone conversation only.
- Volume for a call and listening to music can be adjusted independently. Even if you change the volume while playing back music, the volume of a call does not change.

---

### Related Topic

- [How to make a wireless connection to BLUETOOTH devices](#)
- [Receiving a call](#)
- [Functions for a phone call](#)

Wireless Noise Canceling Stereo Headset  
MDR-XB950N1

## Functions for a phone call

---

The available functions may vary depending on the profile supported by your smartphone or mobile phone. Even if the profile is the same, functions may vary depending on the smartphone or mobile phone.

Refer to the operating instructions supplied with your smartphone or mobile phone.

Supported profile: HFP



### During standby/music playback

- Press the  button for about 2 seconds to start the voice dial function of the smartphone/cell phone (\*), activate Siri of the iPhone/iPad, or activate the Google App of the Android smartphone.

### Outgoing call

- Press the  button once to cancel an outgoing call.
- Press the  button for about 2 seconds to change the call device between the headset and the smartphone or mobile phone.

### Incoming call

- Press the  button once to answer a call.
- Press and hold the  button for about 2 seconds to reject a call.

### During call

- Press the  button once to finish a call.
- Press the  button for about 2 seconds to change the call device between the headset and the smartphone or mobile phone.

Supported profile: HSP

### Outgoing call

- Press the  button once to cancel an outgoing call. (\*)

### Incoming call

- Press the  button once to answer a call.

### During call

- Press the  button once to finish a call. (\*)

\* Some devices may not support this function.

- Receiving a call
- Making a call

4-692-591-11(1) Copyright 2017 Sony Corporation

Wireless Noise Canceling Stereo Headset  
MDR-XB950N1

## Using the voice assist function (Siri)

---

By using the Siri feature that comes with iPhone/iPad, you can speak to the headset's microphone to operate the iPhone/iPad. The following shows how to use Siri.

### 1 Turn Siri on.

On iPhone/iPad, select [Settings] — [Siri] to turn Siri on.

The operation above is an example. For details, refer to the operating instructions of the iPhone/iPad.

Note: For details on Siri, refer to the operating instructions or support website of the iPhone/iPad.

### 2 Connect the headset to the iPhone/iPad via BLUETOOTH.

### 3 When the iPhone/iPad is in standby or playing music, press and hold the button to activate Siri.

You hear a startup sound.

### 4 Make a request to Siri through the headset's microphone.

For details on Siri, such as apps which work with Siri, refer to the operating instructions of the iPhone/iPad.

### 5 To continue to request, press the button before Siri is deactivated.

After activating Siri, when a certain time has passed without requests, a beep will sound and Siri will be deactivated.

#### Note

- Siri cannot be activated when you say "Hey Siri" through the headset's microphone even when the iPhone/iPad's [Allow "Hey Siri"] setting is on.

Wireless Noise Canceling Stereo Headset  
MDR-XB950N1

## Using the voice assist function (Google App)

---

By using the Google App feature that comes with the Android smartphone, you can speak to the headset's microphone to operate the Android smartphone.

The following shows how to use the Google App.

### 1 Turn the Google App on.

On the Android smartphone, select [Settings] — [Apps]. A gear icon appears in the top-right corner of the display. Select the gear icon, then [Default Apps] — [Assist & Voice input] — [Assist App], and then set [Assist App] to the Google App. The operation above is an example. For details, refer to the operating instructions of the Android smartphone.

Note: The latest version of the app may be required.

For details on the Google App, refer to the operating instructions or support website of the Android smartphone.

The Google App may not be activated from the headset depending on specifications of the Android smartphone.

### 2 Connect the headset to the Android smartphone via BLUETOOTH.

### 3 When the Android smartphone is in standby or playing music, press and hold the button to activate the Google App.

### 4 Activate the Google App and hear the start-up sound.

### 5 Make a request to the Google App through the headset's microphone.

For details on the Google App, such as apps which work with the Google App, refer to the operating instructions of the Android smartphone.

After activating the Google App, when a certain time has passed without requests, a beep will sound and the Google App will be deactivated

#### Note

- The Google App cannot be activated when you say "OK Google" through the headset's microphone even when the Android smartphone's [OK Google] setting is on.

Wireless Noise Canceling Stereo Headset  
MDR-XB950N1

## What you can do with "Sony | Headphones Connect" app

---

When you install the "Sony | Headphones Connect" app to your smartphone, you can do the following.

- Display the remaining battery of the headset
- Turn noise canceling on/off
- Set CLEAR BASS (Electro Bass Booster)
- Select the sound effect mode (VPT)

For details of the "Sony | Headphones Connect" app, refer to the following URL. You can also check the schedule of app release, corresponding devices and so on.

<http://www.sony.net/hpc/>

The CLEAR BASS and sound effect setting with the app can be also turned on/off with the BASS EFFECT button on the headset.

### Hint

- The Electro Bass Booster and sound effect setting with the app are memorized by the headset. When you set the app once, you can also enjoy the sound effect of the device not installed with the app using the bass effect function on the headset.
- The operation of the "Sony | Headphones Connect" app depends on audio devices. The app specifications and screen design may be changed without prior notice.

---

### Related Topic

- [Installing "Sony | Headphones Connect" app](#)
- [Checking the remaining battery charge](#)
- [Using the noise canceling function](#)
- [Using the bass effect function](#)

Wireless Noise Canceling Stereo Headset  
MDR-XB950N1

## Installing "Sony | Headphones Connect" app

---

- 1 Download the "Sony | Headphones Connect" app from Google Play store or App Store, and install the app to your smartphone.

For details of the "Sony | Headphones Connect" app, refer to the following URL.

<http://www.sony.net/hpc/>



**Sony Headphones Connect** 🔍

- 2 After installing the app, launch the "Sony | Headphones Connect" app.

Wireless Noise Canceling Stereo Headset  
MDR-XB950N1

## Precautions

---

### Note on static electricity

- Static electricity accumulated in the body may cause mild tingling in your ears. To minimize the effect, wear clothes made from natural materials.

### Others

- Be careful not to catch your finger in the unit when folding.
- When you use the unit as wired headphones, use the supplied headphone cable only. Make sure that the headphone cable is firmly inserted.
- Do not place this headset in a place exposed to humidity, dust, soot or steam, or subject to direct sunlight. Do not leave the headset in a car for a long time. It may cause a malfunction.
- Using the BLUETOOTH device may not function on mobile phones, depending on radio wave conditions and location where the device is being used.
- Listening with this headset at high volume may affect your hearing.
- For traffic safety, do not use this headset while driving or cycling.
- Do not use the headset in places where it would be dangerous if you are unable to hear ambient sound, such as at railroad crossings, train station platforms, pedestrian crossings, and construction sites.
- Do not put weight or pressure on this headset as it may cause the headset to deform during long storage.
- Do not subject the headset to excessive shock.
- Clean the headset with a soft dry cloth.
- Do not expose the headset to water. The headset is not waterproof. Remember to follow the precautions below.
  - Be careful not to drop the headset into a sink or other container filled with water.
  - Do not use the headset in humid locations or bad weather, such as in the rain or snow.
  - Do not get the headset wet. If you touch the headset with wet hands, or put the headset in a damp article of clothing, the headset may get wet and this may cause a malfunction of the headset.
- If you experience discomfort after using the BLUETOOTH device, stop using the BLUETOOTH device immediately. Should any problem persist, consult your nearest Sony dealer.
- The earpads may deteriorate due to long-term storage or use.
- Optional replacement earpads can be ordered from your nearest Sony dealer.
- If you have any questions or problems concerning this headset that are not covered in this manual, please consult your nearest Sony dealer.

Wireless Noise Canceling Stereo Headset  
MDR-XB950N1

## Trademarks

---

- The BLUETOOTH word mark and logos are owned by the Bluetooth SIG, Inc. and any use of such marks by Sony Corporation is under license.
- The N-Mark is a trademark or registered trademark of NFC Forum, Inc. in the United States and in other countries.
- Android and Google Play are trademarks of Google Inc.
- iPad, iPhone, iPod touch and Siri are trademarks of Apple Inc., registered in the U.S. and other countries.
- Microsoft and Windows are registered trademarks or trademarks of Microsoft Corporation in the United States and/or other countries.
- Mac and Mac OS are trademarks of Apple Inc., registered in the U.S. and other countries.
- Qualcomm is a trademark of Qualcomm Incorporated, registered in the United States and other countries, used with permission. aptX is a trademark of Qualcomm Technologies International, Ltd., registered in the United States and other countries, used with permission.

Other trademarks and trade names are those of their respective owners.

Wireless Noise Canceling Stereo Headset  
MDR-XB950N1

## Customer support websites

---

Please access the following support website to get the support information about your headset:

For customers in the U.S.A:

<http://esupport.sony.com/>

For customers in Canada:

<http://esupport.sony.com/CA/>

For customers in Latin America:

<http://esupport.sony.com/LA/>

For customers in European countries:

[www.sony.eu/support](http://www.sony.eu/support)

For customers in China:

<https://service.sony.com.cn/>

For customers in other countries/regions:

<http://www.sony-asia.com/>

Wireless Noise Canceling Stereo Headset  
MDR-XB950N1

## What can I do to solve a problem?

---

If the headset does not function as expected, try the following steps to resolve the issue.

- Find the symptoms of the issue in this Help Guide, and try any corrective actions listed.
- Connect the headset to a computer to charge the battery.  
You may be able to resolve some issues by charging the battery.
- Reset the headset.
- Initialize the headset.  
This operation resets volume settings, etc., and deletes all pairing information.
- Look up information on the issue on the customer support website.

If the operations above do not work, consult your nearest Sony dealer.

---

### Related Topic

- [Charging the headset](#)
- [Customer support websites](#)
- [Resetting the headset](#)
- [Initializing the headset to restore factory settings](#)

Wireless Noise Canceling Stereo Headset  
MDR-XB950N1

The headset is not turned on.

---

- Charge the battery of the headset.
  - The headset cannot be turned on while charging the battery. Remove the micro-USB cable from the headset, and then turn on the headset again.
- 

Related Topic

- [Charging the headset](#)
- [Checking the remaining battery charge](#)

Wireless Noise Canceling Stereo Headset  
MDR-XB950N1

## Charging cannot be done.

---

- Check that you are using the micro-USB cable supplied.
  - Check that the micro-USB cable is connected to the headset and the computer firmly.
  - Check that the computer is turned on.
  - Check that the computer is not in standby, sleep or hibernation mode.
  - When using Windows 8.1 update using Windows Update.
- 

### Related Topic

- [Charging the headset](#)

Wireless Noise Canceling Stereo Headset  
MDR-XB950N1

## Charging time is too long.

---

- Check that the headset and the computer are directly connected, not via a USB hub.
- 

### Related Topic

- [Charging the headset](#)

Wireless Noise Canceling Stereo Headset  
MDR-XB950N1

The headset cannot be recognized by a computer.

- 
- The micro-USB cable is not connected properly to the USB port of the computer. Connect the micro-USB cable again.
  - Check that the headset and the computer are directly connected, not via a USB hub.
  - A problem may have occurred with the connected USB port of the computer. Connect to another USB port if it is available.
  - Try the USB connection procedure again in cases other than those stated above.
  - Check that you are using the micro-USB cable supplied.

Wireless Noise Canceling Stereo Headset  
MDR-XB950N1

The remaining battery charge of the headset is not displayed on the screen of an iPhone, iPad, or iPod touch.

- 
- The remaining battery charge is shown only on the screen of an iPhone, iPad, or iPod touch (iOS 5.0 or later) that supports HFP (Hands-free Profile).
  - Make sure that the iPhone, iPad or iPod touch is connected with HFP (Hands-free Profile). Otherwise, the remaining battery charge will not be displayed correctly.

Wireless Noise Canceling Stereo Headset  
MDR-XB950N1

## No sound

---

- Check that both the headset and the connected device (i.e., smartphone) are turned on.
  - An A2DP BLUETOOTH connection is not made between the headset and the BLUETOOTH device. Use the BLUETOOTH device and make an A2DP BLUETOOTH connection.
  - Turn up the volume of the headset and the connected device (i.e., smartphone).
  - Check that the connected device is playing back.
  - If you are connecting a computer to the headset, make sure the audio output setting of the computer is set for a BLUETOOTH device.
  - Pair the headset and the BLUETOOTH device again.
  - Check that the headphone cable is connected firmly.
- 

## Related Topic

- [How to make a wireless connection to BLUETOOTH devices](#)
- [Listening to music from a device connected via BLUETOOTH](#)

Wireless Noise Canceling Stereo Headset  
MDR-XB950N1

## Low sound level

---

- Turn up the volume of the headset and the connected device.

Wireless Noise Canceling Stereo Headset  
MDR-XB950N1

## Low sound quality

---

- Turn down the volume of the connected device.
- Keep the headset away from a microwave oven, Wi-Fi device, etc.
- Bring the headset and the BLUETOOTH device closer together. Remove any obstacles between the headset and the BLUETOOTH device.
- Keep the headset away from a TV.
- Switch the BLUETOOTH connection to A2DP by operating the BLUETOOTH device when HFP or HSP is set.
- If you connect a device with a built-in radio or tuner to the headset, broadcasts may not be received, or sensitivity may be reduced. Locate the headset farther away from the device and check that you can listen to the broadcasts satisfactorily.
- If you have previously connected the headset to this BLUETOOTH device, only an HFP/HSP BLUETOOTH connection may be made when the headset is turned on. If this happens, use the BLUETOOTH device and make an A2DP BLUETOOTH connection.
- When you listen to music from a computer on the headset, sound quality may be poor for the first few seconds after a connection is made. This is caused by the computer transmitting music at sound quality for communications at first, and it is not a malfunction.  
If the sound quality does not improve after a few seconds, press the  button on the headset once during playback. Or, operate the computer to make an A2DP connection. Refer to the operating instructions supplied with your computer for computer operation.

Wireless Noise Canceling Stereo Headset  
MDR-XB950N1

## Sound skips frequently during playback.

- Set the headset to the “Priority on stable connection” mode. For details, refer to [“Switching the sound quality mode.”](#)
- Remove any obstacles between the antenna of the BLUETOOTH device to be connected and the built-in antenna of the headset. The antenna of the headset is built into the part shown in the dotted line below.

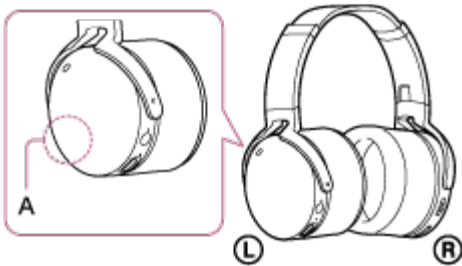

A: Location of the built-in antenna

- BLUETOOTH communications may be disabled, or noise or audio dropout may occur under the following conditions.
  - There is a human body between the headset and the BLUETOOTH device. This situation may be improved by placing the BLUETOOTH device facing the antenna of the headset.
  - There is an obstacle, such as metal or wall, between the headset and the BLUETOOTH device.
  - A device using 2.4 GHz frequency, such as a Wi-Fi device, cordless telephone, or microwave oven, is in use near this headset.
- The situation may be improved by changing the wireless playback quality settings or fixing the wireless playback mode to SBC on the transmitting device. For details, refer to the operating instructions supplied with the transmitting device.

Wireless Noise Canceling Stereo Headset  
MDR-XB950N1

The noise canceling effect is not sufficient.

---

- Make sure that the noise canceling function is turned on (the indicator (green) lights up).
  - Adjust the earpad position to fit your ears.
  - The noise canceling function is effective in low frequency ranges such as airplanes, trains, offices, near air-conditioning, and is not as effective for higher frequencies, such as human voices.
- 

Related Topic

- [What is noise canceling?](#)
- [Using the noise canceling function](#)
- [About the Automatic AI noise canceling function](#)

Wireless Noise Canceling Stereo Headset  
MDR-XB950N1

Pairing cannot be done.

- 
- Bring the headset and the BLUETOOTH device within 1 m(3 feet) from each other.
  - When you turn on the headset for the first time after purchasing, initializing, or repairing it, the headset enters pairing mode automatically. Pair the headset with a BLUETOOTH device. When you want to pair a 2nd or subsequent device, press and hold the  button of the headset for about 7 seconds to enter pairing mode.
  - When you pair the headset with devices again after initializing or repairing the headset, information for pairing with the headset remaining on the iPhone or other device may prevent you from pairing them successfully. In this case, delete the pairing information of the headset from the device, and then pair them again.
- 

Related Topic

- [About the indicator](#)
- [How to make a wireless connection to BLUETOOTH devices](#)
- [Initializing the headset to restore factory settings](#)

Wireless Noise Canceling Stereo Headset  
MDR-XB950N1

## Unable to connect the headset to a BLUETOOTH device with one-touch connection (NFC)

- Keep the smartphone close to the headset until the smartphone reacts. If you fail to connect, move the smartphone slowly on the N-Mark of the headset.
- Check that the NFC function of the smartphone is set to on.
- If the smartphone is in a case, remove it.
- NFC reception sensitivity varies depending on the device. If you repeatedly fail to connect the headset with a smartphone by one touch, connect it to the headset by on-screen operation on the smartphone.
- You cannot make a one-touch connection (NFC) while charging the battery because the headset cannot be turned on. Finish charging first, and then make the one-touch connection (NFC).
- You cannot make a one-touch connection (NFC) when the headphone cable is connected to the INPUT jack. Remove the headphone cable from the headset.

### Related Topic

- [One-touch connection \(NFC\) with a smartphone \(Android 4.1 or later\)](#)

Wireless Noise Canceling Stereo Headset  
MDR-XB950N1

## Unable to make a BLUETOOTH connection

---

- Check that the headset is turned on.
  - Check that the BLUETOOTH device is turned on and the BLUETOOTH function is on.
  - Connection with the BLUETOOTH device may not be memorized on the headset. Make a BLUETOOTH connection from the BLUETOOTH device to the headset soon after pairing is complete.
  - The BLUETOOTH device is in sleep mode.
  - The BLUETOOTH connection is terminated. Make the BLUETOOTH connection again.
- 

### Related Topic

- [About the indicator](#)
- [How to make a wireless connection to BLUETOOTH devices](#)

Wireless Noise Canceling Stereo Headset  
MDR-XB950N1

## Distorted sound

---

- Keep the headset away from a microwave oven, Wi-Fi device, etc.

Wireless Noise Canceling Stereo Headset  
MDR-XB950N1

The BLUETOOTH wireless communication range is short, or the sound skips.

- Set the headset to the “Priority on stable connection” mode. For details, refer to “[Switching the sound quality mode.](#)”
- Remove any obstacles between the antenna of the BLUETOOTH device to be connected and the built-in antenna of the headset. The antenna of the headset is built into the part shown in the dotted line below.

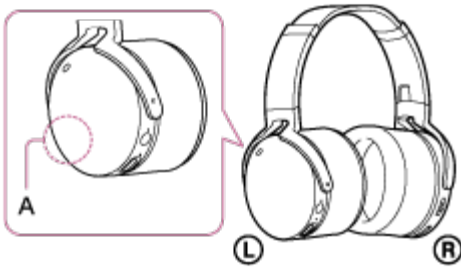

A: Location of the built-in antenna

- BLUETOOTH communications may be disabled, or noise or audio dropout may occur under the following conditions.
  - There is a human body between the headset and the BLUETOOTH device. This situation may be improved by placing the BLUETOOTH device facing the antenna of the headset.
  - There is an obstacle, such as metal or wall, between the headset and the BLUETOOTH device.
  - A device using 2.4 GHz frequency, such as a Wi-Fi device, cordless telephone, or microwave oven, is in use near this headset.
- The situation may be improved by changing the wireless playback quality settings or fixing the wireless playback mode to SBC on the transmitting device. For details, refer to the operating instructions supplied with the transmitting device.

Wireless Noise Canceling Stereo Headset  
MDR-XB950N1

The headset does not operate properly.

---

- Reset the headset. Pairing information is not deleted by this operation.
  - If you cannot use the headset even after resetting it, initialize the headset.
- 

Related Topic

- [Resetting the headset](#)
- [Initializing the headset to restore factory settings](#)

Wireless Noise Canceling Stereo Headset  
MDR-XB950N1

## No voice from callers

---

- Check that both the headset and the connected device (i.e., smartphone) are turned on.
  - Turn up the volume of the headset and the connected device (i.e., smartphone).
  - Check that output of the BLUETOOTH device is set for the headset.
  - Select an HFP or HSP BLUETOOTH connection by operating the BLUETOOTH device.
  - If you are listening to music using the headset, stop playback, press the  button on the headset and talk.
- 

### Related Topic

- [How to make a wireless connection to BLUETOOTH devices](#)
- [Receiving a call](#)
- [Making a call](#)

Wireless Noise Canceling Stereo Headset  
MDR-XB950N1

## Low voice from callers

---

- Turn up the volume of the headset and the connected device.

Wireless Noise Canceling Stereo Headset  
MDR-XB950N1

## Resetting the headset

---

If the headset cannot be turned on, or if it cannot be operated even when it is turned on, connect the headset to a booted computer using the supplied micro-USB cable, then press the  button and BASS EFFECT button simultaneously. The headset will be reset. Pairing information is not deleted.

To charge the headset after resetting, disconnect and reconnect the micro-USB cable.

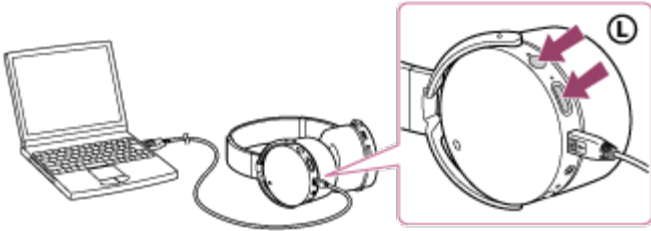

If the headset does not operate correctly even after resetting, initialize the headset to restore factory settings.

---



### Related Topic

- [Initializing the headset to restore factory settings](#)

Wireless Noise Canceling Stereo Headset  
MDR-XB950N1

## Initializing the headset to restore factory settings

---

Disconnect the micro-USB cable, turn off the headset, then press and hold the  button and  button simultaneously for more than 7 seconds.

The indicator (blue) flashes 4 times () , and the headset is reset to the factory settings. All pairing information is deleted.

If the headset does not operate correctly even after initializing, consult your nearest Sony dealer.