

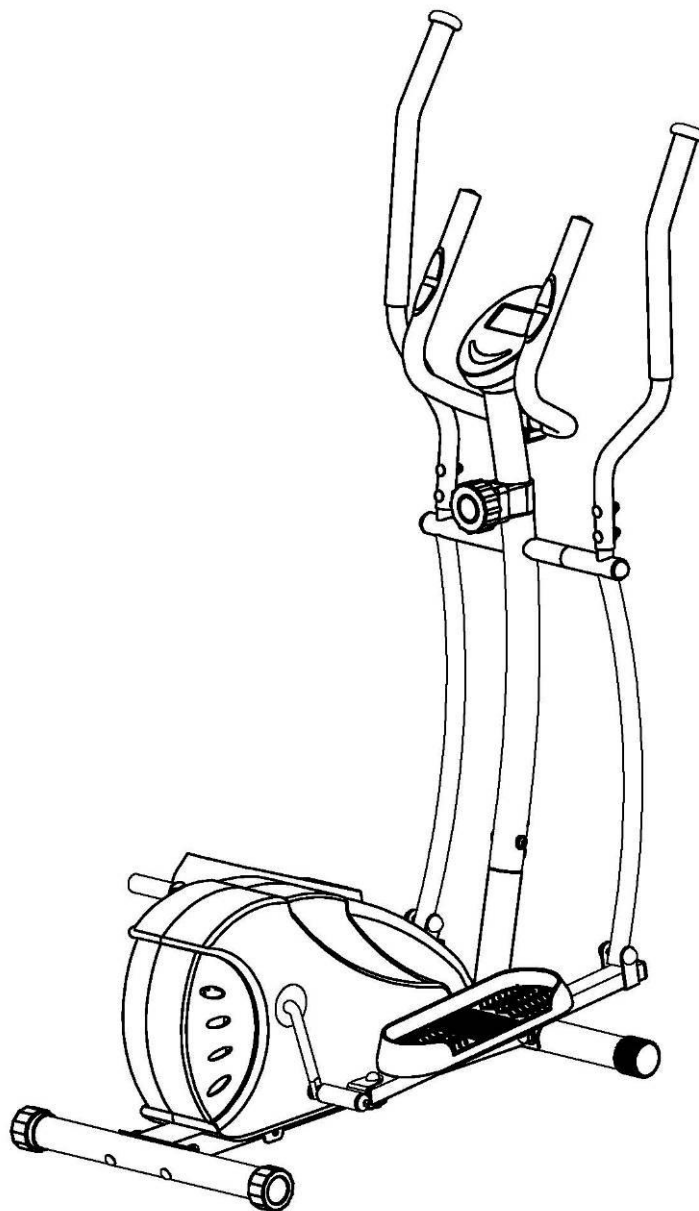

MAGNETIC ELLIPTICAL TRAINER SF-E905 USER MANUAL



IMPORTANT! Read all instructions carefully before using this product. Retain owner's manual for future reference. For customer service, please contact: support@sunnyhealthfitness.com

IMPORTANT SAFETY INFORMATION

We thank you for choosing our product. To ensure your safety and health, please use this equipment correctly. It is important to read this entire manual before assembling and using the equipment. Safe and effective use can only be assured if the equipment is assembled, maintained, and used properly. It is your responsibility to ensure that all users of the equipment are informed of all warnings and precautions.

1. Before starting any exercise program you should consult your physician to determine if you have any medical or physical conditions that could put your health and safety at risk or prevent you from using the equipment properly. Your physician's advice is essential if you are taking any medication that may affect your heart rate, blood pressure, or cholesterol level.
2. Be aware of your body's signals. Incorrect or excessive exercise can damage your health. Stop exercising if you experience any of the following symptoms: pain, tightness in your chest, irregular heartbeat, shortness of breath, lightheadedness, dizziness, or feelings of nausea. If you do experience any of these conditions, you should consult your physician before continuing with your exercise program.
3. Keep children and pets away from the equipment. The equipment is designed for adult use only.
4. Use the equipment on a solid, flat level surface with a protective cover for your floor or carpet. To ensure safety, the equipment should have at least 2 feet of free space all around it.
5. Ensure that all nuts and bolts are securely tightened before using the equipment. The safety of the equipment can only be maintained if it is regularly examined for damage and/or wear and tear.
6. It is recommended that you lubricate all moving parts on a monthly basis.
7. Always use the equipment as indicated. If you find any defective components while assembling or checking the equipment, or if you hear any unusual noises coming from the equipment during exercise, stop using the equipment immediately and don't use the equipment until the problem has been rectified.
8. Wear suitable clothing while using the equipment. Avoid wearing loose clothing that may become entangled in the equipment.
9. Do not place fingers or objects into the moving parts of the equipment.
10. The maximum weight capacity of this unit is 220 pounds.
11. This equipment is not suitable for therapeutic use.
12. Move with caution when lifting and moving the equipment. Always use proper lifting technique and seek assistance if necessary.
13. Your product is intended for use in cool, dry conditions. You should avoid storage in extreme cold, hot, or damp areas as this may lead to corrosion and other related problems.
14. This equipment is designed for indoor use only! It is not intended for commercial use!

EXPLODED DIAGRAM

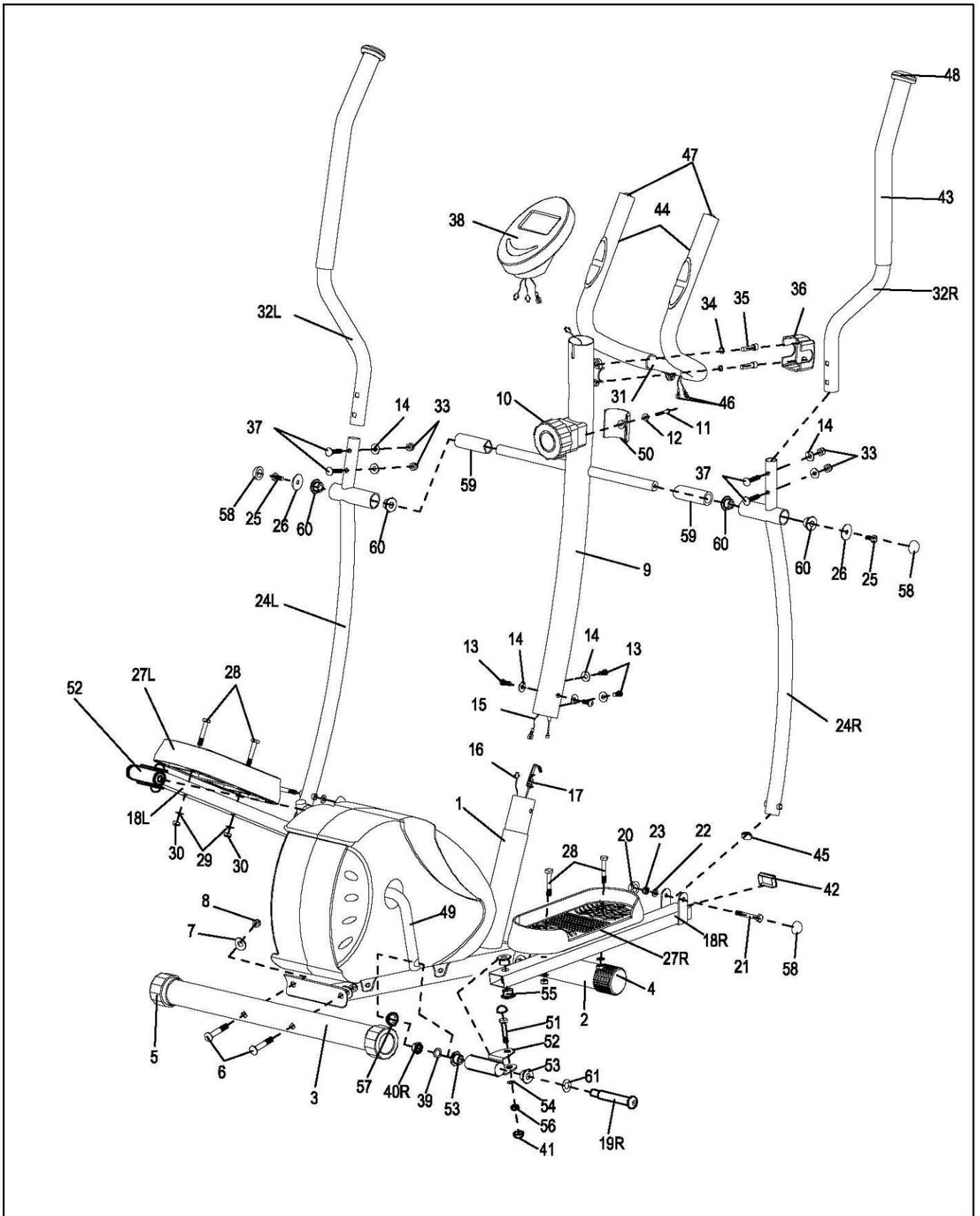

PARTS LIST

Part No.	Description	QTY	Part No.	Description	QTY
1	Main Frame	1	31	Armrest	1
2	Front Stabilizer	1	32L/R	Handlebar	2
3	Rear Stabilizer	1	33	Domed Nut	4
4	Roller Cap	2	34	Spring Washer	2
5	Leveler Cap	2	35	Hex Bolt	2
6	Carriage Bolt	4	36	Decorative Cover	1
7	Arc Washer	4	37	Carriage Bolt	4
8	Domed Nut	4	38	Meter	1
9	Handlebar Post	1	39	Spring Washer	2
10a	Tension Controller	1	40L/R	Nylon Nut (L/R)	2
10b	Tension Cable		41	Nut Cap S17	4
11	Phillips Screw	1	42	Square End Cap	2
12	Flat Washer	1	43	Foam Grip	2
13	Allen Bolt	4	44	Foam Grip	2
14	Arc Washer	8	45	Round End Cap	2
15	Upper Sensor Wire	1	46	Pulse Sensor Wire	2
16	Lower Sensor Wire	1	47	Spherical Cap	2
17	Tension Hook	1	48	Mushroom Cap	2
18L/R	Pedal Support Tube (L/R)	2	49	Crank Arm	1
19L/R	Locking Bolt (L/R)	2	50	Tension Controller Cover	1
20	Nut Cap S13	2	51	Hex Bolt	2
21	Hex Bolt	2	52	Connecting Joint	2
22	Flat Washer	2	53	Axle Bushing 1	4
23	Nylon Nut	2	54	Flat Washer D10	2
24L/R	Swing Bar (L/R)	2	55	Alloy Bushing	4
25	Hex Bolt	2	56	Nylon Nut M10	2
26	Flat Washer	2	57	Nut Cap S19	2
27L/R	Pedal (L/R)	2	58	Nut Cap S14	4
28	Hex Bolt	4	59	Spacer	2
29	Flat Washer	4	60	Axle Bushing 2	4
30	Nylon Nut	4	61	Wave Washer	2

NOTE: Most of the listed assembly hardware have been packaged separately but some hardware items have been preinstalled on the machine. In these instances, simply remove and reinstall the hardware as required.

Please reference the individual assembly steps and make note of all preinstalled hardware.

ASSEMBLY INSTRUCTIONS

STEP 1: *Install the Front Stabilizer & Rear Stabilizer*

Attach the Front Stabilizer (No. 2) and Rear Stabilizer (No. 3) onto the Main Frame (No. 1). Secure with the Carriage Bolts (No. 6), Arc Washers (No. 7) and Domed Nuts (No. 8) which are preassembled to the stabilizer.

★ Ensure that ALL bolts and washers are in place and partially threaded in before completely tightening any ONE bolt.

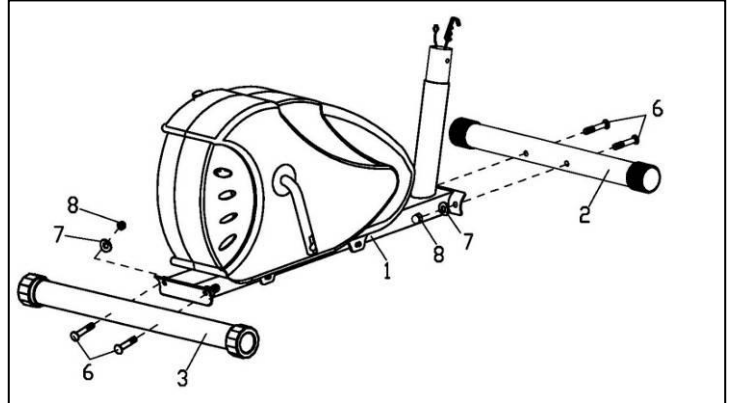

STEP 2: *Install the Tension Controller and the Handlebar Post*

Connect the Lower Sensor Wire (No. 16) to the Upper Sensor Wire (No. 15), and then connect Tension Hook (No. 17) with Tension Cable (No. 10b) as shown in *Figure A*.

CAUTION:

Please make sure the Tension Controller (No. 10a) is set at resistance level 1 before you connect the Tension Cable. This will ensure the wires are at their longest reaching point. Also, having someone else hold the Handlebar Post (No. 9) will make the connection easier when you connect part (No. 10b) to part (No. 17). You may need them to pull the post upward to stretch the cable. (As seen in *Figure A*, Picture 3)

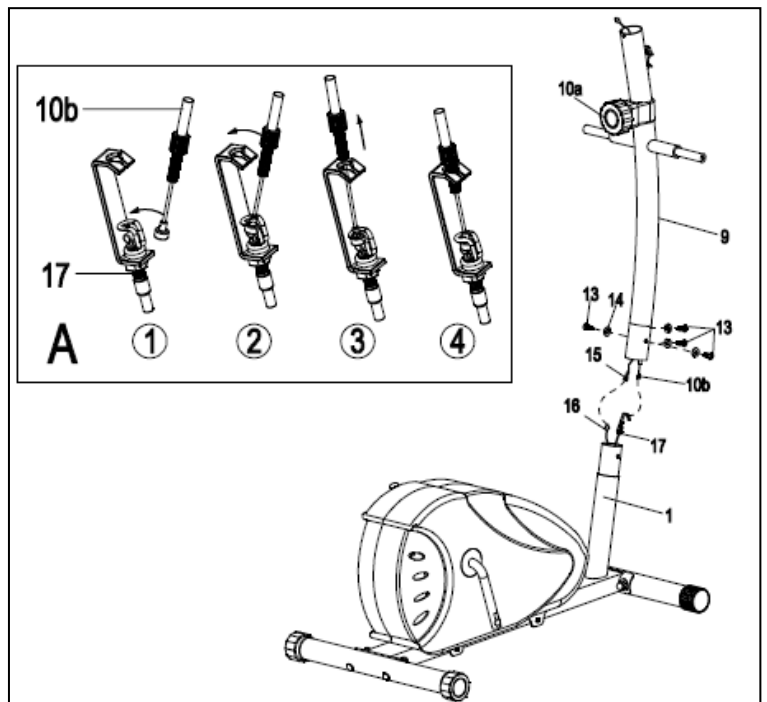

Insert the Handlebar Post (No. 9) into the post of the Main Frame (No. 1); secure in place with Allen Bolts (No. 13) and Arc Washers (No. 14) which are pre-attached to the Main Section.

★ Ensure that ALL bolts and washers are in place and partially threaded in before completely tightening any ONE bolt.

STEP 3: Install Pedal Support Tube and Swing Bar

★ **IMPORTANT:** Please read entire page before starting this step, and note all cautions.

A: Fix the Swing Bar (No. 24L/R) to the long axle of the Handlebar Post (9) with Hex Bolt (No. 25) and Flat Washer (No. 26).

Note: Do not fasten tightly yet

B: Fix the Pedal Support Tube (No. 18L/R) to the Crank (No. 49) with Locking Bolt (No. 19L/R), Wave Washer (No. 61), then put on Spring Washer (No. 39) and Nylon Nut (No. 40L/R) to the end of Locking Bolt (No. 19L/R).

IMPORTANT! Part 19 is labeled L for LEFT and R for RIGHT. Please

make sure to turn 19L counter-clockwise to tighten, and 19R clockwise to tighten. Do not try to install the Left Bolt on the Right Crank or vice versa; the Left Bolt is meant only for the Left Crank, same for the Right Bolt.

The LEFT Nylon Nut (No. 40L) is Silver, while the RIGHT Nylon Nut (No. 40R) is Black

Note: Do not fasten tightly yet

The Right and Left Locking Bolt (No. 19R/L) must fully penetrate the nylon ring of the Nylon Nut (No. 40L/R) inside the Pedal Arm Joint and the Crank. This will ensure the stability and durability of your elliptical.

In order to install the Locking Bolt (No. 19) properly, keep it perfectly straight as the bolt goes through the pedal arms and into the crankshaft. **If the Locking Bolt is connected to the crankshaft at an angle, permanent damage to both the bolt and the crank may occur.**

If you experience any trouble with this step; please STOP and try the alternate directions on the next page before continuing. Incorrect installation can result in permanent damage to the item.

C: Fasten the Swing Bar (No. 24L/R) and the Pedal Support Tube (No. 18L/R) tightly with Hex Bolt (No. 21), Flat Washer (No. 22), and Nylon Nut (No. 23).

D: Fasten Hex Bolt (No. 25) and Nylon Nut (No. 40L/R) tightly now. Cover all the Nut Caps (No. 20) (No. 58) (No. 57).

★ Ensure that ALL bolts and washers are in place and partially threaded in before completely tightening any ONE bolt.

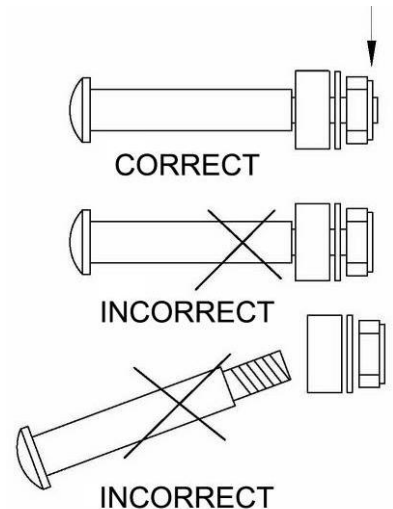
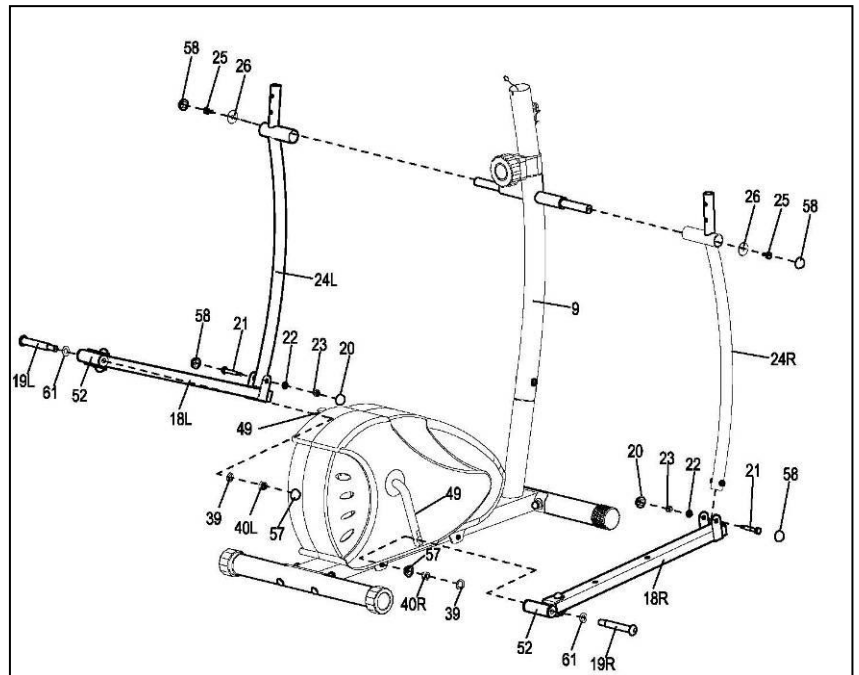

If you have trouble connecting this part, try this alternate assembly suggestion:

Step 1

Disconnect the Connecting Joint (52 L/R) from the Pedal Support Tube (18L/R)

Step 2

Insert the Locking bolt (19 L/R) through the hole of the Connecting Joint (52 L/R) then screw the Locking bolt in the Crank arm (49).
Remember when assembling the left side, you must screw counter-clockwise to tighten
Connect the Spring washer (39) and Nylon nut (40 L/R) and attach the End cap (41).
You can now reattach the Connecting Joint (52 L/R) to the Support Tube (18L/R).

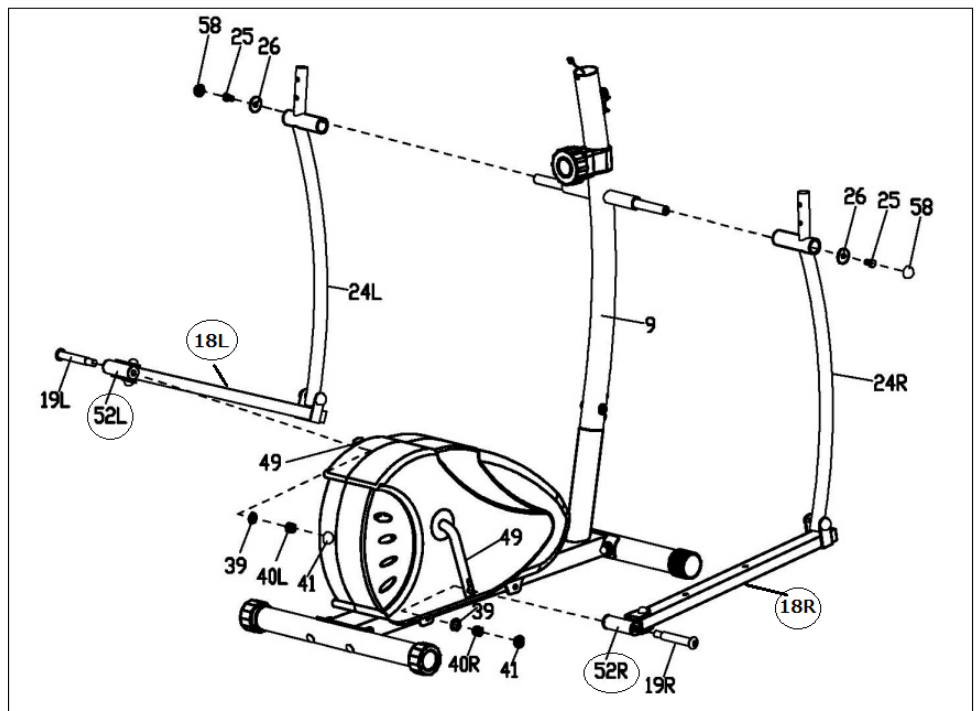

STEP 4: Install the Pedals

Secure the Pedals (No. 27L/R) to the Pedal Support Tube (No. 18L/R) respectively using Hex Bolt (No. 28), Flat Washer (No. 29) and Nylon Nut (No. 30), viewed from the rider's seated position.

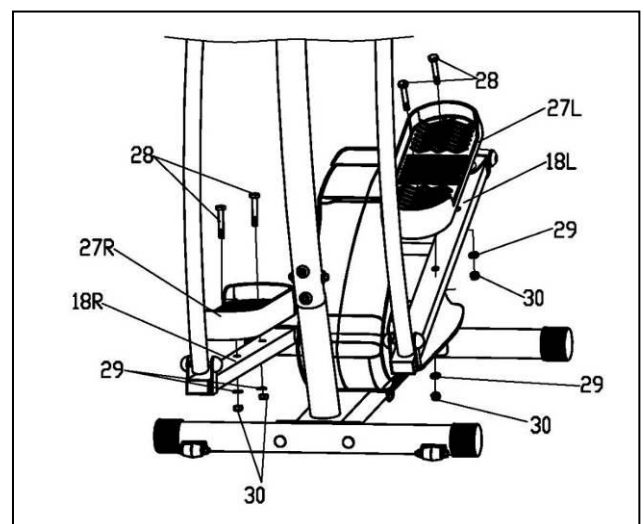

STEP 5: *Install the Handlebar and Armrest*

A: Fix the Armrest (No. 31) onto the Handlebar Post (No. 9) using the Spring Washers (No. 34) and Hex Bolts (No. 35) which came pre-attached to the Handlebar Post. Then pull the Pulse Sensor Wire (No. 46) through the small hole on the front of the Handlebar Post (No. 9) and pull them out of the top (as seen in diagram on Step 6). Finally, attach the Decorative Cover (No. 36) onto the Armrest (No. 31).

B: Fix the Handlebar (No. 32L/R) on the Swing Bar (No. 24L/R) with Carriage Bolt (No. 37), Arc Washer (No. 14) and Domed Nut (No. 33).

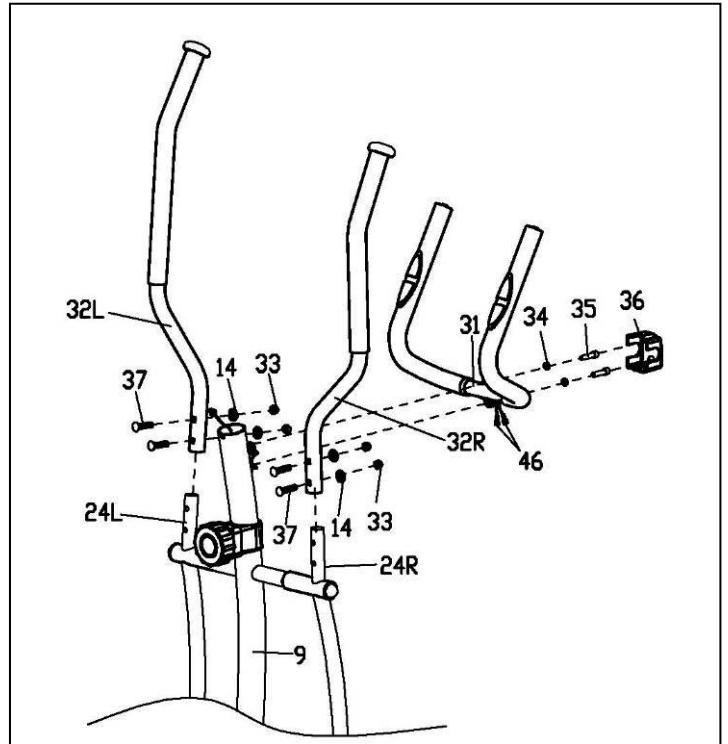

NOTE: If the Handlebar (No. 32L/R) rubs the Armrest (No. 31) during the workout, please check if you assembled the correct parts to each side.

You should attach 32L to 24L (check the label on parts, Left is marked with an 'L').

You should attach 32R to 24R (check the label on parts, Right is marked with an 'R').

STEP 6: *Install the Meter*

Connect the Pulse Sensor Wires (No. 46) and Upper Sensor Wire (No. 15) to the Meter (No. 38) respectively. **NOTE: To avoid damaging the wires, push them back into the Handlebar post before sliding the Meter on.** Align the slot of the Handlebar post to the bulge inside the Meter (No. 38) then slide it onto the Handlebar Post (No. 9) slowly.

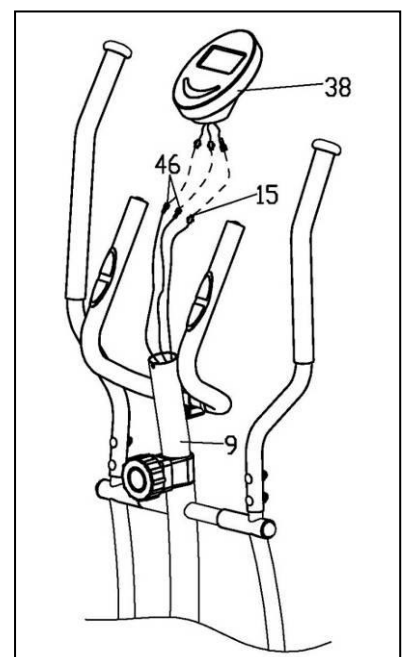

THE ASSEMBLY IS NOW COMPLETE!

EXERCISE COMPUTER

FUNCTION KEYS:

1. MODE:

A. Press to select functions.

B. Press and hold the MODE button for 6 seconds to reset time, distance and calories.

2. SET: Press to set values of time, pulse, distance and calories when not in scan mode.

A. Press the MODE button to cycle through functions: time, distance and calories to select desired function.

B. Use the SET button to set a value for time, distance or calories. The value of a function will be set on a countdown.

C. Press the MODE button once more, to save the function value you've created.

3. RESET: Press to reset time, pulse, distance and calories to zero when not in scan mode.

FUNCTIONS:

1. SCAN: Press MODE button until "▼" appears at SCAN position (or until "SCAN" appears), the computer will rotate through all 5 functions: Time, Speed, Distance, Calories and Total Distance. Each display will be held for 6 seconds.

2. TIME: Counts the total time of the exercise from start to finish.

3. SPEED: Displays the current speed.

4. DISTANCE (DIST): Counts the distance of an exercise from start to finish.

5. CALORIES (CAL): Counts the amount of total calories burned during an exercise from start to finish.

6. TOTAL DISTANCE (ODO): Counts the total distance after installing the batteries.

7. AUTO ON/OFF & AUTO START/STOP: If the wheel is put into motion, or any button is pressed the computer will become active, and shall remain active while either of these two things continue to be done, however without any signal for 4 minutes, the power (computer), will turn off automatically.

8. PULSE RATE (If Available): Press MODE button until "▼" appears at PULSE position, (or until " V " appears). In order properly measure your pulse rate, you must place both your palms on the contact pads located on the handlebar next to the seat, once you have done this the computer will show your current heart beat rate in beats per minute (BPM) on the LCD after 3~4 seconds.

Note: During the process of "pulse measurement", as a result of the contact jamming, the measurement value may be higher than virtual pulse rate during the first 2~3 seconds, after which it will return to normal level. To ensure testing accuracy, it is suggested that user test pulse during stop/pause exercise to avoid any possible influence. The measurement value cannot be regarded as the basis of medical treatment.

9. ALARM: The functions of time, distance and calorie can be set to countdown, if any of the above value goes to zero, the computer will alarm for 15 seconds.

Press MODE to select the function, then press SET to adjust the value.

Note:

- The computer containing only the "MODE" button does not have ALARM function.
- The computer can be programmed before delivery with Metric or Imperial system. If you find "M" in left side of monitor screen, it's an Imperial system and the unit will be expressed as mile.

SPECIFICATIONS:

FUNCTION	Auto Scan	Every 6 seconds
	Running Time	00:00 ~ 99:59 (Minute: Second)
	Current Speed	The max pick-up signal is 999.9KM/H or MILE/H (or 1500RPM)
	Trip Distance	0.00 ~ 99.99 KM or MILE
	Calories	0 ~ 999.9 Kcal
	Total Distance	0 ~ 999.9 KM or MILE
	Pulse Rate	40-240BPM
Battery Type		2 pcs of SIZE-AA
Operating Temperature		0 C ~ 40°C (32°F ~ 104°F)
Storage Temperature		-10C ~ 60C (14°F ~ 140°F)

USING YOUR ELLIPTICAL BIKE

Using your elliptical bike will provide you with several benefits. It will improve your physical fitness, tone your muscles and in conjunction with a calorie controlled diet, help you lose weight.

WARM-UP PHASE

The purpose of warming up is to prepare your body for exercise and to minimize injuries. Warm up for two to five minutes before strength-training or aerobic exercising. Perform activities that raise your heart rate and warm the working muscles. Activities may include brisk walking, jogging, jumping jacks, jump rope, and running in place.

STRETCHING

Stretching while your muscles are warm after a proper warm-up and again after your strength or aerobic training session is very important. Muscles stretch more easily at these times because of their elevated temperature, which greatly reduces the risk of injury. Stretches should be held for 15 to 30 seconds. DO NOT BOUNCE.

Remember always to check with your physician before starting any exercise program.



EXERCISE PHASE

This is the stage where you put the effort in. After regular use, the muscles in your legs will become more flexible. Work at your own pace and be sure to maintain a steady tempo throughout. The rate of work should be sufficient to raise your heartbeat into the target zone shown on the graph below.

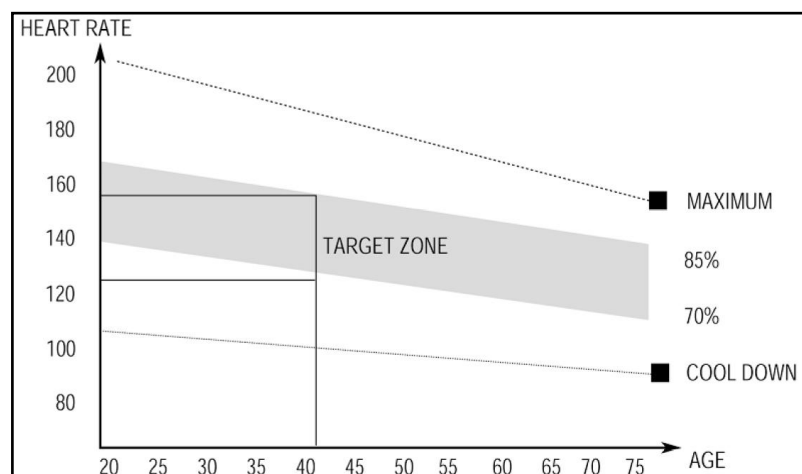

COOL-DOWN PHASE

The purpose of cooling down is to return the body to its normal or near normal, resting state at the end of each exercise session. A proper cool-down slowly lowers your heart rate and allows blood to return to the heart.

TROUBLE SHOOTING

1. If you find there is no difference between tension level 1 to level 8, please check the connection of the tension cable. Please see Diagram A under Step 2.
2. If the meter does not show numbers correctly, please check the batteries. If the meter does not count the speed and time, please check the connections of Upper Sensor Wire (15) to the Meter (38) and Upper Sensor Wire (15) to Lower Sensor Wire (16).
3. If you have difficulty putting Part #19 into the Crank Arm (49), please try moving the Crank Arm (49) to a different angle. *Keep in mind the Left Locking Bolt (19L) has reversed threading and must be installed by turning counter-clockwise.
4. If you hear any noise when using the machine, please check if part #19, #21, #26 and #52 are loose. You may remove these parts and add some lubricant oil to eliminate all noise possibilities, remember to tighten all the parts securely.
5. When you first use the machine, if you hear any unusual noises from the inside of the chain cover, please loosen the screws on the chain cover about two rotations, then push the chain cover up a little bit; finally, fasten the screws you loosened before. See the following diagram. (During shipping, the chain cover can be dislocated, and the flywheel may rub on the chain cover.)

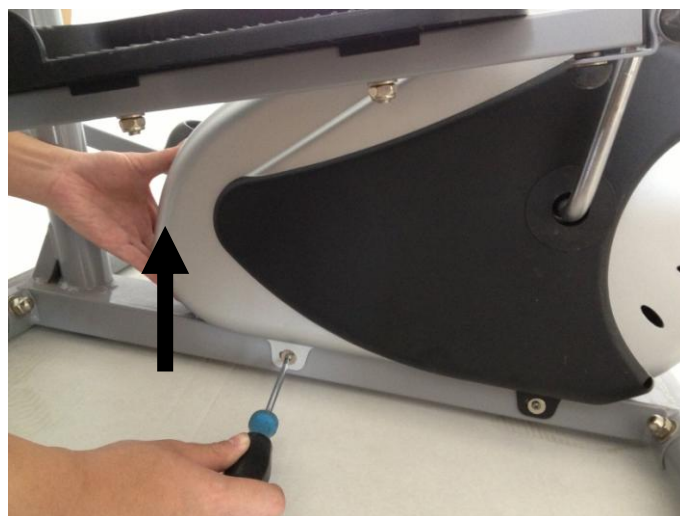

6. If it is very hard to pedal on the higher tension levels, or you hear rubbing noises, please remove the chain cover, and adjust the screw seen in the following diagram. You will need to lower the position of the screw by turning counter-clockwise; this will keep the magnet board from contacting the magnetic flywheel. Before re-installing the chain cover, test the tension level 8 to ensure the magnets do not touch the flywheel.

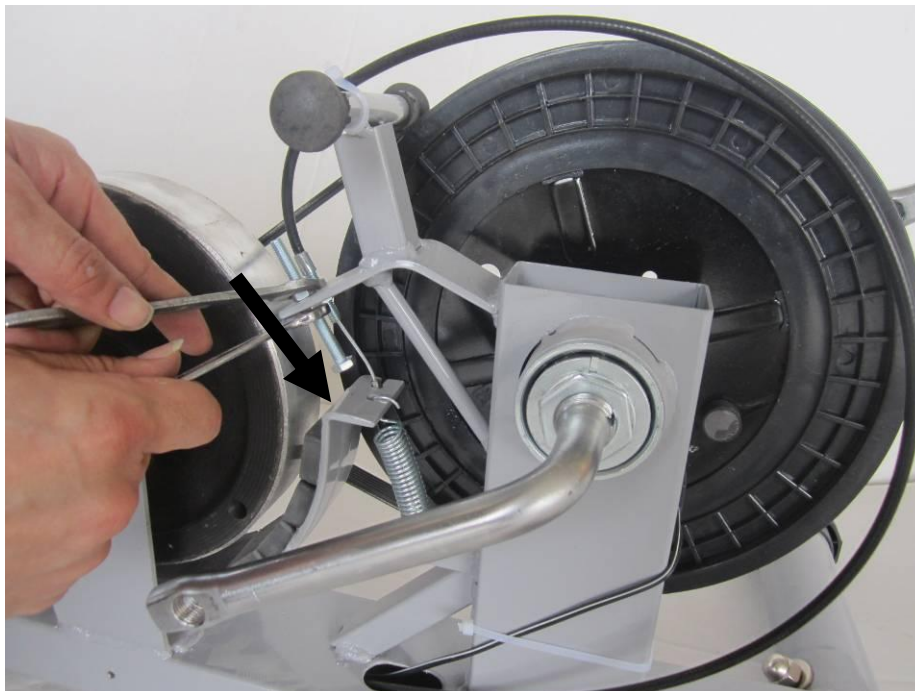

7. If you still hear noises after you did Step 5 and Step 6, please remove the chain cover; loosen the screws for the flywheel about a half of a rotation. See the following diagram.

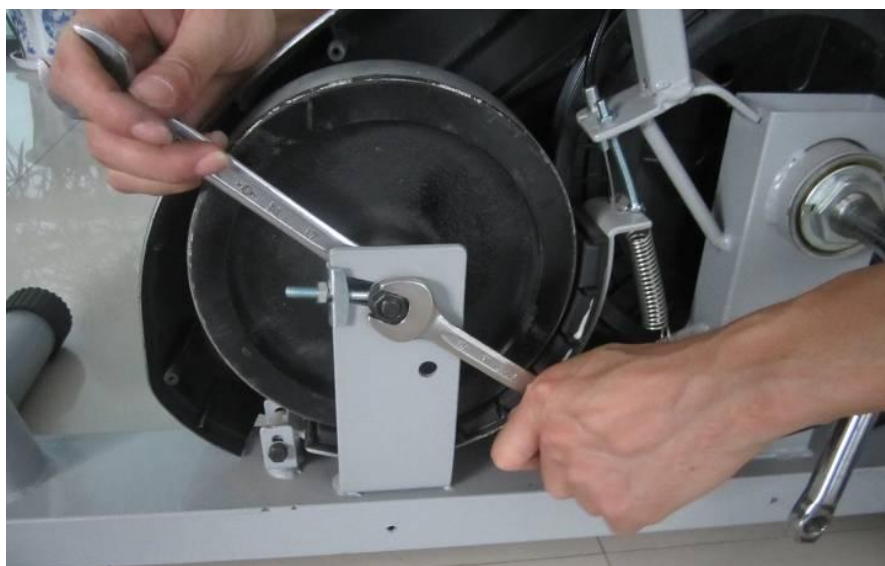

8. If you feel the machine is uneven, please adjust the Leveler Cap (5) on Real Stabilizer (3) by turning it. If the machine is wobbly when you use it, please consider adding an exercise mat under it