

VEHICLE BODY STYLE GROUP DIAGRAM

BEFORE INSTALLATION: Check your vehicle's body metal (rocker panel) underneath to determine which group your vehicle's body belongs to. (Refer to the application chart on the following page). Follow the group instructions for your vehicle only.

* For applications that require drilling, please see page 11.

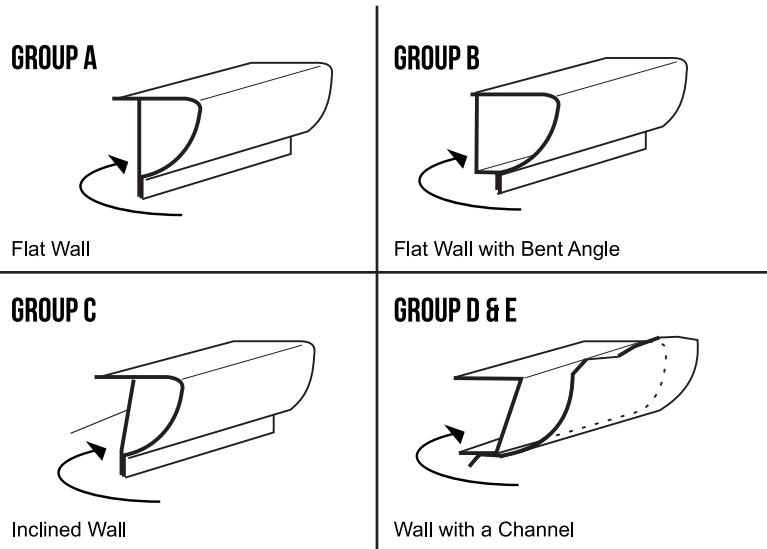

WARNING :

- * Before you start installing, read these instructions completely and make sure you understand them.
- * Do not install this product on your vehicle if the vehicle's body metal is rusted or otherwise damaged.
- * Before drilling any holes, be sure the area is clear of any obstacles, such as fuel lines, brake lines, wire harnesses, A/C lines, etc. Be careful not to damage the painted body area.
- * Do not modify step or installation hardware. Use step only on vehicles listed on application chart. Install aluminum steps following these instructions only.
- * Use steps to enter and exit vehicle only.

IMPORTANT: Bully assumes no liability for any damage or injury caused by customer's failure to adhere to the warnings and the directions in these instructions.

TOOLS NEEDED:

- Phillips screw driver #2 (both long and short)
- Power drill, drill bits (1/8", 1/4", 3/8")
- Center punch
- Open end wrench
- Ratchet with socket
- Small round file
- Black marker

NOTE: AS - 600S, AND AS - 600SB CONTAINS PIECE COUNT FOR ONE STEP. TWO STEPS WILL INCLUDE 2X THE PIECES.

MOUNTING HARDWARE LIST FOR ONE STEP:

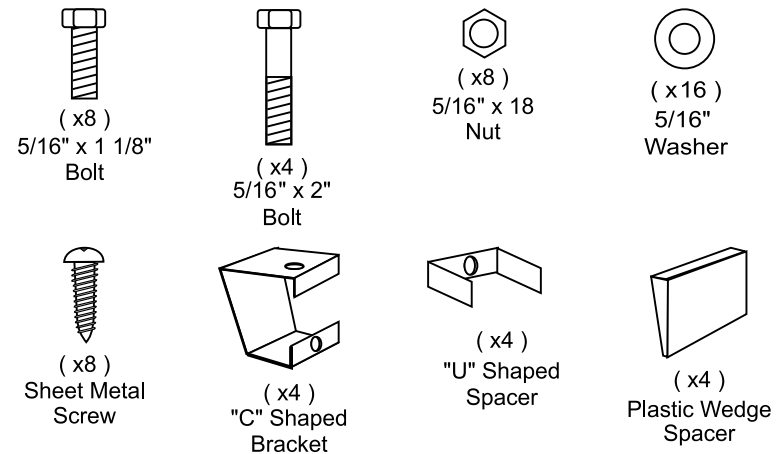

MOUNTING HARDWARE FOR RAM 09-18 MODELS ONLY:

NOTE: Drilling required. Follow the drilling instructions on page 11.

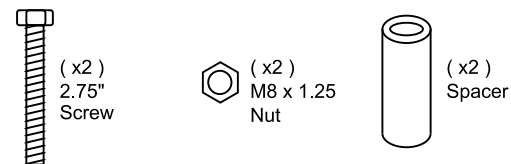

INSTALLATION INSTRUCTIONS FOR GROUP A, B, C :

1. Find a proper position to mount the step. NOTE: For correct placement, the center of the step should be in line with the front edge of the seat's frame, also the step's mounting plate should be able to lay flat against the vehicle's rocker panel.
2. With the step in place, mark a vertical line along the center of the step onto the pinch weld flange of the rocker panel. Note: Some truck models may need this flange to be bent into a vertical position (see detail on Fig. A inserted diagram). Measure 4 1/16" out on each side of the marked line and mark these points on the pinch weld flange. The distance between the two outside lines should be 8 1/8".
3. Drill a 3/8" hole on these points. Before drilling make sure you center the 3/8" drill bit on the flange, use a center punch and 1/8" drill bit to drill a pilot hole for best results. Important: Make sure the area where you will be drilling is free and clear of all obstructions (wires, fuel lines, etc).
4. Place the step into its mounting position, push the step up as far as it will go so the bottom of the mounting plate is even with the bottom of the pinch weld. Make sure the step is level and mark a point on each of the step's two legs through the 3/8" holes just drilled.
5. Remove the step and use a 3/8" drill bit to drill a hole on marked points on the step.
6. FOR GROUP A: (See Fig. A)
 - a. Mount the step onto the vehicle, using 5/16" x 1 1/8" bolts, nuts and washers, and hand tighten for now (see Fig. A).
 - b. Using the 1/8" drill bit, drill a hole through the body metal using the top 1/4" hole on the step as a guide. Install and tighten 1" sheet metal screw in the upper holes. Now tighten all the previously installed bolts to complete the installation.
7. FOR GROUP B: (See Fig. B)
 - a. Mount the step to the vehicle using the 5/16" x 2" bolts, nuts and washers, insert the "U" shaped spacers as shown in (Fig. B) through the hole on the pinch weld flange. Hand tighten for now.
 - b. Using the 1/8" drill bit, drill a hole through the body metal using the top 1/4" hole on the step as a guide. Install and tighten 1" sheet metal screw in the upper hole. Now tighten all the previously installed bolts to complete the installation.
8. FOR GROUP C: (See Fig. C)
 - a. Mount the step to the vehicle using the 5/16" x 1 1/8" bolts, nuts and washers, leave hand loose for now. Place the two plastic wedges between the upper portion of the step and body metal (see Fig. C).
 - b. Move the wedges up and down until the step is level through the 1/4" hole on the step, make a mark on each wedge while holding the step in place. Remove the wedges, drill a 1/4" hole the marked points.
 - c. Place the wedges back into place, drill a 1/8" hole through the step and the wedge to the body metal, use the 1" sheet metal screws to tighten the step, wedge and body metal together. Now tighten all the previously installed bolts to complete the installation.

FIGURE A

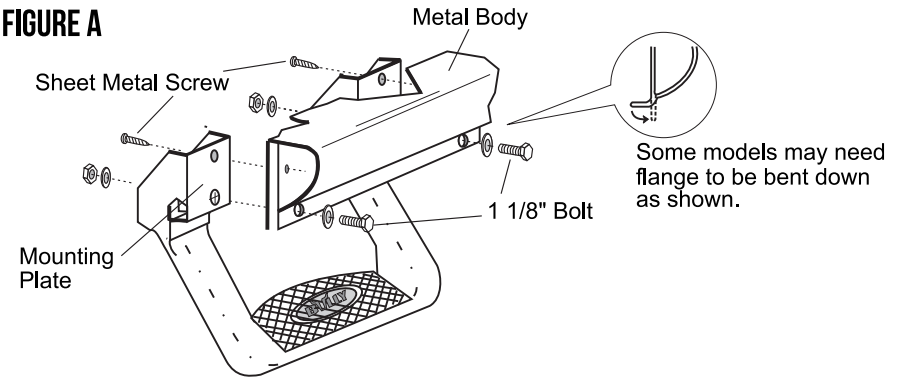

FIGURE B

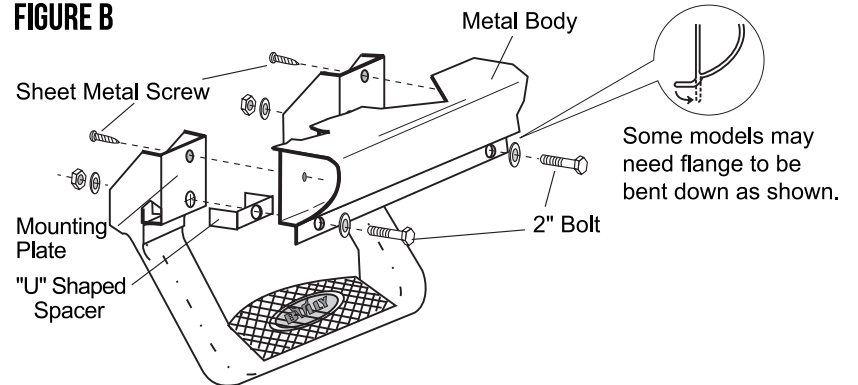
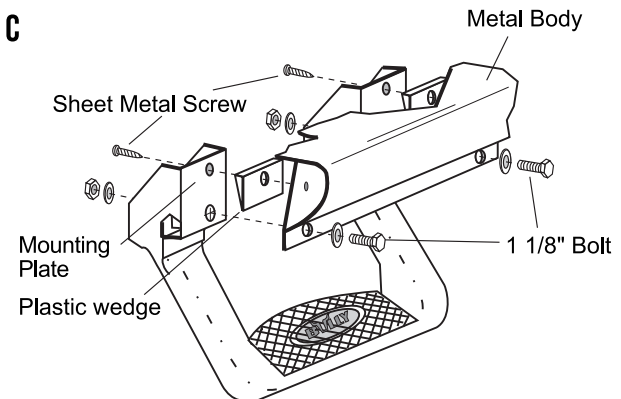
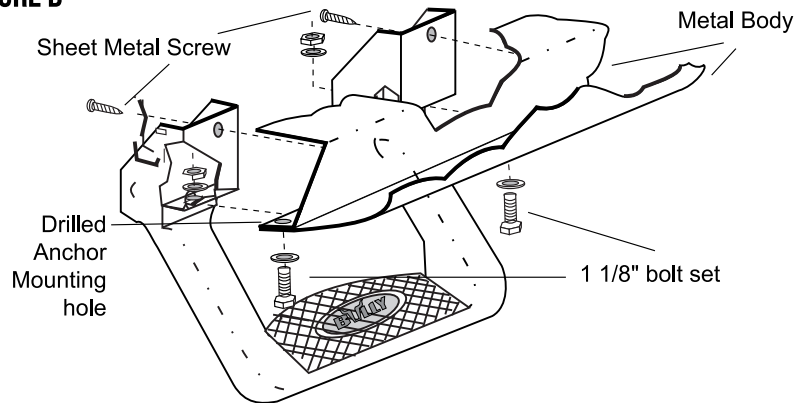

FIGURE C



INSTALLATION INSTRUCTIONS GROUP D:

1. Find the proper position to mount the step. NOTE: For correct placement, the center of the step should be in line with the front edge of the seat's frame, also the step's mounting plate should be able to lay flat against the vehicle's rocker panel.
2. With the step in place, mark a vertical line along the center of the step onto the pinch weld flange of the rocker panel. Measure 4 1/16" out on each side of the marked line and mark these points on the pinch weld flange. The distance between the two outside lines should be 8 1/8".
3. Drill a 3/8" hole on these points. Before drilling the 3/8" hole on the flange, use a center punch and 1/8" drill bit to drill a pilot hole for best results. Important: Make sure the area where you will be drilling is free and clear of all obstructions. (Wires, fuel lines, brake lines, etc.)
4. Align the mounting holes of the step with the holes (3/8") that were just drilled on the flange. Using the 5/16" x 1 1/8" bolts, nuts and washers, mount the step to the body and hand tighten for now (see Fig. D). If the 1 1/8" bolts do not go in flush, you may need to use a small round file to file the opening.
5. Using the 1/8" drill bit, drill a hole through the body metal using the top 1/4" hole on the step as a guide. Install and tighten 1" sheet metal screws in the upper holes. Now tighten all other previously installed bolts to complete the installation.

FIGURE D**INSTALLATION INSTRUCTIONS GROUP E:**

1. Review the diagrams of Group E on the following page (see E-2 & E-4) for proper application.
2. If the mounting plate does not reach the rocker panel, the supplied "C" bracket should be used to perform this procedure.
3. With the step in place, mark a vertical line along the center of the step onto the pinch weld flange of the rocker panel. Measure 4 1/16" out on each side of the marked line and mark these points on the pinch weld flange. The distance between the two outside lines should be 8 1/8".
4. Along the outside lines, measure 1/2" (measure 1/4" for Suburban) inward from the inside edge of the pinch weld and mark a point on each of the two lines. For best results, use a center punch with 1/8" drill bit to drill pilot holes. Then drill a 3/8" hole at these two points. Important: Make sure the area where you will be drilling is free and clear of all obstructions (i.e. Air Conditioning Lines & Wire harnesses) see Fig. E-3 & E-4 for review.
5. Place the "C" shaped bracket up inside the rocker panel (see Fig. E-1 & E-3), carefully maneuver the brackets into the required position. Mark a point onto the "C" bracket through the 3/8" hole just drilled on the pinch weld flange, remove the bracket and drill a 3/8" hole at the marked point.
6. Attach the "C" brackets to the step, using 1" sheet metal screws through the top holes on the step and the small holes on the "C" brackets. Make sure that the brackets are lined up with the edges of the step. Note: If the bottom hole of the "C" bracket does not line up, just bend the bracket inward until the bottom hole is centered about 3/8" up onto the step. Mark a point onto the step through the lower hole on the brackets. Remove the brackets from the step, check the distance between two marked points on the step, the measurement should be 8 1/8".
7. Drill a 3/8" hole through the marked points on the step.
8. Maneuver the "C" brackets back into their mounting position. Insert the 5/16" bolt with washer through the 3/8" holes on the pinch weld (see #1 on Fig. E-2). Note: If the holes do not line up flush, file the holes so that the bolt can pass the body metal and the bracket freely. Do not tighten the bolts yet, hold the bracket firmly in place and mark a point on the vehicle's body metal through the top hole on the "C" bracket. Remove the "C" brackets from their mounting position.
9. Refer to Fig. E-5, remove the plastic door entry cover, move the wire harness out of the way for drilling.
10. Drill a 1/8" hole through the points on the body of metal that were just marked in step #8. Make sure all wires are out of the way.

11. Install the "C" brackets back into the mounting position. Insert sheet metal screws through the top holes and tighten, insert the 5/16" bolts through the bottom holes to hold on t the brackets to the vehicle. Add washers and nuts, do not tighten down yet. (see Fig. E-2, E-4).
12. Attach the step to the brackets. Insert the sheet metal screws through the upper holes on the "C" brackets, and tighten, install 5/16" bolts, washers and nuts through the lower holes to secure the step to the brackets. Now tighten all the screws, bolts and Nuts firmly (see Fig. E-2 & E-4).
13. To complete the installation, install the plastic door entry cover, making sure the screws will not pierce any wires when putting harness back in place.

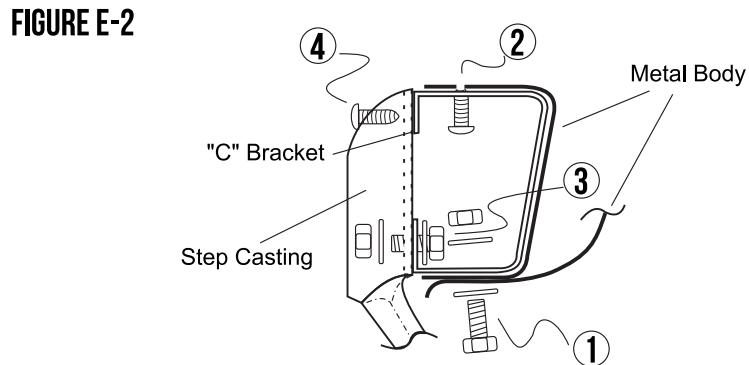
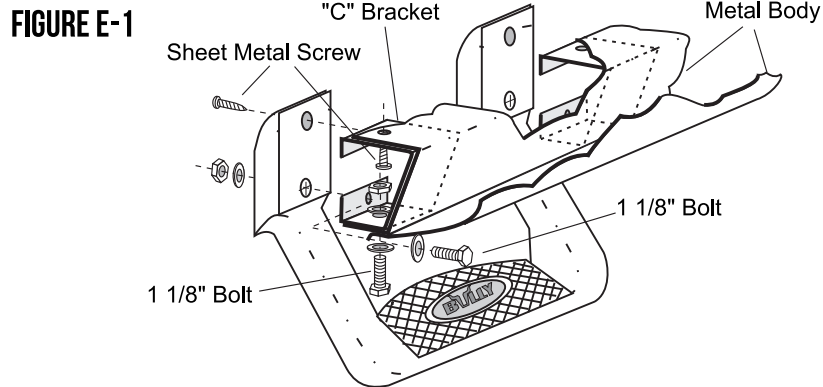

FIGURE E-3

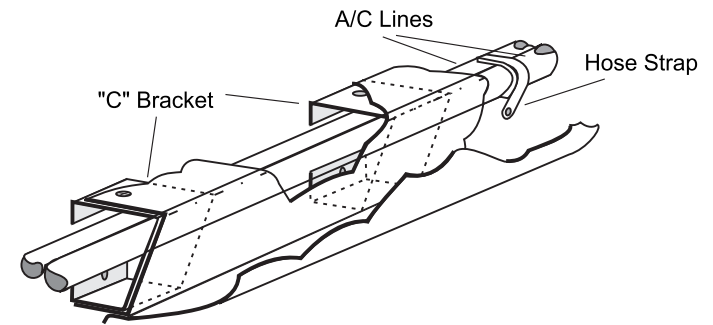

FIGURE E-4

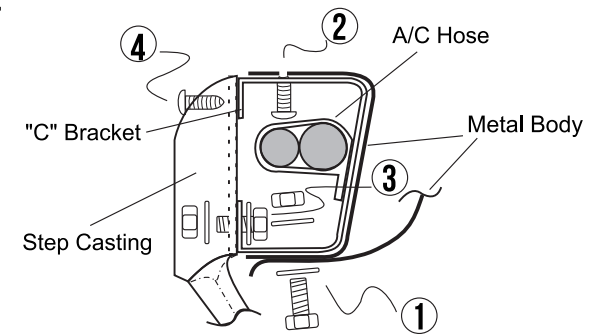
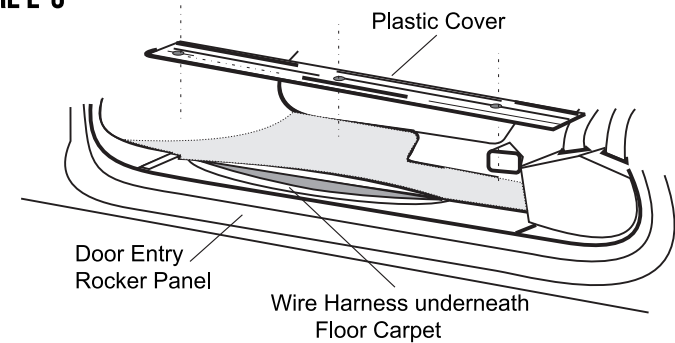
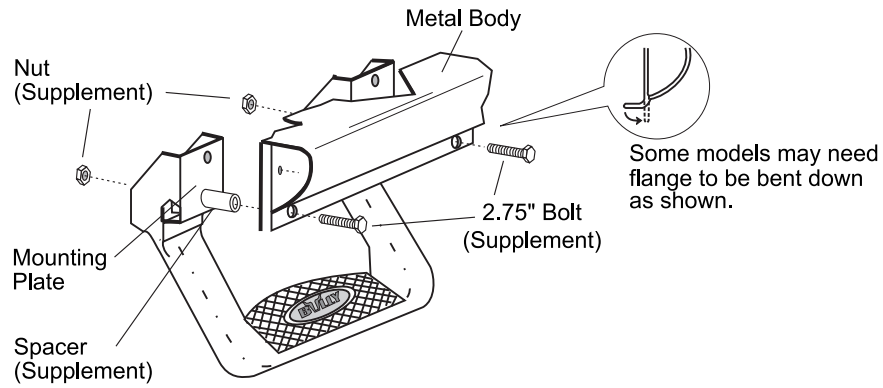

FIGURE E-5



INSTALLATION INSTRUCTIONS FOR RAM 09-18 MODELS ONLY :

NOTE: Drilling required. Follow the drilling instructions on page 11.



Some models may need flange to be bent down as shown.

FOR APPLICATIONS THAT REQUIRE HOLE TO BE DRILLED

1. Measure 2" from the bottom of the hole already drilled out and 1 1/16" from the edge and mark the spot.
2. Drill out the hole using a 11/32" drill bit.
3. Verify supplied screw fits thru the hole.

