

Oster



Ingredients In. Guesswork Out.
Pre-Programmed Cycles For Perfect Results

Oster

WARNING: PLACING YOUR HANDS
NEAR TO OR ON THE BLENDER
DURING OPERATION CAN CAUSE
SERIOUS INJURY.

Drinks
Food
Recipes
Favorites

HELP

In2itive™

Blender/Food Processor with LCD Screen

User Manual

6710

IMPORTANT SAFEGUARDS

When using your blender, you should always follow basic safety precautions, including the following:

- Read all instructions before use.
- To protect against electrical hazards, do not immerse the cord, plug or motor base in water or other liquids.
- Always use the product on a clean, flat, hard, dry surface. There should be no material such as a tablecloth or plastic between the unit and surface.
- Avoid contact with moving parts.
- Keep hands and utensils out of jar while blending to reduce the risk of:
 - Severe personal injury
 - Damage to the blender
- If scraping is necessary, turn the power OFF and use a rubber spatula only.
- Do not use the appliance:
 - With a damaged cord or plug
 - After the unit fails to work correctly
 - After you drop or damage the product in any wayReturn the product to your nearest Authorized Oster® Appliance Service Center for a safety check, adjustment or repair.
- Triple blades are sharp. Handle them carefully.
- To reduce the risk of injury:
 - Do not leave the triple blades sitting out or exposed
 - Always completely assemble the blades to the jar before putting on the base
- Always put the lid on the jar before operating the blender.
- When blending hot liquids beware of steam. Remove the feeder cap from the lid to allow steam to escape.
- Do not use outdoors.
- Do not allow the cord to touch hot surfaces or hang over the edge of a table or counter.
- Unplug the blender when it is not in use, before taking off or putting on parts and before cleaning.
- Never leave the appliance unattended while it is running.
- You risk personal injury, fire or electric shock if you use attachments, jars or parts other than those recommended by Oster®.
- Supervise children closely when they use or are nearby appliances.

SAVE THESE INSTRUCTIONS

- This product is for household use only.
- The maximum rating marked on the product is based on the attachment that draws the greatest load. Other attachments may draw less power.

Power Cord Instructions

Please follow the instructions below to ensure the safe use of the power cord.

- This blender has a power cord storage area that allows you to adjust the length of the cord so that it is the appropriate length for your location. Try to position the blender near the power source to reduce the hazards associated with power cords (such as becoming entangled or tripping over a long power cord).
- For blenders purchased in the U.S. and Canada: this appliance has a polarized plug (one prong is wider than the other). To reduce the risk of electric shock, this plug will fit into a polarized outlet in only one direction. If you cannot completely insert the power plug into the power outlet, reverse the direction of the plug. If it still does not fit, contact a qualified electrician. Do not modify the plug in any way.
- Do not pull, twist or otherwise abuse the power cord.
- Do not wrap the power cord around the main body of the blender during or after use.



This symbol has been placed in specific areas of the User Guide portion of this book. Its purpose is to help you easily identify instructions that require your special attention.

Welcome	1
Learning about your Product	2
Using your Product	4
Assembly	4
Set Up	5
When to Use a HELP Screen	6
What are ERROR Messages?	6
Using the AUTOMATIC Recipe Programs (for Drinks or Food)	7
Using the AUTOMATIC Favorites Program	9
Using the Ice Crush Function	10
Using the AUTOMATIC Food Program	11
Using the AUTOMATIC Drinks Program	12
Overriding the AUTOMATIC Programming	13
Using MANUALLY	16
Using the Low and High Buttons	17
Using the Pulse Button	18
After Use	19
Caring for your Product	20
Cleaning	20
Checking the Triple Blades	20
Storing	21
Servicing	21
Blending Tips	22
Liquids	22
Using the Feeder Cap	22
Hot Foods	23
Ingredients Quantity	23
Foods Chart	24
Recipes	26
Frozen Drinks	26
Milk Shakes	28
Powder Drinks	29
Smoothies	30
Salsa	33
Soups	35
Baby Food	37
Batter	39
Nuts/Crumbs	40
Accessory	42
Blend-N-Go™ Cup	42
Two-year Limited Warranty	43
How to Obtain Warranty Service	44

Congratulations on your purchase of an Oster® Model 6710 In2itive™ Blender/Food Processor. Your product includes the following technology and features:

- An **“In2itive”** technology takes the guesswork out of blending, giving you the ability to make a variety of foods and drinks with consistent results every time.
- A **user-friendly touchpad** design walks you through the complete process, whether you use the pre-programmed **AUTOMATIC** LCD settings, the recipe section in the instructions or your own recipes.
- A **triple set of blades** optimizes programmed food and drink preparation.
- A **dynamic breaking function** stops the blades quickly once the cycle is complete, ensuring that the ingredients are not over processed.
- A **500-watt reversible motor** keeps ingredients near the blades by spinning at low speeds as needed then gradually speeding up to the programmed level, ensuring optimum results from smooth to chunky.
- **MANUAL** controls allow you to add additional time at the end of **AUTOMATIC** programs or allow you to operate the product **MANUALLY** for personal recipes.
- A **Progress** indicator lets you estimate how much more programmed time remains.
- A **Pause/Resume** button lets you stop to add additional ingredients, then resume at the same point to complete the **AUTOMATIC** program.
- A **feeder cap** lets you add ingredients without removing the jar lid.

- 1. Feeder Cap** – Allows you to add ingredients during use.
- 2. Lid** – Seals the blender jar.
- 3. Jar** – Made from Polycarbonate, a virtually indestructible plastic. Has a maximum capacity of 6 cups.
- 4. Sealing Ring** – Seals the jar to the triple blade assembly.
- 5. Triple Blades** – Creates a forward and reverse action when using the **AUTOMATIC** programs.
- 6. Low Profile Base** – Holds the jar securely in 6 positions. Contains a powerful, reversible, variable speed motor. It uses programmed logic that takes the guesswork out of creating foods and drinks.
- 7. Control Panel** – Contains all the necessary controls to operate your product.

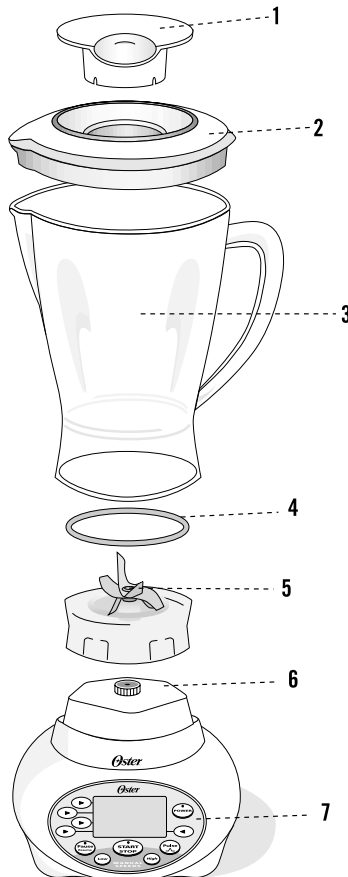

- 8. **POWER Button** – Turns the product **On** and **Off**.
- 9. **LCD Screen** – Displays user prompts for food or drink selections and recipes.
- 10. **Pulse Button** – Press and hold to **Pulse**. Release the button to Stop.
- 11. **High Button** – Use to **MANUALLY increase** speed.
- 12. **START/STOP Button** – Use to Start and Stop the product.
- 13. **Low Button** – Use to **MANUALLY decrease** speed.
- 14. **Pause/Resume Button** – Use to **Pause** and **Resume** the **AUTOMATIC** or **MANUAL** function.
- 15. **Touchpad Buttons** – Use to navigate through programmed menus and screens.

Control Panel

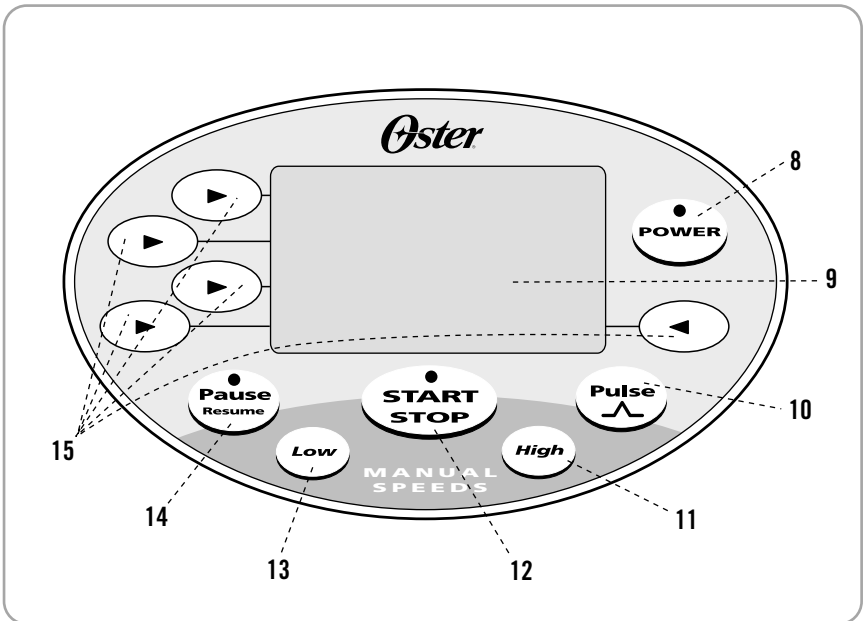

Before you use the product for the first time, separate the lid, feeder cap and blades from the jar. Wash in warm, soapy water. Rinse and dry well.

Assembly

- 1 Check to ensure the sealing ring is properly seated on the ledge surrounding the triple blades.
- 2 Turn the jar upside down.



- 3 Turn the triple blades upside down and twist them into the bottom of the jar. You can use the feeder cap as a tool to twist the blades securely in place.



Be sure the triple blades are locked securely to the jar before using.

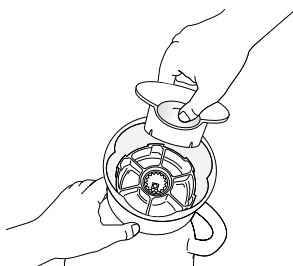

- 4 Wrap the power cord around the cord storage area on the base of the product until the cord is the length you desire.

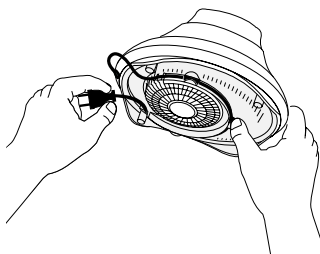

- 5 Set the jar onto the base.
- 6 Plug the power cord into a standard household 120/127-volt, 60 Hz. AC outlet. You are now ready to start.

Set Up

- 1 Press the **POWER** button. All the lights blink on briefly and you will hear a greeting sound as the **Welcome** screen appears. The **POWER** light stays on, meaning the product is ready to use. Each time you press one of the buttons, you will hear a tick sound.

If you do not have the jar or another attachment placed on the base, a screen will ask you to put one in place.

Next, **Tutorial** screens appear briefly explaining the different functions of the touchpad and **MANUAL** buttons. Follow the instructions on these screens.

- 2 Press the arrow button beside the blinking **NEXT** to page through the tutorial screens.
- 3 To skip the **Tutorial** screens in the future, press the button beside the arrow on the screen. If you want to view the tutorial every time you turn on the product, press the arrow button beside the blinking **NEXT**.

Cont'd. next page

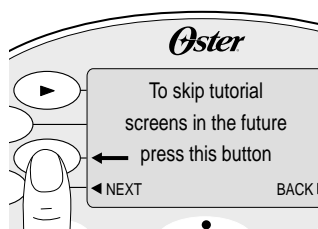

- 4 To enter the **MAIN MENU** for **AUTOMATIC** programs, press the arrow button beside the blinking **NEXT**.

Make your selections at the **MAIN MENU**. To change the introduction screens, press the arrow button next to **HELP**.

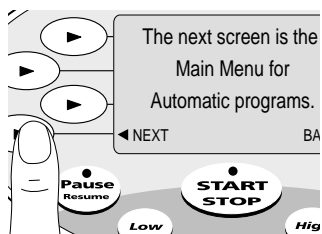

When to Use a HELP Screen

HELP screens are useful to:

- Revisit **Tutorial** screens,
- Turn the **Tutorial** screens **On** or **Off**,
- Turn the audible button tick sounds, **On** or **Off**,
- Display your **Favorites** list first (vs. **MAIN MENU**) when the product is turned **On**.

What are ERROR Messages?

These are programmed messages that appear when you press an unrecognized button, asking if you want to:

- End your program?
- Exit **AUTO** Programming and use **MANUAL** controls?

Or stating that:

- Certain buttons work only for **MANUAL** speeds,
- Product is about to leave **Pause** mode and exit the program,
- Product is shutting down.

When these messages appear, follow the instructions displayed on the screen.

Using the AUTOMATIC Recipe Programs (for Drinks or Food)

1 From the **MAIN MENU**, press the arrow button next to **Recipes**.

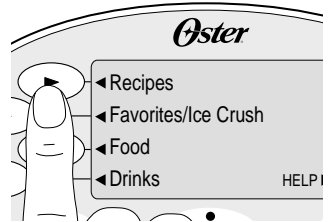

2 Select from the programmed **Drink** recipes or **Food** recipes.

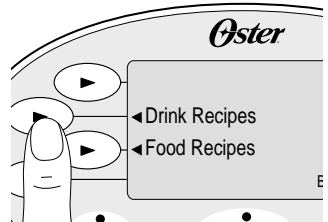

3 Select a recipe category.

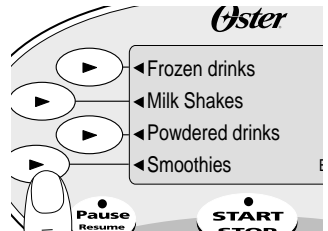

4 Select a specific recipe.

Cont'd. next page

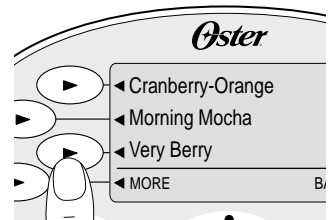

- 5 Add the ingredients exactly as shown on the screen.



- 6 Press the arrow button beside the flashing **NEXT** for additional screens of ingredients or to advance to the **Press Start** screen.

At the **Press Start** screen, the light on the **START/STOP** button blinks, indicating that the product is ready to begin processing. Arrow buttons beside **MAIN MENU** and **BACK** returns you to the **MAIN MENU** if you want to start over, or to the previous screen.



- 7 Make sure the lid and feeder cap are on and press the **START/STOP** button to start. The light on the button stays on and the **Progress** indicator bar represents the time left in the program.

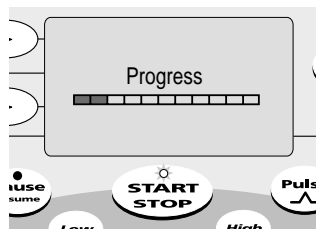

When complete, the product stops **AUTOMATICALLY**, you will hear a series of tones, and **ENJOY!** shows on the screen. For additional controls, see **Overriding the AUTOMATIC Programming** on page 13–14.



If the jar is ever removed from the base while the product is running, the motor will stop as quickly as possible and error tones will sound.

Using the AUTOMATIC Favorites Program

1 From the **MAIN MENU**, press the arrow button next to **Favorites/Ice Crush**. **Favorites** are shortcuts to the **last three** items you processed. **Favorites** may include recipe selections. The **Favorites** screen can be set as the default start up screen by pressing **HELP** at the **MAIN MENU**.

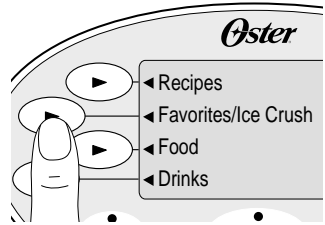

2 Select a **Favorite**.

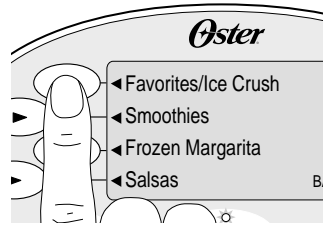

The light on the **START/STOP** button blinks. Add the ingredients or follow the recipe and make sure the lid and feeder cap are on. Arrow buttons beside **MAIN MENU** and **BACK** returns you to the **MAIN MENU** or to the previous screen.



3 Press the **START/STOP** button to start. The light on the button stays on. The **Progress** indicator bar monitors the status.

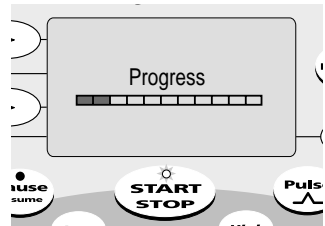

When complete, the product stops **AUTOMATICALLY**, you will hear a series of tones, and **ENJOY!** shows on the screen. For additional controls, see *Overriding the AUTOMATIC Programming* on pages 13–14.

Using the Ice Crush Function

- 1 From the **MAIN MENU**, press the arrow button next to **Favorites/Ice Crush**.

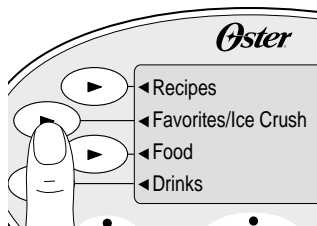

- 2 Select **Ice Crush**. **BACK** returns you to the **MAIN MENU**.

The light on the **START/STOP** button blinks.

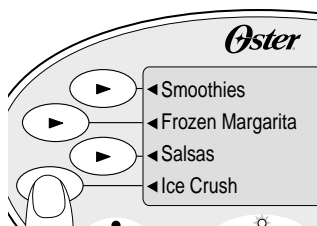

- 3 Add ice and secure the lid or feeder cap.
4. Press the **START/STOP** button or hold in the **Pulse** button to begin. An arrow button beside **MAIN MENU** returns you to the **MAIN MENU**.

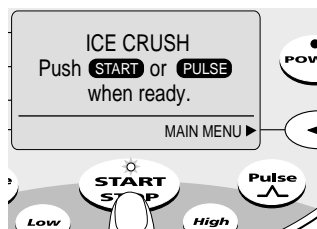

- 5 When the ice is crushed, press the **START/STOP** button or release the **Pulse** button.

 *The product will stop automatically after 2 minutes.*

- 6 When you finish, press the **POWER** button to turn the product off.

Using the AUTOMATIC Food Program

- 1 From the **MAIN MENU**, press the arrow button beside **Food**.
- 2 Select a food category. The arrow button beside **MORE** takes you to additional food categories.

The light on the **START/STOP** button blinks.

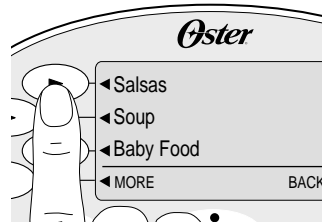

- 3 Choose a recipe from the recipe section of this manual or use one of your own.
- 4 Add the ingredients to your liking and make sure the lid and feeder cap are on. Arrow buttons beside **MAIN MENU** and **BACK** returns you to the **MAIN MENU** or to the previous screen.



- 5 Press the **START/STOP** button to start. The light on the button stays on. The **Progress** indicator bar monitors the status.

When complete, the product stops **AUTOMATICALLY**, you will hear a series of tones, and **ENJOY!** shows on the screen. For additional controls, see **Overriding the AUTOMATIC Programming** on pages 13–14.

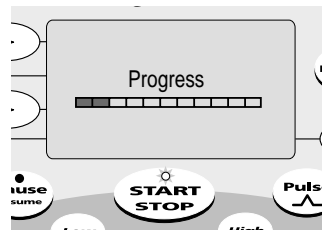

Using the AUTOMATIC Drinks Program

- 1 From the **MAIN MENU**, press the arrow button beside **Drinks**.

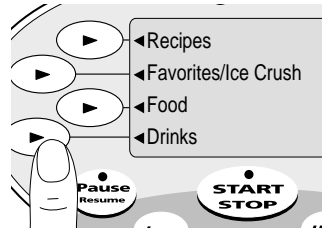

- 2 Select a drink category.

The light on the **START/STOP** button blinks.

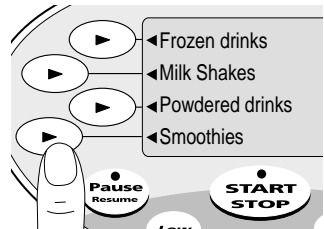

- 3 Choose a recipe from the recipe section of this manual or use one of your own.

- 4 Add the ingredients to your liking and make sure the lid and feeder cap are on. Arrow buttons beside **MAIN MENU** and **BACK** returns you to the **MAIN MENU** or to the previous screen.



- 5 Press the **START/STOP** button to start. The light on the button stays on and a **Progress** indicator bar monitors the status.

When complete, the product stops **AUTOMATICALLY**, you will hear a series of tones, and **ENJOY!** shows on the screen. For additional controls, see *Overriding the AUTOMATIC Programming* on page 13–14.

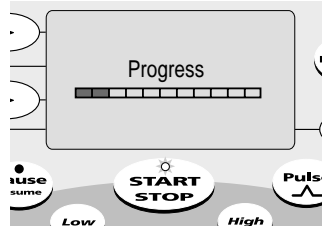

Overriding the AUTOMATIC Programming

Pause

- 1 To **Pause** and add more ingredients, while a program is in progress, press the **Pause/Resume** button. The product will stop and the **Pause/Resume** light blinks. A screen shows that the **AUTOMATIC** program is paused.

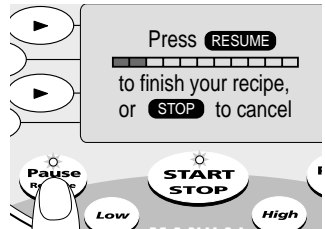

- 2 Remove the feeder cap or lid to add the additional ingredients.
- 3 Secure the feeder cap or lid.
- 4 Press the **Pause/Resume** button to finish the **AUTOMATIC** program. The **Pause/Resume** button light turns off and the **PROGRESS** indicator continues growing.

Cont'd. next page

- 5 If you **Pause** for longer than 1 minute, a warning tone will sound and a **Pause** termination warning screen will appear for 10 seconds, telling you the product is about to exit the program. You can choose to **KEEP WAITING**. Doing nothing or pressing the arrow button next to **OK** returns you to the **MAIN MENU**.
- 6 To cancel **Pause** or the **AUTOMATIC** program, press the **START/STOP** button, then press the arrow button beside **YES** to return to the **MAIN MENU** or press the arrow button beside **NO** to resume.

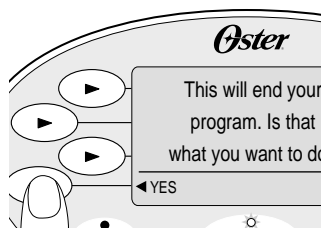

- 7 Once the program is finished, you will hear a tone as the product **AUTOMATICALLY** stops. The **Progress** indicator will flash for about 20 seconds. You will then hear a tone and the product will exit the program returning to the ready state.

Pulse

- 8 While the **Progress** indicator flashes and before the second tone, you can process ingredients longer by pressing and holding in the **Pulse** button. During **Pulse** a single **Progress** indicator segment "runs" from left to right. Be careful you do not over-process your food or drinks.

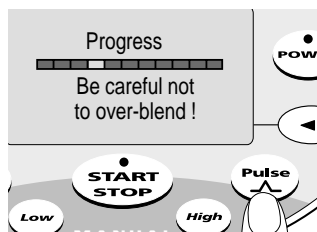

- 9 Release the **Pulse** button when you are done. The **Progress** indicator bar will again flash for about 20 seconds before resetting the product. You can continue **Pulsing** by pressing and holding in the **Pulse** button while the **Progress** bar is flashing.
- 10 If you do not press **Pulse**, the product will return to the ready state.
- 11 Press the arrow button next to **MAIN MENU** or wait about 20 seconds to return to the **MAIN MENU**.
- 12 Press the **POWER** button to turn the product off. After sitting idle for 30 minutes, a screen appears telling you the product will shut down. You can choose to **KEEP WAITING**. Doing nothing, or pressing the arrow button next to **OK**, shuts the product down.



If the jar is ever removed from the base while the product is running, the motor will stop as quickly as possible and error tones will sound.

Using MANUALLY

The **MANUAL** buttons include **Low**, **High** and **Pulse**. Use these buttons for personal recipes or to add extra time to an existing recipe.

- 1 Press the **POWER** button. If necessary, navigate to the **MAIN MENU**.

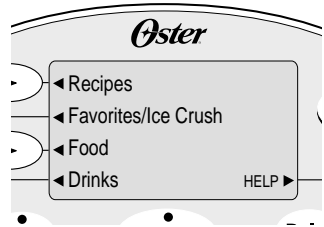

- 2 Add your ingredients.

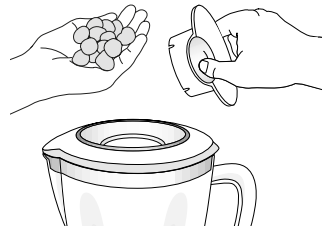

- 3 Secure the lid and feeder cap.

Cont'd next page

Using the Low and High Buttons

- 1 Press the **Low** or **High** buttons to run the product at a slower or faster speed. You will see the **START/STOP** light blink indicating that the product is ready to start.



Use lower settings for food, higher settings for drinks.

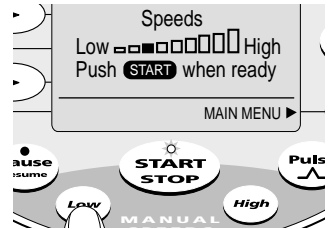

- 2 Press the **START/STOP** button to start the product. The **START/STOP** button light will change to On and the product will run at the speed shown by the **speed bar** segment.

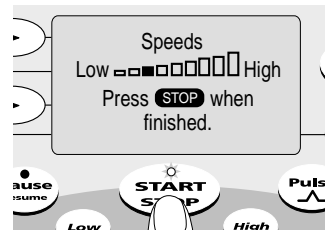

- 3 To adjust the speed while the product is running, press the **Low** or **High** buttons.
- 4 Continue to press the **Low** or **High** buttons to gradually speed up or slow down the product, as shown on the **speed bar**.

Cont'd. next page

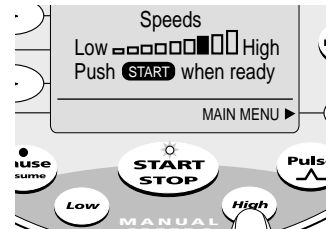

- 5 Press the **START/STOP** (or **Pause/Resume**) button when you finish. The **START/STOP** light will blink again.

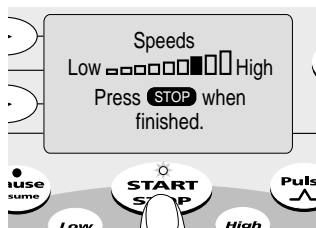

- 6 If you wish, you can press the **START/STOP** button again to continue at the same speed.

Using the Pulse Button

To **MANUALLY** run the product in short bursts use the **Pulse** button. **Pulse** only works in **MANUAL** mode or after a program has finished. **Pulse** continues from the last selected action. So, if the last action was at a **High** setting, you will now **Pulse** at **High**. If the last action was at a **Low** setting, you will now **Pulse** at **Low**.

- 1 Press and hold in the **Pulse** button. **PULSING!** flashes as the product **pulses** at your selected setting.

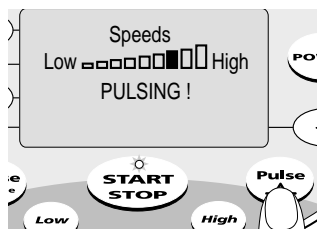

- 2 Release the **Pulse** button to stop. The **START/STOP** light will blink, indicating that the product is ready to start. If you do not use the product for 1 minute, it will reset to the ready state.
- 3 When you stop, press the arrow button next to **MAIN MENU** or wait about 20 seconds to return to the **MAIN MENU**.

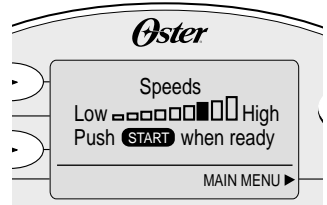

- 4 Press the **POWER** button to turn the product Off.



If the jar is ever removed from the base while the product is running, the motor will stop as quickly as possible and error tones will sound.

After Use

- 1 Lift the jar straight up from the base, remove the lid and empty the jar.
- 2 If necessary, use a rubber spatula to scrape foods away from the sides of the jar.

Cleaning

Release the triple blades from the bottom of the jar by turning counterclockwise. If necessary, use the feeder cap as a tool to help remove the triple blades. The feeder cap, lid, jar and blades are dishwasher safe. Use the top rack of the dishwasher for the feeder cap, lid and triple blades. Place sealing ring in bottom basket of dishwasher.

You can also wash the parts in warm, soapy water. Rinse well and dry. Wipe the base with a soft, damp cloth to clean. Never submerge the low profile base in a liquid.

Check the parts as you put them back together. Make sure the feeder cap and lid fit tightly on the jar.



Checking the Triple Blades

- Turn the triple blades as shown, being careful of the sharp blade edges.
- The blades should turn freely. If they are stuck or hard to turn, do not use the product.

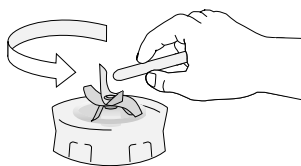

Storing

Reassemble the blender for storage.



WARNING Never put the jar, or any other parts, in a microwave oven. Never store foods or drinks in the jar.



Servicing

If repairs are needed send your appliance only to an Authorized Oster® Appliance Service Center.

Use only replacement parts from Oster.®

See *How to Obtain Warranty Service* on page 44.

Liquids

Put liquids into the jar first, unless the recipe says otherwise.



Using the Feeder Cap

Do not remove the lid while in use. Food may splatter if you do. Instead, open the feeder cap to add smaller ingredients



Hot Foods



WARNING When you work with **HOT FOODS**, remove the feeder cap to vent steam. Tilt the cap away from you partially covering the opening. Keep hands and other exposed skin away from the lid opening to prevent possible burns.



When you work with **HOT LIQUIDS**, remove the feeder cap and start at a Low speed, and then gradually increase to a faster speed. Do not add liquid over the 4 cup (1L) level. Always keep hands away from steam.

Ingredients Quantity

Use only the amount of food suggested in the recipes. If you want greater amounts, prepare in batches. Using larger amounts may overload and strain the motor. You might also get different results from those described.

Basic ingredients processing chart for professional results

FOOD	QUANTITY
Almonds, whole	1/2 cup
Apricots, dried	1 cup + 1 Tbs. flour or sugar
Apple	1 medium, cut into 4 pcs.
Basil leaves, fresh	1 cup, packed, tough stems removed
Breadcrumbs, hard or soft	2-3 slices bread; by hand, tear into jar
Cabbage, green/red	1/4 medium head, cut into 4 pcs.
Carrot	1 large, cut into 6 pcs.
Celery	1 stalk, cut into 4 pcs.
Cilantro/fresh Coriander	1 cup, packed
Cheese, Parmesan or Romano	4 oz.; by hand, break into jar
Citrus Peel (lemon, lime, orange)	Peel of 1 large fruit + 1 Tbs. flour or sugar
Coconut	1 chunk, about 2 oz.
Cookies/Crackers, except Gingersnaps	18 - 20
Coffee Beans	1 cup
Cranberries, fresh or frozen	1 cup
Cranberries or Cherries, dried	1 cup + 1 Tbs. flour or sugar
Cucumbers or Zucchini	1 medium, cut into 8 pcs.
Dill, fresh	1 cup, packed
Garlic, peeled	5 medium cloves
Gingersnap cookies	12 - 14; by hand, break into jar
Onion, white, red or yellow	1/2 large, cut into 2 pcs.
Parsley, fresh, curly or Italian	1 cup packed
Peanuts, oil roasted	1 cup
Peanuts, dry roasted	1 cup
Pecans, halves	1/2 cup
Peppers, bell	1 medium, cut into 4 pcs.
Peppers, chilies	2 - 3 small or 1 large, cut into 4 pcs.
Raisins	1 cup + 1 Tbs. flour or sugar
Tomatoes, regular	1 large, seeded, cut into 6 - 8 pcs.
Tomatoes, plum	1 large, seeded, cut into 4 pcs.
Walnuts, halves	1 cup

SETTING	PROCESSED QUANTITY
Nuts/Crumbs program	1/2 cup
Pulse/High speed	1 cup
Pulse/High speed	1 cup
Pulse/High speed	1/2 cup
Nuts/Crumbs program	about 1/3 cup
Pulse/High speed	2 cups
Pulse/High speed	1 cup
Pulse/High speed	1/3 cup
Pulse/High speed	1/3 cup
High speed 30 sec., then Pulse/High	1 cup
High speed 15 sec., then Pulse/High	3 - 4 Tbs.
Pulse/High speed	1/4 cup
Nuts/Crumbs program	about 1 cup
High speed 15 sec., then Pulse/High	1 cup
Pulse/High speed	1 cup
Medium speed, 10 - 15 sec., then Pulse	1 cup
Pulse/Medium speed	1 cup
Pulse/High speed	1/2 cup
Pulse/High speed	about 1 Tbs.
Nuts/Crumbs program	3/4 cup
Pulse/High speed	about 1 cup
Pulse/High speed	about 1 cup
Nuts/Crumbs program	1/3 cup
Nuts/Crumbs program	1 cup
Nuts/Crumbs program	1/2 cup
Pulse/Medium speed	1 cup
Pulse/Medium speed	1 cup
High speed	1/2 cup
Pulse/Medium speed	1 cup
Pulse/Medium speed	1 1/4 cups
Nuts/Crumbs program	1 cup

Frozen Drinks

Frozen Margarita

Makes 4 servings

4 oz. gold tequila	1/4 cup sugar
2 oz. orange and cognac liqueur	3 cups ice
2 Tbs. fresh lime juice	Garnish: Extra lime juice and salt for coating glass rims

1. In jar, place ingredients in order given above.
2. Cover the jar with the lid. Press the **POWER** button. From the **MAIN MENU**, select **Drinks**, then **Frozen Drinks**, and then press the **START/STOP** button.
3. Dip rim of stemmed glasses in lime juice then in salt; pour drink into glasses

Creative Cook's Note: If desired, granulated sugar can be used in place of salt.

Strawberry Daiquiri

Makes 4 servings

1 can (6 oz.) frozen limeade concentrate	1 Tbs. sugar
5 oz. rum	3 1/2 cups ice
1 cup whole strawberries with stems removed	Garnish: Small whole strawberries and lime slices

1. In jar, place ingredients in order given above.
2. Cover the jar with the lid. Press the **POWER** button. From the **MAIN MENU**, select **Drinks**, then **Frozen Drinks**, and then press the **START/STOP** button.
3. Pour into stemmed glasses.
4. Garnish with strawberry and lime slice.

Creative Cook's Note: For variety, substitute fresh raspberries, blackberries or cubed mango, in equal amounts for the strawberries.

Mudslinger

Makes 4 servings

2 oz. coffee-flavored liqueur	2 oz. vodka
2 oz. dark crème de cacao	1/4 cup half-and-half
	3 1/2 cups ice

1. In jar, place ingredients in order given above.
2. Cover the jar with the lid. Press the **POWER** button. From the **MAIN MENU**, select **Drinks**, then **Frozen Drinks**, and then press the **START/STOP** button.
3. Pour into martini glasses.

Piña Colada

Makes 4 servings

1 cup pineapple juice

6 oz. golden rum

2/3 cup cream of coconut

1 tsp. lemon juice

4 cups ice

Garnish: Pineapple slices, maraschino cherries

1. In jar, place ingredients in order given above.
2. Cover the jar with the lid. Press the **POWER** button. From the **MAIN MENU**, select **Drinks**, then **Frozen Drinks**, and then press the **START/STOP** button.
3. Pour into tall glasses.
4. Garnish, if desired, with pineapple slice and cherry

Beach Ball

Makes 5 servings

6 oz. citrus-flavored vodka

2 cups cubed seedless watermelon

1/2 medium banana

3 cups ice

2 tsp. sugar

Garnish: Watermelon triangles

1. In jar, place ingredients in order given above.
2. Cover the jar with the lid. Press the **POWER** button. From the **MAIN MENU**, select **Drinks**, then **Frozen Drinks**, and then press the **START/STOP** button.
3. Pour into tall glasses.
4. Garnish, if desired, with watermelon triangle.

Creative Cook's Note: For variety, substitute cantaloupe or honeydew melon for the watermelon and use the same type of melon for the garnish.

Frozen Sunshine

Makes 4 servings

4 oz. vodka

2 oz. clear orange-flavor liqueur

1/4 cup half-and-half

1/4 cup frozen orange juice concentrate

4 cups ice

Garnish: Orange slices and paper umbrellas

1. In jar, place ingredients in order given.
2. Cover the jar with the lid. Press the **POWER** button. From the **MAIN MENU**, select **Drinks**, then **Frozen Drinks**, and then press the **START/STOP** button.
3. Pour into stemmed glasses.
4. Garnish, if desired, with orange slice and paper umbrella.

Milk Shakes

Strawberry Shake

Makes 2 servings

1 cup milk

2 cups strawberry ice cream

1 cup fresh, ripe strawberries with stems removed

1. In jar, place ingredients in order given above.
2. Cover the jar with the lid. Press the **POWER** button. From the **MAIN MENU**, select **Drinks**, then **Milk Shakes**, and then press the **START/STOP** button.
3. Pour into tall glasses.

Choco-Peanut Butter Shake

Makes 2 servings

1 cup milk

2 cups chocolate ice cream

1/4 cup peanut butter

1/4 tsp. vanilla

1. In jar, place ingredients in order given above.
2. Cover the jar with the lid. Press the **POWER** button. From the **MAIN MENU**, select **Drinks**, then **Milk Shakes**, and then press the **START/STOP** button.
3. Pour into tall glasses.

Brandy Alexander

Makes 4 servings

3 Tbs. milk

4 oz. crème de cacao

2 oz. brandy

2 cups vanilla ice cream

1. In jar, place ingredients in order given.
2. Cover the jar with the lid. Press the **POWER** button. From the **MAIN MENU**, select **Drinks**, then **Milk Shakes**, and then press the **START/STOP** button.
3. Pour into stemmed glasses.

Banana Malted

Makes 2 servings

1/2 cup milk

2 cups vanilla ice cream

2 quartered ripe bananas

1/3 cup malted milk powder

1. In jar, place ingredients in order given above.
2. Cover the jar with the lid. Press the **POWER** button. From the **MAIN MENU**, select **Drinks**, then **Milk Shakes**, and then press the **START/STOP** button.
3. Pour into tall glasses.

Powder Drinks

Coffee Breakfast Cooler

Makes 1 serving

1 cup fat free milk

1 envelope chocolate breakfast drink mix

3 Tbs. malted milk powder

1 Tbs. freeze-dried coffee granules

1 Tbs. protein powder

6 ice cubes

1. In jar, place ingredients in order given above.
2. Cover the jar with the lid. Press the **POWER** button. From the **MAIN MENU**, select **Drinks**, then **Powdered Drinks**, and then press the **START/STOP** button.
3. Pour into tall glass to serve.

Honey-Vanilla Blast

Makes 1 serving

1 cup fat free milk

1 cup (8 oz.) fat free vanilla yogurt

3 chunks frozen banana, about 1 medium

1/4 cup protein powder

2 Tbs. honey

1. In jar, place ingredients in order given above.
2. Cover the jar with the lid. Press the **POWER** button. From the **MAIN MENU**, select **Drinks**, then **Powdered Drinks**, and then press the **START/STOP** button.
3. Pour into tall glass to serve.

Smoothies

Cranberry-Orange Smoothie

Makes 1 serving	1 small ripe banana
3/4 cup orange juice	1 Tbs. honey
1/2 cup raspberry sorbet	3 ice cubes
1/2 cup frozen cranberries	

1. In jar, place ingredients in order given above.
2. Cover the jar with the lid. Press the **POWER** button. From the **MAIN MENU**, select **Drinks**, then **Smoothies**, and then press the **START/STOP** button.
3. Pour into tall glass to serve.

Morning Mocha Smoothie

Makes 1 serving	2 Tbs. chocolate syrup
1/2 cup fat free milk	6 ice cubes
1 cup (8 oz.) low fat coffee yogurt	

1. In jar, place ingredients in order given above.
2. Cover the jar with the lid. Press the **POWER** button. From the **MAIN MENU**, select **Drinks**, then **Smoothies**, and then press the **START/STOP** button.
3. Pour into tall glass to serve.

Very Berry Smoothie

Makes 1 serving	1 cup frozen mixed berries
1 cup orange juice	2 frozen banana chunks, about 1 small
1/2 cup vanilla low fat yogurt	2 Tbs. honey

1. In jar, place ingredients in order given above.
2. Cover the jar with the lid. Press the **POWER** button. From the **MAIN MENU**, select **Drinks**, then **Smoothies**, and then press the **START/STOP** button.
3. Pour into tall glass to serve.

Tropical Power Punch Smoothie

Makes 2 servings

- | | |
|---------------------------------|--------------------------|
| 1 can (6 oz.) pineapple juice | 1 cup mango sorbet |
| 1 can (8 oz.) crushed pineapple | 1/2 tsp. coconut extract |
| | 1 cup ice |

1. In jar, place ingredients in order given above.
2. Cover the jar with the lid. Press the **POWER** button. From the **MAIN MENU**, select **Drinks**, then **Smoothies**, and then press the **START/STOP** button.
3. Pour into tall glasses to serve.

Iced Spiced Chai

Makes 1 serving

- | | |
|---------------------------------|--------------------------|
| 3/4 cup milk | 1/4 tsp. ground cinnamon |
| 3/4 cup orange sherbet | 1/4 tsp. ground nutmeg |
| 2 Tbs. unsweetened iced tea mix | 1/2 cup ice |

1. In jar, place ingredients in order given above.
2. Cover the jar with the lid. Press the **POWER** button. From the **MAIN MENU**, select **Drinks**, then **Smoothies**, and then press the **START/STOP** button.
3. Pour into tall glass to serve.

Sweet Cherry Smoothie

Makes 1 serving

- | | |
|----------------------------------|-------------------------|
| 3/4 cup white grape juice | 1/4 cup milk |
| 1 cup frozen dark sweet cherries | 1/8 tsp. almond extract |
| | 6 ice cubes |

1. In jar, place ingredients in order given above.
2. Cover the jar with the lid. Press the **POWER** button. From the **MAIN MENU**, select **Drinks**, then **Smoothies**, and then press the **START/STOP** button.
3. Pour into tall glass to serve.

Frozen Apple Pie Smoothie

Makes 1 serving

1/2 cup milk

1 cup unsweetened applesauce

1 cup low fat vanilla frozen yogurt

1/4 tsp. ground cinnamon

1/8 tsp. ground nutmeg

4 ice cubes

1. In jar, place ingredients in order given above.
2. Cover the jar with the lid. Press the **POWER** button. From the **MAIN MENU**, select **Drinks**, then **Smoothies**, and then press the **START/STOP** button.
3. Pour into tall glass to serve.

Banana-Berry Blitz

Makes 1 serving

1 cup regular or diet ginger ale

1/2 cup low fat vanilla frozen yogurt

1/2 cup frozen blueberries

3 chunks frozen banana, about 1 medium

1/8 tsp. ground nutmeg

1. In jar, place ingredients in order given above.
2. Cover the jar with the lid. Press the **POWER** button. From the **MAIN MENU**, select **Drinks**, then **Smoothies**, and then press the **START/STOP** button.
3. Pour into tall glass to serve.

Creamy Mint Cookie Smoothie

Makes 1 serving

1/2 cup milk

1 cup low fat vanilla frozen yogurt

6 chocolate-covered chocolate-mint cookies

6 ice cubes

1. In jar, place ingredients in order given above.
2. Cover the jar with the lid. Press the **POWER** button. From the **MAIN MENU**, select **Drinks**, then **Smoothies**, and then press the **START/STOP** button.
3. Pour into tall glass to serve.

Beta Blaster

Makes 2 servings

1 can (12 oz.) carrot juice

1 medium apple, cored and cut into 4 pieces

6 frozen strawberry halves

2 frozen banana chunks, about 1 small

1. In jar, place ingredients in order given above.
2. Cover the jar with the lid. Press the **POWER** button. From the **MAIN MENU**, select **Drinks**, then **Smoothies**, and then press the **START/STOP** button.
3. Pour into tall glasses to serve.

Salsa

Garden Fresh Salsa

Makes 2 cups

1 medium cucumber, pared, cut into 8 pieces
and seeded

1 small onion, cut into 4 pieces

1/2 small green pepper, cut into 4 pieces

1 large garlic clove

12 oz. plum tomatoes, each cut into 4 pieces
and seeded

3 Tbs. red wine vinegar

1 tsp. Worcestershire

1/8 tsp. hot pepper sauce

Salt & pepper to taste

Tortilla chips for serving

1. In jar, place ingredients, except tortilla chips, in order given above.
2. Cover the jar with the lid. Press the **POWER** button. From the **MAIN MENU**, select **Food**, then **Salsas**, and then press the **START/STOP** button.
3. Pour into bowl; serve with tortilla chips.

Pineapple-Mango Salsa

Makes 3 cups

1/2 medium red pepper, cut into 4 pieces

1/2 medium red onion, cut into 4 pieces

1-inch piece gingerroot, peeled, cut into 4 pieces

1 cup pineapple chunks

1 cup fresh mango chunks

1 Tbs. lime juice

1 cup rinsed, drained black beans

Tortilla chips for serving

1. In jar, add ingredients, except beans and tortilla chips, in order given above.
2. Cover the jar with the lid. Press the **POWER** button. From the **MAIN MENU**, select **Food**, then **Salsas**, and then press the **START/STOP** button.
3. Pour into bowl; stir in beans.
4. Serve with tortilla chips.

Fiery Red Salsa

Makes 3 cups

2 large garlic cloves

1 medium onion, cut into 8 pieces

2 - 4 jalapeño peppers, quartered

1/2 cup cilantro leaves

1/2-1 tsp. sugar

2 cans (15 oz. each) whole tomatoes,
drained

1 Tbs. lime juice

Salt to taste

Tortilla chips for serving

1. In jar, add ingredients, except tortilla chips, in order given above.
2. Cover the jar with the lid. Press the **POWER** button. From the **MAIN MENU**, select **Food**, then **Salsas**, and then press the **START/STOP** button.
3. Pour into bowl; serve with tortilla chips.

Creative Cook's Note: When handling hot peppers, such as jalapeños, use rubber gloves, and keep hands away from your eyes.

Salsa Verde

Makes 1 1/2 cups

1/2 small onion, cut into 4 pieces

1/2 small green pepper, cut into 4 pieces

2 garlic cloves

1/4 cup cilantro leaves

1/2 tsp. ground cumin

1/4 tsp. green hot pepper sauce

1/8 tsp. salt

12 oz. tomatillos, roasted, husks removed

Tortilla chips for serving

1. In jar, place ingredients, except tortilla chips, in order given above.
2. Cover the jar with the lid. Press the **POWER** button. From the **MAIN MENU**, select **Food**, then **Salsas**, and then press the **START/STOP** button.
3. Pour into bowl; serve with tortilla chips.

Soups

Creamy Carrot-Dill Soup

Makes 4 servings

1 small onion, chopped

1 Tbs. butter or margarine

1 lb. baby carrots

2 cups chicken broth

1 Tbs. chopped fresh dill

Salt to taste

1 cup half-and-half or milk

1. In 3-qt. saucepan, cook onion in butter 5 minutes or until onion is tender.
2. Add carrots, broth and dill; cook over medium heat 15-18 minutes or until carrots are very tender.
3. In jar, place carrots, broth, dill and salt.
4. Cover the jar with the lid. Press the **POWER** button. From the **MAIN MENU**, select **Food**, then **Soups**, and then press the **START/STOP** button.
5. Return mixture to saucepan; stir in half-and-half.
6. Gently heat to 145° F; do not let soup boil.

Creative Cook's Note: Soup can be served chilled or hot.

Cuban Black Bean Soup

Makes 4 servings

2 cans (15-19 oz. each) black beans
1 small onion, chopped
2 garlic cloves, crushed
2 Tbs. olive oil

1 cup water
1/2 cup sofrito*
1 Tbs. chopped cilantro
Sour cream, chopped red onion, cilantro for serving, optional

1. Rinse and drain beans; set aside.
2. In 4-qt. saucepan, cook onion and garlic in oil 5 minutes or until tender.
3. Add beans, water, sofrito and cilantro.
4. Cook over medium heat 12-15 minutes or until hot.
5. In jar, place 3 cups beans and liquid.
6. Cover the jar with the lid. Press the **POWER** button. From the **MAIN MENU**, select **Food**, then **Soups**, and then press the **START/STOP** button.
7. Stir bean mixture into soup remaining in saucepan; re-heat as desired.
8. Serve, if desired, with sour cream, red onion, and cilantro.

*sofrito is a popular condiment in Latin American cooking. It can be found in the Latin American or International foods section of most supermarkets.

Creative Cook's Note: If a totally blended soup is preferred, repeat step # 3 with remaining beans and liquid.

Cream of Tomato Soup

Makes 4 servings

4 cups chopped fresh tomatoes
1 small onion, chopped
1 Tbs. chopped fresh basil

2 Tbs. butter
1/2 tsp. salt
1 cup half-and-half or milk

1. In 3-qt. saucepan, cook tomato, onion and basil in butter 5 minutes or until onion is tender.
2. Pour mixture into jar; add salt.
3. Cover the jar with the lid. Press the **POWER** button. From the **MAIN MENU**, select **Food**, then **Soups**, and then press the **START/STOP** button.
4. Return soup to saucepan; stir in half-and-half.
5. Gently heat to 145° F; do not let soup boil.

Tuscan Bean Soup

Makes 8 servings

- | | |
|--|---|
| 1 can (15-19 oz.) cannellini beans
(white kidney) | 1 cup chopped red onion |
| 1 can (15-19 oz.) chickpeas (garbanzos) | 1 tsp. dried sage |
| 1 can (15-19 oz.) red kidney beans | 2 Tbs. olive oil |
| 1 can (15-19 oz.) pinto beans | 2 cups water |
| 1 cup chopped celery | 2 cups cooked small pasta, such as ditalini |
| | Grated Parmesan cheese and chopped parsley
for serving, optional |

1. Rinse and drain beans; set aside.
2. In 4-qt. saucepan, cook, celery, onion, garlic and sage in oil 5 minutes or until tender.
3. Add beans and water; cook over medium heat 15-18 minutes or until hot.
4. In jar, place 3 cups of beans and liquid.
5. Cover the jar with the lid. Press the **POWER** button. From the **MAIN MENU**, select **Food**, then **Soups**, and then press the **START/STOP** button.
6. Stir bean mixture and pasta into soup remaining in saucepan; re-heat.
7. Serve, if desired, with grated cheese and parsley.

Baby Food

Peachy Applesauce

Makes 1 1/4 cups

- | | |
|---|---|
| 1 large apple, pared, cored and quartered | 1 large peach, pitted, peeled and quartered |
| | 2 Tbs. water |

1. In small saucepan, cook fruits in water 5-8 minutes or until very tender.
2. In jar, place fruits and liquid.
3. Cover the jar with the lid. Press the **POWER** button. From the **MAIN MENU**, select **Food**, then **Baby Food**, and then press the **START/STOP** button.
4. Remove from jar; place in covered containers.
5. Chill or freeze at once.

Green Peas

Makes 1 1/2 cups

3/4 cup water

1 pkg. (10 oz.) frozen baby green peas

1. In small saucepan, cook peas in water 10-15 minutes or until very tender.
2. In jar, place peas and liquid.
3. Cover the jar with the lid. Press the **POWER** button. From the **MAIN MENU**, select **Food**, then **Baby Food**, and then press the **START/STOP** button.
4. Remove from jar. Place in covered containers.
5. Chill or freeze at once.

Chicken-Rice Dinner

Makes 1 cup

1 cup cubed or shredded cooked chicken

2/3 cup water

1/4 cup cooked white rice

1. In jar, place ingredients in order given above.
2. Cover the jar with the lid. Press the **POWER** button. From the **MAIN MENU**, select **Food**, then **Baby Food**, and then press the **START/STOP** button.
3. Remove from jar; place in covered containers.
4. Chill or freeze at once.

Sweet Potatoes

Makes 2 cups

1 cup water

2 cups pared sweet potato chunks

1. In small saucepan, cook potatoes in water, 15-20 minutes until very soft.
2. Drain potatoes; set aside liquid.
3. In jar, place liquid then potatoes.
4. Cover the jar with the lid. Press the **POWER** button. From the **MAIN MENU**, select **Food**, then **Baby Food**, and then press the **START/STOP** button.
4. Remove from jar; place in covered containers.
5. Chill or freeze at once.

Batter

Lemon Crepes

Makes 14-18

1 1/2 cups milk

3 eggs

2/3 cup flour

2 Tbs. melted butter or margarine

2 Tbs. granulated sugar

1 tsp. grated lemon zest

Confectioners' sugar for serving, optional

1. In jar, place ingredients, except confectioners' sugar, in order given above.
2. Cover the jar with the lid. Press the **POWER** button. From the **MAIN MENU**, select **Food**, then **Batter**, and then press the **START/STOP** button.
3. For each crepe, pour 2 to 3 Tbs. batter onto a preheated, lightly buttered 6 or 7-inch crepe pan or skillet. Cook about 1 minute or until top is set. Loosen edge with heatproof spatula, and then gently turn crepe over. Cook until lightly golden.
4. If desired, fold each crepe into quarters and sprinkle with confectioners' sugar.

Honey-Wheat Pancakes

Makes 12 pancakes

1 1/3 cups low fat buttermilk

2 eggs

2 Tbs. honey

1 1/2 cups reduced-fat buttermilk baking mix

1/2 cup whole-wheat flour

1/4 cup honey-crunch wheat germ

1 tsp. baking powder

Butter and syrup for serving

1. In jar, add ingredients in order given above.
2. Cover the jar with the lid. Press the **POWER** button. From the **MAIN MENU**, select **Food**, then **Batter**, and then press the **START/STOP** button.
3. For each pancake, pour about 1/4 cup batter onto preheated griddle; cook until tops begin to bubble; turn over and continue to cook until golden.
4. Serve hot with butter and syrup.

Fruit-Filled Popover

Makes 2-4 servings

3 Tbs. butter

3/4 cup milk

3 eggs

2 Tbs. granulated sugar

1/2 tsp. ground cinnamon

1/2 cup flour

2 cups sliced fresh fruit

(berries, peaches, etc.)

Confectioners' sugar for serving

1. Preheat oven to 425° F.
2. In 10" skillet with oven-safe handle, place butter. Place skillet in oven to melt butter. Meanwhile, in jar, place remaining ingredients, except fruit and confectioners' sugar, in order given.
3. Cover the jar with the lid. Press the **POWER** button. From the **MAIN MENU**, select **Food**, then **Batter**, and then press the **START/STOP** button.
4. Remove skillet from oven and carefully pour in batter.
5. Bake 20-25 minutes until edges are golden brown and center is puffed; center will fall slightly when removed from oven.
6. To serve, fill with fruit and sprinkle with confectioners' sugar.

Nuts/Crumbs

Walnut-Cheddar Ball

Makes 12 servings

1 cup walnut halves

1 pkg. (8 oz.) cream cheese, softened

2 cup (8 oz.) shredded mild cheddar cheese

1/4 cup peach-apricot sweet-and-sour sauce

1 tsp. curry powder

1/8 tsp. ground red pepper

Assorted crackers for serving

1. In jar, place walnuts.
2. Cover the jar with the lid. Press the **POWER** button. From the **MAIN MENU**, select **Food**, then **Nuts/Crumbs**, and then press the **START/STOP** button.
3. Remove nuts and set aside.
4. In medium bowl, combine remaining ingredients, except crackers.
5. Shape mixture into a ball, cover and chill.
6. Just before serving, roll ball in nuts.
7. Arrange ball on serving platter and surround with assorted crackers.

Chocolate Cream Pie

Makes 8 servings

1/3 cup slivered almonds
 20 chocolate wafer cookies
 1/4 cup melted butter
 2 pkg. (3.4 oz. each) chocolate pudding and pie filling

3 1/2 cup milk
 1/2 tsp. almond extract
 1 1/2 cups heavy cream
 1/3 cup chocolate syrup
 Garnish: White chocolate curls

1. In jar, place almonds. Then break cookies into jar.
2. Cover the jar with the lid. Press the **POWER** button. From the **MAIN MENU**, select **Food**, then **Nuts/Crumbs**, and then press the **START/STOP** button.
3. Spray a 9" pie plate with nonstick cooking spray; add crumbs and butter; mix well then press into bottom and up side; chill.
4. Prepare pie filling with milk as package directs; stir in extract; chill.
5. In medium bowl, place cream and chocolate syrup; whip until soft peaks form.
6. Pour chilled pie filling into crust; spread chocolate whipped cream over filling.
7. Garnish with chocolate curls.
8. Chill several hours.

Pecan-Crusted Chicken

Makes 4 servings

1 cup pecan halves
 2 eggs

3 Tbs. Dijon mustard
 1 lb. boneless, skinless chicken breast
 1/4 cup butter

1. In jar, place pecans.
2. Cover the jar with the lid. Press the **POWER** button. From the **MAIN MENU**, select **Food**, then **Nuts/Crumbs**, and then press the **START/STOP** button.
3. Remove nuts and set aside.
4. In small bowl, beat eggs with mustard.
5. Dip chicken into egg mixture then coat with nuts.
6. In a medium skillet, over medium-high heat, cook chicken in butter until golden brown on both sides and juices run clear.

Creative Cook's Note: For a quick party hors d'oeuvres, cut chicken into strips, then dip in egg mixture, coat in nuts and cook as directed. Place cooked chicken strips on a platter and serve with bottled honey mustard or sweet and sour sauce.

This accessory can be purchased at retail outlets or at Authorized Oster® Appliance Service Centers. Only use the accessory model number listed below with this unit.

Blend-N-Go™ Cup

This single serve blending cup has 24 oz. (750ml) of usable capacity. The lid features a slider pad to prevent spills. The Blend-N-Go™ Cup attaches to 6700 or 6710 bases by means of an Oster® Collar with triple blades.

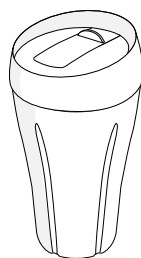

Sunbeam® Products, Inc. (“Sunbeam®”) warrants that for a period of two years from the date of purchase, this product will be free from defects in material and workmanship. Sunbeam®, at its option, will repair or replace this product or any component of the product found to be defective during the warranty period. Replacement will be made with a new or remanufactured product or component. If the product is no longer available, replacement may be made with a similar product of equal or greater value. This is your exclusive warranty.

This warranty is valid for the original retail purchaser from the date of initial retail purchase and is not transferable. Keep the original sales receipt. Proof of purchase is required to obtain warranty performance. Sunbeam® dealers, service centers, or retail stores selling Sunbeam® products do not have the right to alter, modify or in any way change the terms and conditions of this warranty.

This warranty does not cover normal wear of parts or damage resulting from any of the following: negligent use or misuse of the product, use on improper voltage or current, use contrary to the operating instructions, disassembly, repair or alteration by anyone other than Sunbeam® or an authorized service center. Further, the warranty does not cover Acts of Nature, such as fire, flood, hurricanes and tornadoes.

Sunbeam® shall not be liable for any incidental or consequential damages caused by the breach of any express or implied warranty. Except to the extent prohibited by applicable law, any implied warranty of merchantability or fitness for a particular purpose is limited in duration to the duration of the above warranty. Some states, provinces or jurisdictions do not allow the exclusion or limitation of incidental or consequential damages or limitations on how long an implied warranty lasts, so the above limitations or exclusion may not apply to you. This warranty gives you specific legal rights, and you may also have rights that vary from state to state or province to province.

How to Obtain Warranty Service

Take the product to an Authorized Oster® Appliance Service Center. You may obtain a list of service centers and other repair/replacement instructions by calling:

(800) 334-0759

Or send e-mail to:

Consumeraffairs@consumer.Sunbeam.com

Please include name, address, telephone number, product model number, and description of the problem and date of purchase.

If you purchased this product outside the U.S. or Canada, please see country specific insert or contact your local authorized distributor.

DO NOT RETURN THIS PRODUCT TO THE PLACE OF PURCHASE.

NOTES



NOTES



NOTES



For product questions:

Sunbeam Consumer Service

PO BOX 948389

Maitland, FL 32794-8389

Do not send product to the above address.

©2001 Sunbeam Corporation. All rights reserved.

Sunbeam® and Oster® are registered trademarks of Sunbeam Products, Inc. Blend-N-Go™ Cup, and In2itive™ are trademarks of Sunbeam Corporation or its affiliated companies. Distributed by Sunbeam Products, Inc., Boca Raton, FL 33431, or an affiliated company.

Rev. 8/8/01 01.

The Oster logo is rendered in a blue, stylized script font. The letter 'O' is significantly larger and more ornate than the other letters, featuring a small star-like shape inside its upper curve. The word 'Oster' follows in a similar script, with a registered trademark symbol (®) at the end.