

FLYCAM

HD Video Stabilizer

INSTRUCTION MANUAL



All rights reserved

No part of this document may be reproduced, stored in a retrieval system, or transmitted by any form or by any means, electronic, mechanical, photocopying, recording, or otherwise, except as may be expressly permitted by the applicable copyright statutes or in writing by the publisher.

INTRODUCTION

Smaller, lighter, faster is the latest industry trend in DSLR cameras and video camcorders. Many have features that rival those of their big brothers with amazing results. Recognizing the need to match newer technology in image capture with the camera platforms that support them, Flycam has developed an all new FLYCAM HD Hand Held Camera Stabilizer.

IN THE BOX

lease inspect the contents of your shipped package to ensure you have received all that is pictured and listed below.

Note: 1. If you have purchased FLYCAM HD-5000(FLCM-HD5-QT) or FLYCAM HD-3000 (FLCM-HD-3-QT), you will receive all the items mentioned below:



HEAD ASSEMBLY

- Head Plate
- Mid Plate
- Bottom Plate

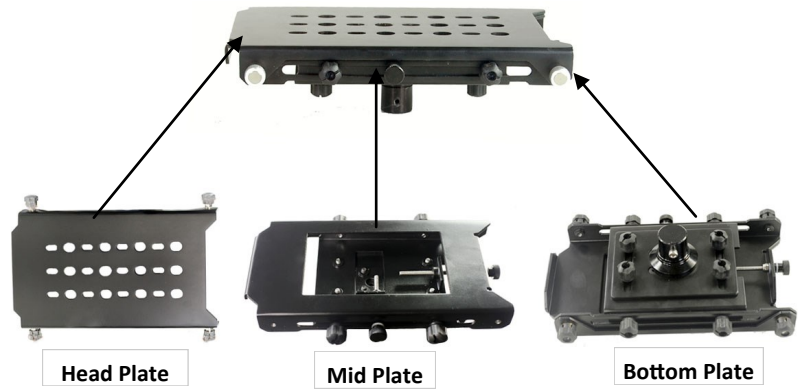

These three individual pieces are shipped as one assembled unit.

Note: The threaded stud is located in the center of the base plate for attach it with central post.



BASE PLATFORM

Provided with 16 weights to balance the camera on stabilizer.



ASSEMBLING YOUR HD VIDEO STABILIZER

Note: Assembling steps are same for both Stabilizers.

- Attach central post on base plate and tighten it with the help of a thread to ensure a slip free connection.
- Alignment should end up with central post being perpendicular to base platform as pictured. This will make camera balancing and operation much easier.



ATTACHING HEAD PLATE ASSEMBLY TO CENTRAL POST

- Loosen head plate with help of allen key and then place it on central post. Then tighten the screws with help of allen key.



DETERMINING YOUR CAMERA'S CENTER OF BALANCE AND MOUNTING PROCEDURE

- Remove Head Plate from 2-piece head assembly in preparation to attach it to quick release plate. Loosen plate and place it on head plate and then tighten with help of screw driver. Attach head plate and tighten screws as shown below.



- Remove quick release top plate from the set up and attach your camera to it then tighten it with help of screw driver.



THE CAMERA'S CENTER OF BALANCE

Hold your camcorder using two fingers of one hand as shown in the picture. Slowly and with care, move your fingers back and forth until the camera appears balanced. With your other hand, slide the Head Plate to center under your fingers. Using a grease pencil or marker, mark the location on the base plate underneath the 2 finger balance point. This should be the center of balance.



- Align camera center of balance to bottom plate and securely attach Head Plate with camera set up to bottom plate.
- There are 2x Knobs (Knob-1, Knob-2) located on bottom Plate, allow you to easily adjust horizontally and vertically for perfect camera balance. Once achieved, tighten side screws to secure.



ADDING WEIGHTS AND POSITIONING FOR PROPER BALANCE

- Continuing the assembly and balance requirements to make your Flycam HD fully functional you will note that the base platform has a provision to mount the balance weights via 2x BH bolts secured with knobs on both sides of the post.



- The purpose of the counter weight system is to match the low end of the stabilizer to the weight of the camera and accessories at the high/top end with the gimbaled handle as the pivot point in between.
- The heavier the camera and accessories, the more weights are required to achieve proper balance. Generally as you add weight to one side of the central post, an equal amount has

- to be added to the other side to maintain horizontal balance.
- However if you are using an offset configuration such as a flip out viewfinder or off center accessories, extra weights might be needed on the opposite side of the post to counter act and maintain proper balance.

VERTICAL STALK ADJUSTMENT

The up and down (vertical) position of the telescopic central post is adjusted by loosening the control located at the base, raising or lowering the stalk to achieve desired location and then retightening the vertical control.

Do not over-tighten this control.



BALANCING YOUR FLYCAM HD HANDHELD STABILIZER

Before beginning the balancing process check the following:

- Camera is securely attached to head plate.
- Lens cap has been removed and secured.
- Telescoping clamp has been tightened.
- Weight discs are added successfully.
- All the screws are tightened securely.
- Battery & all cables should be secured.

BALANCING THE HORIZONTAL AXIS

When your Flycam HD Hand held stabilizer is properly assembled, you can start the test and setup of the horizontal balance. Horizontal balance allows the camera to remain level during operation with the Central Post in a vertical position unless off axis framing is desired.

When testing for horizontal balance start from a flat and level surface like a table. This will allow Flycam Hand held stabilizer to hang freely as you hold it. If your Flycam HD Handheld Stabilizer is correctly balanced on its horizontal axis, then it will be both level & upright, with the Central Post in a perfect vertical position.

Warning: If you do not have enough weight on the Base Platform the entire FLYCAM could flip upside down. Should this movement start to happen be ready to catch the stalk before a complete 180 degree occurs. This type of unwanted movement requires more weight to be added to the base with additional weight discs.

Another way to accomplish horizontal balance is to move the center of gravity of the camera by re-bolting the camera to a different area of the Head and Bottom Plate, either front to back or side to side.

Should Flycam HD Handheld stabilizer be front heavy, loosen the screws on the sides of the Head Plate and gently slide Head Plate back until optimum balance is achieved.

Tilting to the back means the load is tail heavy requiring the plate to be adjusted forward on the head.

Always secure the screws after any adjustments.

If you cannot achieve front to back axis balance with this method, then try remounting your camera to a different hole on Head Plate. Having achieved horizontal balance for the front to back axis, tighten the screws on the Head Plate.

If the Flycam HD Hand held stabilizer leans to the right, then loosen screws on the bottom of Bottom Plate and then gently slide the bottom Plate to left. If it leans to the left from the operator's point of view, then adjust the bottom Plate to the right. A bit at a time until balance is achieved.

Secure all screws after adjustments are made.

It may be necessary to reconfigure front to back adjustments once correct side-to-side fine-tuning has been accomplished.

Another option to consider is moving the Counter Weight discs back & forth on the Base Platform by sliding them either closer to or further away from the Center Post via the built in base slots. Make sure to tighten the discs down should you move them.

BALANCING THE VERTICAL AXIS

The sled should be tied up to the docking adapter of your stand or similar so that you can start the fore & after balancing adjustments by centering the camcorder over the central post. To do this:

- Loose side screws of head plate and bottom screws of the bottom plate.
- Look at Flycam HD Handheld stabilizer from the side. If the camcorder lens is tipped up or down, move the camcorder forward or backwards until the center of balance is situated over the central post.
- Then, look at the Flycam HD Handheld stabilizer from the front. If the post is not vertical, adjust bottom plate until the center post is vertical.
- You can also adjust weight discs closer to & further away from the sled as per requirement till the post is not vertical.

The stability of the Flycam HD depends on it being slightly bottom heavy. If it is top heavy, it will tilt more. If it is too bottom heavy, it will be sluggish and hard to aim.

**Slightly bottom heavy, it will be both stable and easier to control.
Check the vertical balance by using this drop time test.**

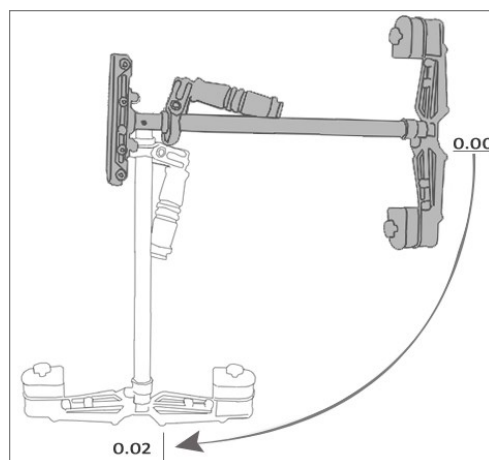

- Make sure that everything is tight and position yourself behind the stand.
- Grasp the center post near the base and move the center post from vertical to horizontal.
- Hold it there. Be sure that it will not hit the stand when you drop the center post and put your free hand to catch the center post when it drops.
- Count how many seconds it will take to fall to vertical. Try using a stopwatch.
- If the drop time is less than 2 seconds, it is too bottom heavy. You need to move the bottom mass closer to the post.
- If the drop time is more than two seconds, it is top heavy.

A DROP TIME OF 2 - 2.5 SECONDS IS PREFERRED.

***Note:** Recheck the balance by looking at the sled. If necessary, use side screws and bottom plate screws to make required adjustments.*

BALANCING REVIEW

Proper system balance can only be achieved once your camera is set up with appropriate accessories ready for shooting. This means batteries, lenses, media cards, LCD viewfinder/monitor, quick release plate, on-cam lights, and all the gear you will use for your recording session.

- Remove top plate of FLYCAM and line up your camera so that its center of gravity is as close to the center of the plate as possible (basically hold the camera in your hand until it feels balanced both left and right as well as forward and back).
- Find hole in the plate that is as close to threaded tripod mount on your camera as possible (while you are still holding your camera's center of gravity to the center of the plate). Attach your camera (or quick release mount if you have one). Tighten it down so it won't accidentally rotate.
- Re-attach top plate to the FLYCAM . Center it, but don't worry about getting it absolutely perfect yet.
- Remove most of the weights from Base Platform, but leave one on each side.
- Insert the center post as far as it will go and tighten so it won't slide out.
- Hold the handle normally and turn the FLYCAM so that it is horizontal to the ground. Let go of the stalk while keeping a firm grip on the handle and count how long it takes to return to vertical again. You should be able to count a good, "One-one thousand, two-one thousand", before it rights itself. With only two little weights it might take considerably longer.
- Add one pair of weights at a time and repeat the "horizontal to vertical" test until it falls at the correct rate. It will probably not be perfect.
- You'll get one that's too slow and then you'll add a pair and it will fall too fast. When that happens, take off the last pair of weights that you added.
- Tighten down the weights so they don't slide around.

- To get count perfect, slightly lower the center post that attaches the Base Platform with the weights until you get the "one-one thousand, two one thousand" count to the vertical position.
- Fine-tune the left-right, forward-backward balance. You will have to go back and forth between the two directions to get the balance just right. Loosen the screw sets that allow the sled to move left and right. Adjust the top plate so that it is centered and tighten down the screws like you would a tire slowly and alternating side to side.
- Repeat for "forward-backward" balancing.
- Check to see if your camera is sitting level. If not, repeat the necessary steps until it does.
- Practice walking/movements ensuring your body motion is not transmitted to your hands and then the FLYCAM and camera.

HOLDING YOUR FLYCAM HD STABILIZER

When handling your Flycam HD Handheld Stabilizer one hand holds onto the handle while the other is used to gently guide the camera in the direction you wish to shoot and frame the shot. For normal shooting, hold the handle in the middle.

For shots that require framing the camera up, down or sideways, hold the handle firmly at the bottom.

This will allow the “yoke” part of the gimbal to rotate without hitting your hand or knuckles.



MAINTENANCE

Bearing Maintenance

The main Bearing on your Flycam HD Handheld Stabilizer is attached to the Central Post about two inches from the top. It is of metal construction and partially enclosed by the Bearing assembly.

If after a period of time your bearings don't turn smoothly, lubricate with a minimum of light machine oil. Light lubricating oil can also be used on the Yoke and Handle Bearings.

Be sure to keep oil away from your camera, & clean up any over spill.

Cleaning

Do not use solvents or harsh cleaners of any kind on your Flycam HD Hand held stabilizer. If the unit becomes dirty, use a damp soft cloth or sponge and a mild detergent to gently clean external parts.

Storage

Should you need to store your Flycam HD Hand held stabilizer for a long period of time then place the unit upright in a dry or low to normal humidity area whenever possible. If you are unable to find this kind of environment then we suggest you store the unit in an airtight plastic container or bag. Standing the unit upright is preferred as it alleviates stress on the system.

NOTE: Flycam HD Handheld Stabilizer doesn't work under water, nor is it waterproof. Avoid direct exposure to rain, water spray or any harsh environment. The bearings are not sand proof. Avoid getting dirt or sand in them.

PRACTICE MAKES PERFECT - WALKING THE LINE

Practice this simple exercise to master your Flycam HD Hand held stabilizer with professional results.

Using masking or gaffers tape, create a cross mark on a flat and even wall. The mark becomes your framing center. On the floor leading up to the cross mark, lay a straight tape line of about 20 feet. Practice walking the line, while keeping the cross mark center framed and in focus. With a bit of effort, dramatic fluid like movements will become second nature and provide production value to all your set ups.

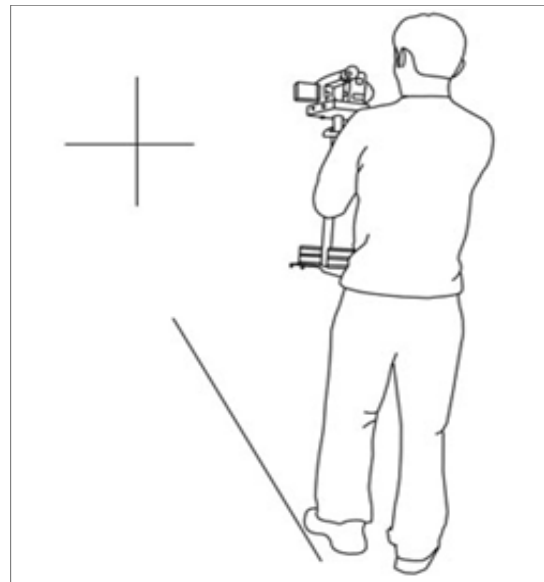

If you wish to use Table clamp then please follow the below steps.

- Attach clamp onto the table, tighten the provided knob to secure. Then attach handle onto the clamp, it helps achieving balance in just seconds and saves your professional time.



YOUR CAMTREE HUNT FLYCAM HD HAND HELD STABILIZER
ALL DRESSED UP AND GOOD TO GO



WARRANTY

We offer a limited time warranty for our products. For Mechanical products we provide a 6 month warranty & for electronic products we provide a 3 month warranty from the date of purchase.

We will repair or replace your product, free of charge, in the event of a defect in materials or craftsmanship obtained during normal use or handling based on the user manual. Please note that we will not cover any shipping costs for returning the product to us. If any VAT or import duties are applied to the return, we will also charge these costs to the customer.

The warranty does not include, by the way of example, damage caused by products that we do not supply or from mishandling in transit, accident, misuse, neglect, lack of care of the product , or service by anyone other than our company.

We are not liable for incidental or consequential damages resulting from the use of the unit or occurring due to any breach of this warranty.

Replacement parts of the product will be provided at nominal cost (covering the cost price of the replacement parts only) to the customers after the Warranty Period has expired. We will cover the complete cost of sending replacement parts within the warranty period. After that, Nominal cost of the product & Actual shipping cost will be charged.

Do not send the unit to us without first getting a response and getting the approval to send back the item.

In case of any kind of dissatisfaction, we urge you to **Contact us** immediately and we shall do our best to help you out.

For any other assistance you can reach us via email.