



TYGER[®]

TYGER ARMOR™

TG-AM2T20148

Parts List

- x1** Driver Side Armor
- x1** Passenger Side Armor
- x12** 8-1.25mm x 30mm Hex Bolts
- x12** 8mm Lock Washers
- x12** 8mm x 24mm OD x 2mm Flat Washers

Before Installation

READ INSTRUCTIONS CAREFULLY BEFORE STARTING INSTALLATION. REMOVE CONTENTS FROM BOX AND VERIFY ALL PARTS ARE PRESENT. ASSISTANCE IS RECOMMENDED.

Torque Value

Fastener Size	Class 8.8 Tightening Torque (ft-lbs)	Class 10.9 Tightening Torque (ft-lbs)
6mm	6-7	6-7
8mm	15-16	22-23
10mm	31-32	44-45
12mm	54-55	78-79
14mm	87-88	125-126

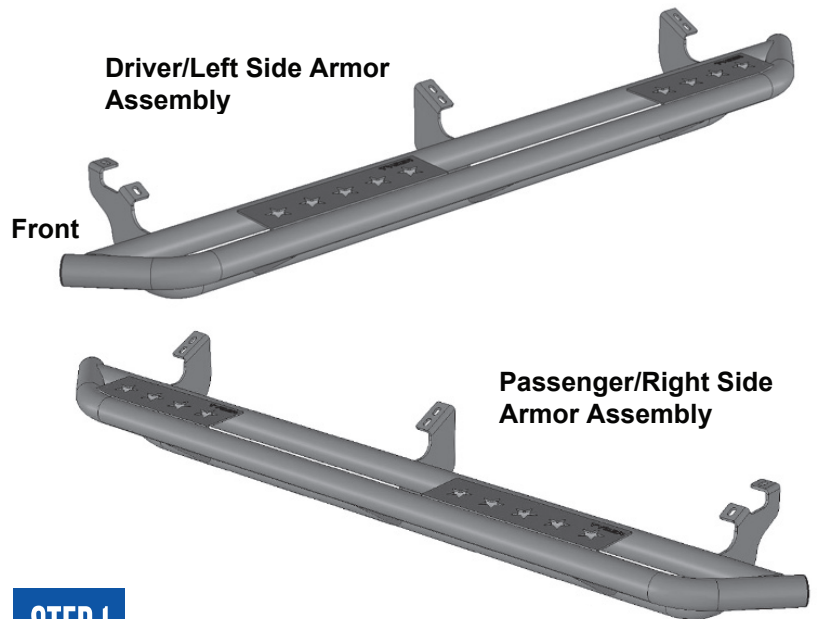

STEP 1

Starting on the driver/left side of the vehicle, remove the existing (2) factory bolts, (or plugs), located by the front tire opening, (Figure 1). Move to the center and rear mounting locations and remove the hex bolts or plugs as necessary, (Figures 2 & 3).

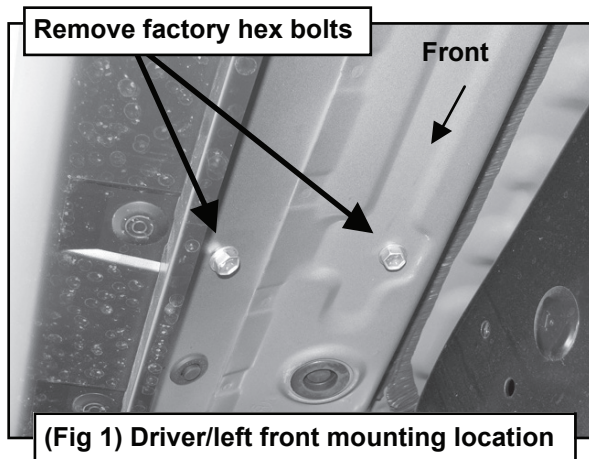



TYGER[®]

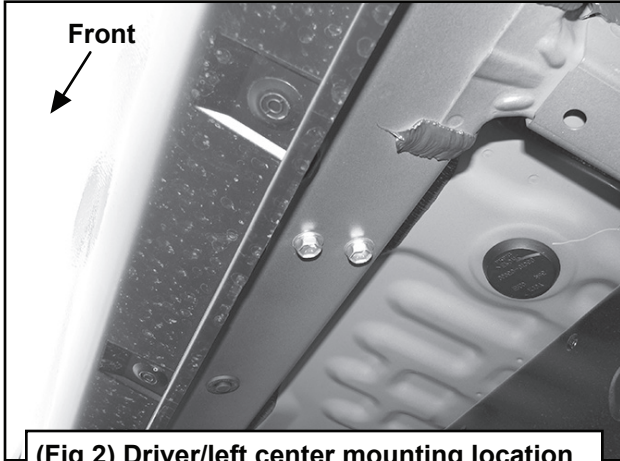

(Fig 2) Driver/left center mounting location

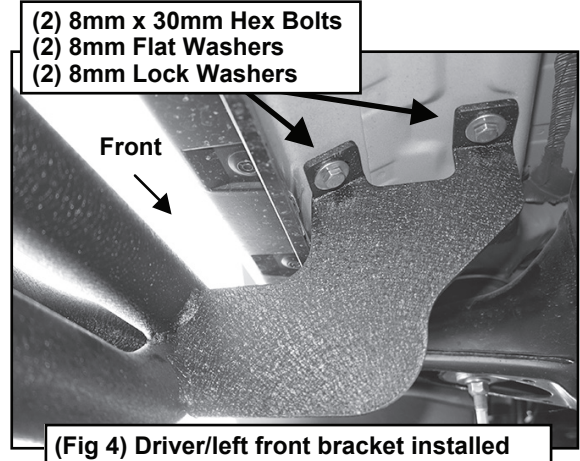

(Fig 4) Driver/left front bracket installed

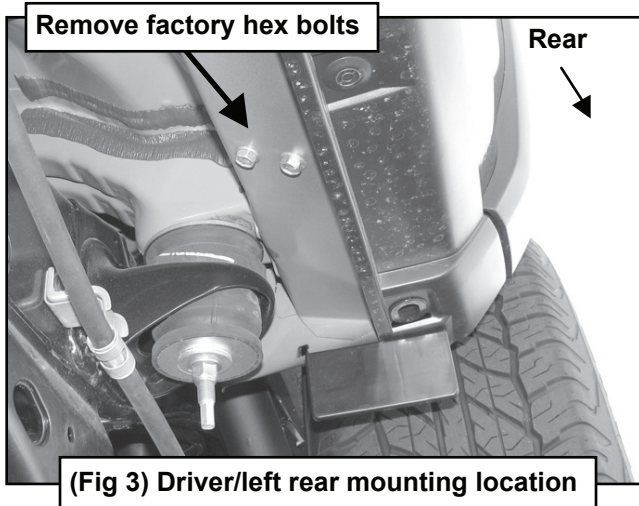

(Fig 3) Driver/left rear mounting location

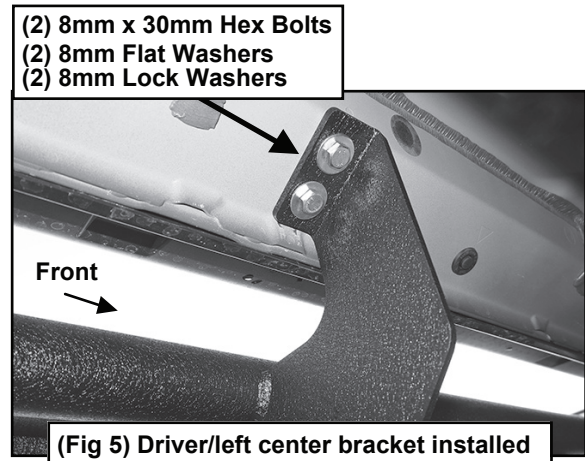

(Fig 5) Driver/left center bracket installed

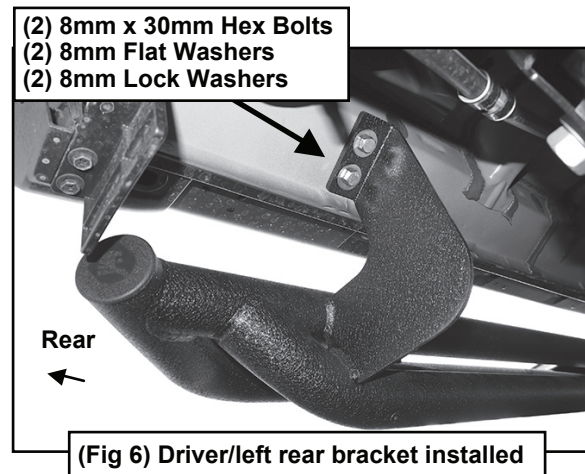

(Fig 6) Driver/left rear bracket installed

STEP 2

Select the driver/left Side Armor assembly. With assistance, hold the assembly up in position against the bottom of the body panel. Attach the assembly to the mounting locations with the included (6) 8mm x 30mm Hex Bolts, (6) 8mm Lock Washers and (6) 8mm Flat Washers, (Figures 4-6). Do not fully tighten hardware at this time.



TYGER[®]

STEP 3

Align and adjust the assembly as necessary and fully tighten all hardware.

STEP 4

Repeat Steps 1-3 for driver/left Side Armor installation.

STEP 5

Do periodic inspections to the installation to make sure that all hardware is secure and tight.

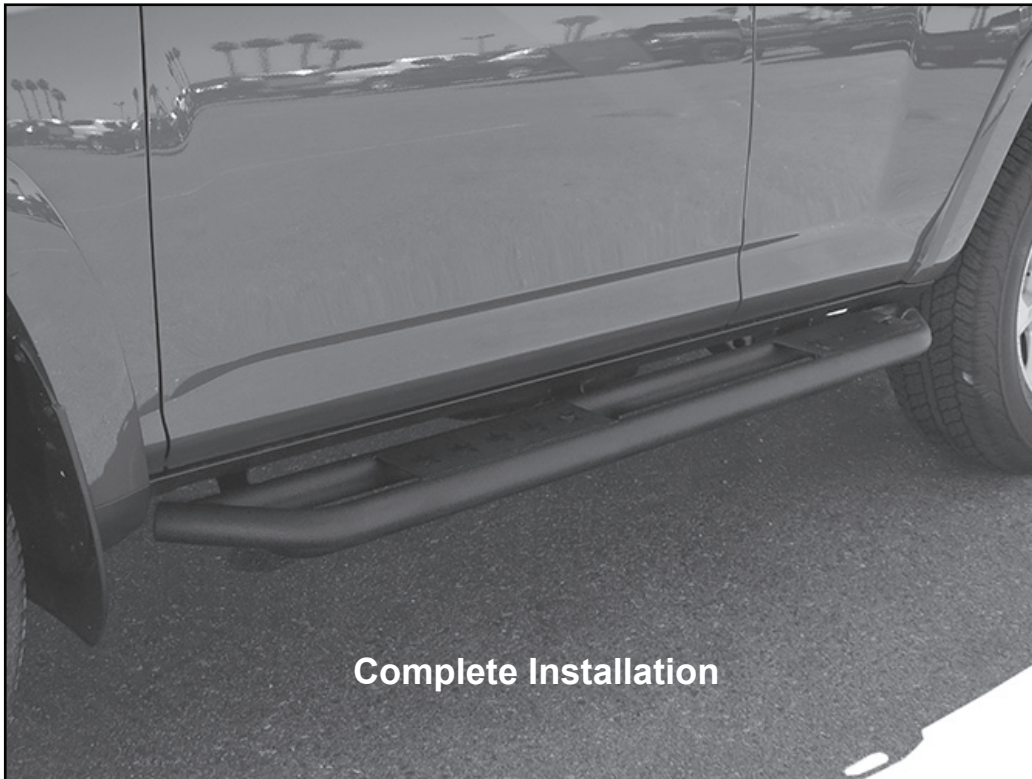

Complete Installation