

CORALIFE®

LED BioCube®

Size 32 Instructions

Please read these instructions in their entirety before attempting to use this product.



A product of Central Aquatics
(Division of Central Garden & Pet Company)
Franklin, WI 53132
888.255.4527 corallifeproducts.com
Coralife is a registered trademark
of Central Garden & Pet Company
©2016 Central Garden & Pet Company

Watch the product video at:
corallifeproducts.com



IMPORTANT SAFETY INSTRUCTIONS

1. WARNING – To guard against injury, basic safety precautions should be observed, including the following:

READ AND FOLLOW ALL SAFETY INSTRUCTIONS.

2. DANGER – To avoid possible electric shock, special care should be taken since water is employed in the use of aquarium equipment. For each of the following situations, do not attempt repairs by yourself; return the appliance to an authorized service facility for service or discard the appliance:
 - A. If the appliance falls into the water, DON'T reach for it! First unplug it and then retrieve it. If electrical components of the appliance get wet, unplug the appliance immediately.
 - B. If the appliance shows any sign of abnormal water leakage, immediately unplug it from the power source.
 - C. Carefully examine the appliance after installation. It should not be plugged in if there is water on parts not intended to be wet.
 - D. Do not operate any appliance if it has a damaged cord or plug, or if it is malfunctioning or has been dropped or damaged in any manner.
 - E. To avoid the possibility of the appliance plug or receptacle getting wet, position aquarium stand and tank to one side of a wall-mounted receptacle to prevent water from dripping onto the receptacle or plug. A "drip loop," shown in figure below, should be arranged by the user for each cord connecting an aquarium appliance to a receptacle. The "drip loop" is that part of the cord below the level of the receptacle, or the connector if an extension cord is used, to prevent water traveling along the cord and coming in contact with the receptacle. If the plug or receptacle does get wet, DON'T unplug the cord. Disconnect the fuse or circuit breaker that supplies power to the appliance. Then, unplug and examine for presence of water in the receptacle.
3. Close supervision is necessary when any appliance is used by or near children.
4. To avoid injury, do not contact moving parts or hot parts such as heaters, reflectors, lamp bulbs, and the like.
5. Always unplug an appliance from an outlet when not in use, before putting on or taking off parts, and before cleaning. Never yank cord to pull plug from outlet. Grasp the plug and pull to disconnect.
6. Do not use an appliance for other than intended use. The use of attachments not recommended or sold by the appliance manufacturer may cause an unsafe condition.

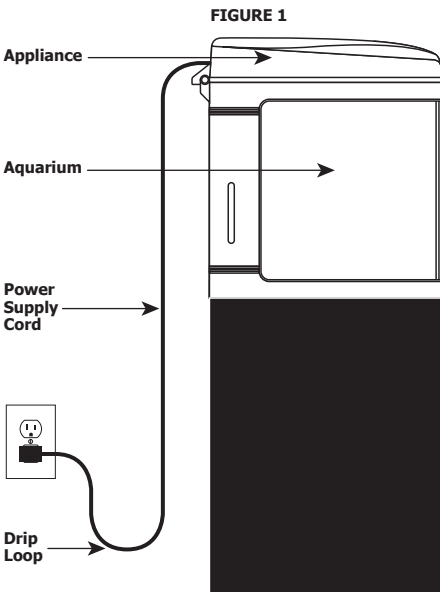

7. Do not install or store the appliance where it will be exposed to the weather or to temperatures below freezing.
8. Make sure an appliance mounted on a tank is securely installed before operating it.
9. Read and observe all the important notices on the appliance.
10. If an extension cord is necessary, a cord with a proper rating should be used. A cord rated for less amperes or watts than the appliance rating may overheat. Care should be taken to arrange the cord so that it will not be tripped over or pulled.
11. For added safety, the fixture must be plugged into a receptacle controlled by a GFI (ground fault interrupter) circuit breaker. Device must be properly connected to a grounded three-prong receptacle.
12. Do not use this appliance in such a way that the vents are restricted or blocked. These vents are necessary to avoid over-heating and insure safe operating temperature.
13. This appliance is intended FOR HOUSEHOLD USE ONLY.

SAVE THESE INSTRUCTIONS!

IMPORTANT SAFETY INFORMATION: Please read the following precautions before use!

1. To reduce the risk of electric shock, always unplug the pump and power cords before performing any maintenance. Do not submerge canopy.
2. Never allow small children to touch, climb-on, or play with the aquarium or its stand. Adult supervision is required.
3. Never place an aquarium on the floor, it can cause injury or become damaged.
4. Never set an aquarium on an unsteady or unsupported structure, such as those which are unable to support the weight of a filled aquarium, are suspended, can rock or sway, can sag, or on wheels or allows the aquarium to over-hang. These could cause the aquarium to leak, crack, or even fall over if a top heavy situation is created.
5. Aquarium supports that are less than 12" wide (front and back) should be fastened or tethered to a wall to prevent a top heavy or unstable condition.
6. Do not allow water pump to operate dry at any time.
7. Always observe proper maintenance to ensure optimal operation.

HANDLE WITH CARE! Always handle aquarium with care to avoid personal injury.

1. Never lift or attempt to move an aquarium that is not completely empty, partially full or filled.
2. Never lift an aquarium with wet hands.
3. Never attempt to lift an aquarium by grasping the upper edges of the frame or from the canopy.
4. Always lift or carry an empty aquarium by supporting it from the bottom of the tank.

AQUARIUM LOCATION

1. For best results, place an aquarium in a location best suited to support the total weight of the aquarium. The filled weight of an aquarium is approximately 10-12 lbs. per gallon of water and add the weight of sand, gravel, rocks or decorations.
2. Always place an aquarium in a flat and level area.
3. Avoid placing an aquarium where it will receive direct sunlight. Full or even partial sunlight can cause algae growth.
4. Keep aquarium in a well ventilated area away from a heating or cooling vent.
5. Do not place near electronic components and systems (i.e. TV, stereo systems, etc.).

PARTS DIAGRAM

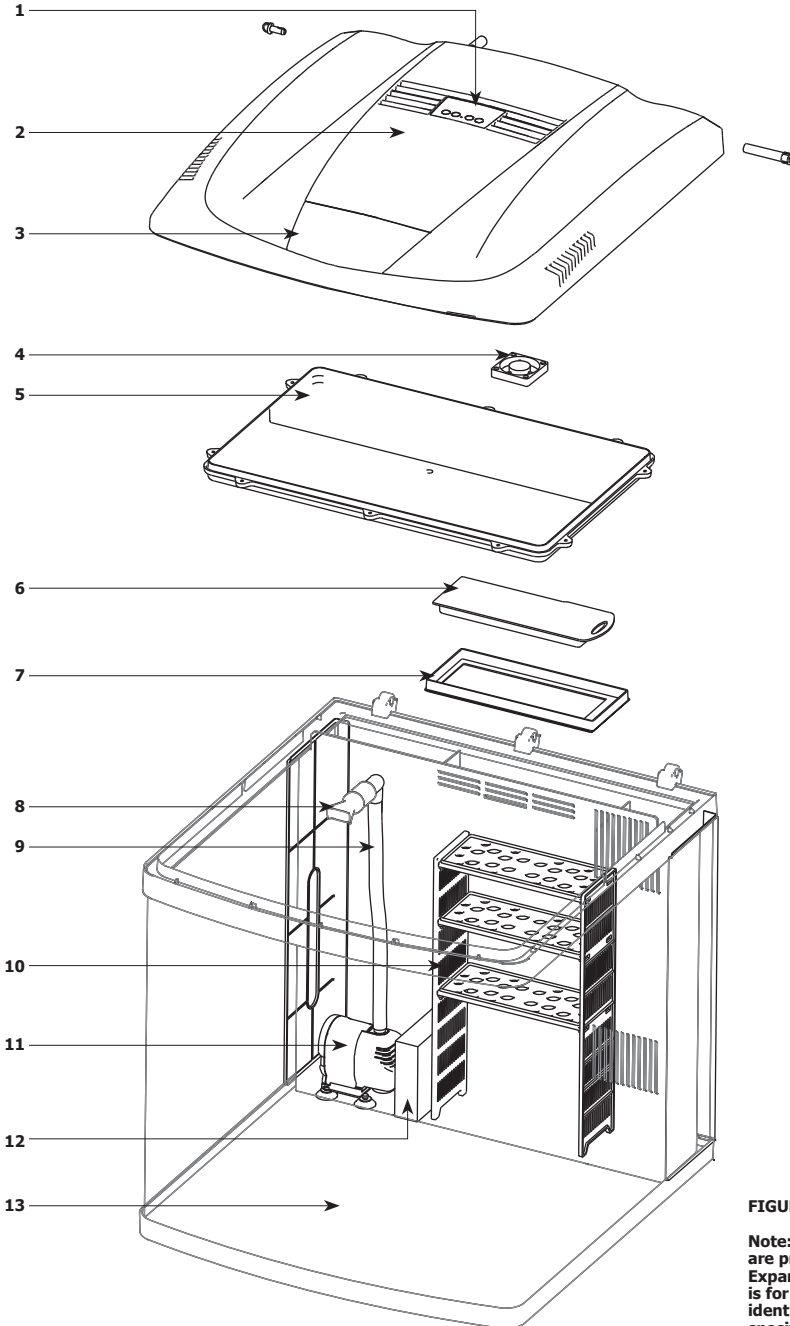

FIGURE 2

Note: Parts 1-13 are pre-assembled. Expanded view is for parts identification, specification and replacement.

PARTS IDENTIFICATION

Part #	Item Description
1	24 Hour Timer
2	Canopy
3	Feeding Door
4	Cooling Fan
5	Light Lens Cover
6	Filter Cartridge (Fits BioCube® sizes 14, 16, 29 and 32)
7	Overflow Tray
8	Output Discharge Nozzle
9	Flexible 0.5" I.D. Tubing
10	Media Tray
11	Water Pump
12	Sponge Filter
13	Glass Aquarium

PRODUCT SPECIFICATION

LED BioCube®	Size 32
Item No.	100115662
UPC No.	096316156623
Dimension	20.25" L x 21.875" W x 19.125" H
Cooling Fan	50 mm, 15.83 CFM, 25.5 Db
Pump Flow Rate	264 gph (1000 l/h)
PAR*	53
Peak PAR @ 12"	81
Lux*	2200
Peak Lux @ 12"	3430

*Average output of a 20" x 16" area @ 12" from the light

ASSEMBLY

Safety Precautions:

1. Do not plug BioCube® into an outlet or power source until setup and installation is completed.
2. Visually inspect the aquarium and canopy prior to installation to make sure it has not been damaged.

Wet/Dry Filter Assembly (Figure 3)

1. Add desired media (biological or chemical) on top of the trays in the second chamber and drop the media tray into place.
2. Place the BioCube® filter cartridge into the slot provided on the cartridge holder above the media tray.
3. Make sure that the sponge filter is correctly placed in the third chamber of the wet/dry section with the water pump properly assembled and connected to the wet/dry return output.

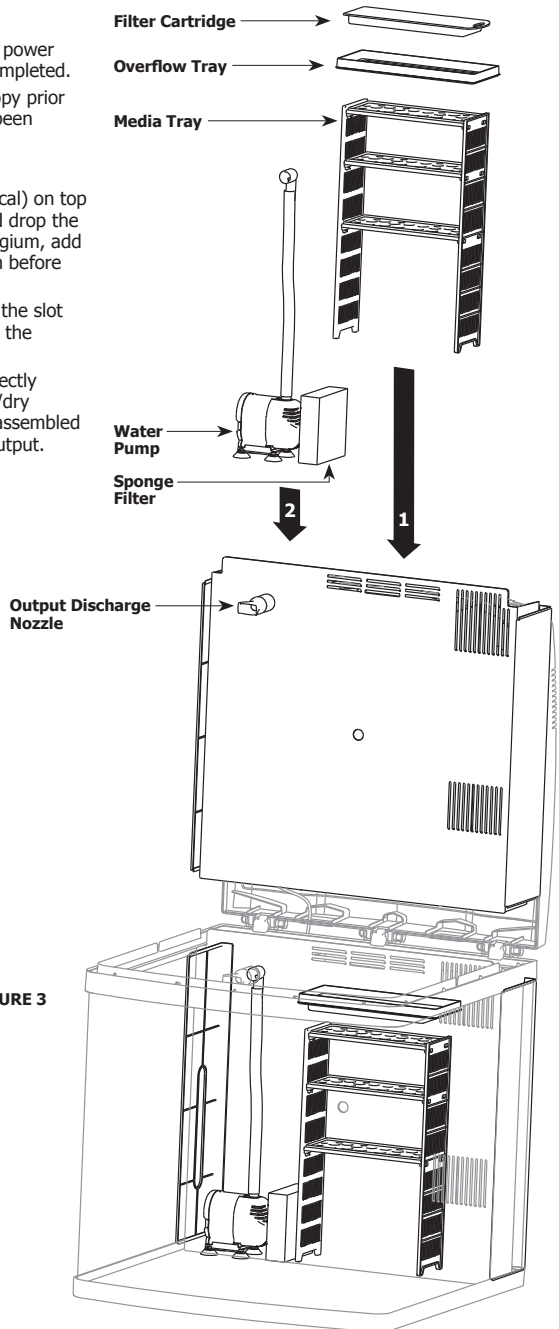

FIGURE 3

TIMER INSTRUCTIONS

Lighting Startup Operation

1. Plug the power supply into an acceptable outlet or power source. Be sure to incorporate a "drip loop" to prevent water droplets from running down the cord and into the outlet should any water get onto the cord.
2. Turn the hood on and follow instructions below to program the timer.

Timer Programming Instructions

Selecting a Program:

1. Press MENU and then use the UP or DOWN arrows to search for your desired program.
 - ALL = All LEDs will turn on (at full power)
 - LC1 = Only Daytime LEDs will turn on
 - LC2 = Only Sunrise/Sunset LEDs will turn on (They will start at low power and increase incrementally over 30 minutes)
 - LC3 = Only Moon Glow LEDs will turn on (They will start at low power and increase incrementally over 60 minutes)
 - CLO = Set the timer for all LEDs (You must press MENU again to set the clock and program the timer)
 - SHO = Demo mode will turn on

Demo (SHO) Mode:

Perfect for showcasing your new LED Lighting, this mode cycles through a 24-hour lighting sequence in just 3 minutes.

- Sunrise: 30 sec
- Moonrise: 30 sec
- Day Time: 60 sec
- Moonset: 30 sec
- Sunset: 30 sec
- Night Time: 60 sec

Please Note: Except under CLO mode, pressing MENU again or waiting 30 seconds without pressing anything will exit back to clock display. Pressing MENU in CLO mode will enter clock and timer program mode.

To Set Time of Day (CLO Mode):

1. Choose 12 or 24 Hour Mode:
 - a. '12H' will appear on the display. Press the UP arrow key to change to '24H' clock mode. Pressing the DOWN arrow key will change the mode back to '12H'.
2. Press MENU to move to the next step.
3. ⌚ will appear on the screen to indicate clock setting function. If 12H mode was selected, clock will display '12:00am' with the '12' blinking. If 24H mode was selected, will display '0:00am' with the '0' blinking.
4. Press arrow keys UP or DOWN to set the hour.
5. Press MENU to move to minutes. Use the arrow keys UP or DOWN to set the minutes.
6. When time setting is complete, press MENU to move to the next step – Programming Channel 1.

Programming Channel 1 - Daylight LEDs

'1' and 'On' will appear on the screen to indicate timer setting for channel 1.

7. Press arrow keys UP or DOWN to set the hour.

8. Press MENU to move to minutes. Use the arrow keys UP or DOWN to set the minutes.
9. Press MENU to move to 'off' time for channel 1. Repeat steps 7 and 8.
10. When Channel 1 programming is complete press MENU to move to the next step – Programming Channel 2.

Programming Channel 2 - Color Enhancing LEDs (Automatic Sunrise/Sunset Function)

'2' and 'On' will appear on the screen to indicate timer setting for channel 2.

11. Press arrow keys UP or DOWN to set the hour.
12. Press MENU to move to minutes. Press arrow keys UP or DOWN to set the minutes.
13. Press MENU to move to 'off' time for channel 2. Repeat steps 11 and 12.
14. When Channel 2 programming is complete press MENU to move to the next step – Programming Channel 3.

When setting Channel 2 the start time and stop time will indicate when Sunrise mode will initially light up and when Sunset mode will initially dim down. LEDs will gradually ramp up or dim down for 30 minutes from the set time.

Programming Channel 3 - Moon Glow LEDs (Automatic Moonrise/Moonset Function)

'3' and 'On' will appear on the screen to indicate timer setting for channel 3.

15. Press arrow keys UP or DOWN to set the hour.
16. Press MENU to move to minutes. Press arrow keys UP or DOWN to set the minutes.
17. Press MENU to move to 'off' time for channel 3. Repeat steps 15 and 16.
18. When Channel 3 programming is complete press MENU to Exit programming mode and return to the clock time display.

When setting Channel 3 the start time and stop time will indicate when Moonrise mode will initially light up and when Moonset mode will initially dim down. LEDs will gradually ramp up or dim down for 60 minutes from the set time.

Timer Function Notes:

- If at any time in programming the timer there is no activity for 30 seconds the timer will immediately return back to clock time display.
- If at any time the power is turned off the following will occur when the hood is reactivated:
 - Setting will default to the programmed settings (CLO Mode)
 - If in daytime – the Sunrise feature will start automatically. Maximum brightness will occur after 30 minutes.
 - If in nighttime – the Moonrise feature will start automatically. Maximum brightness will occur after 60 minutes.

OPERATION

Cooling Fan

1. Make sure that the cooling fan is on and blowing across the unit.

FIGURE 4

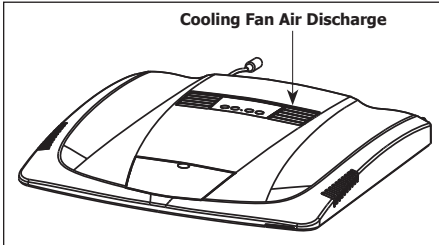

WARNING:

Do not obstruct cooling fan air input and cooling fan air discharge.

Keep canopy vents clean from dust and debris.

Wet/Dry Filter Start-Up Operation

1. Open canopy and remove filter cartridge. Rinse thoroughly with cool freshwater and reinstall in 1st chamber.
2. Rinse substrate, sand, gravel, rocks, driftwood, plants and ornaments and add to aquarium.
3. Prepare aquarium water (saltwater/freshwater). Make sure water is at room temperature to prevent condensation.
4. Slowly add water to the aquarium. Make sure to fill aquarium up to the lower edge of the top moulding (Figure 5).

FIGURE 5

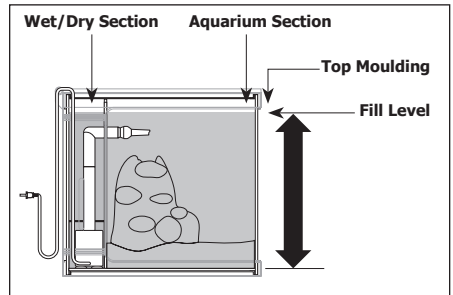

5. Plug water pump power cord into an outlet or power source. Pump will raise water level in aquarium section and drain into wet/dry section (Figure 6).

FIGURE 6

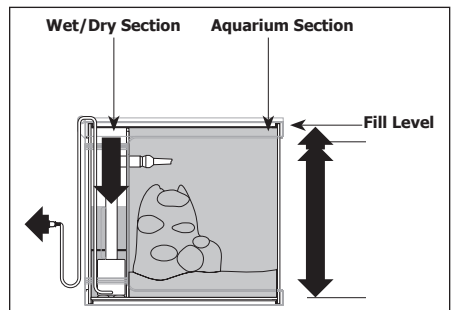

6. Because chamber 1 has a high and stable water level, it is recommended to insert an aquarium heater in this section, as required.

WET/DRY FILTRATION OPERATION

Wet/Dry Filtration

Observe and make sure that the water circulation is flowing properly from the aquarium section through the wet/dry section.

Step 1:

Water proceeds into surface and bottom intake.

FIGURE 7

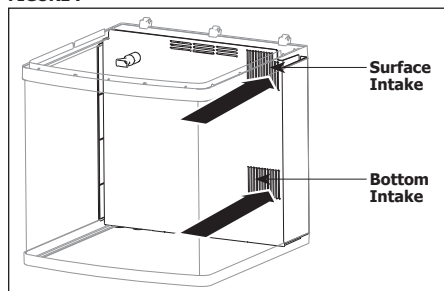

Step 2:

Water passes through filter cartridge.

FIGURE 8

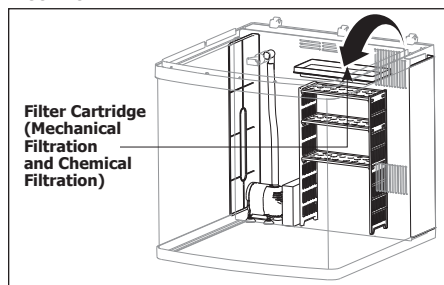

Step 3:

Water flows through the overflow tray, then trickles down through the media tray.

FIGURE 9

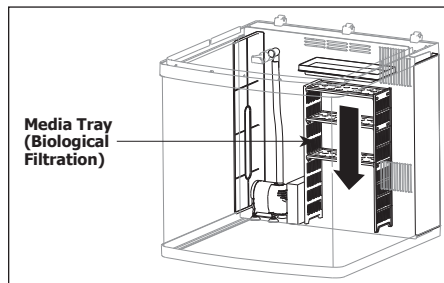

Step 4:

Water goes through the sponge filter into the water pump.

FIGURE 10

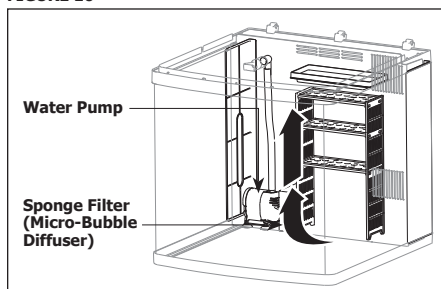

Step 5:

Water is pumped into the aquarium through the output discharge nozzle.

FIGURE 11

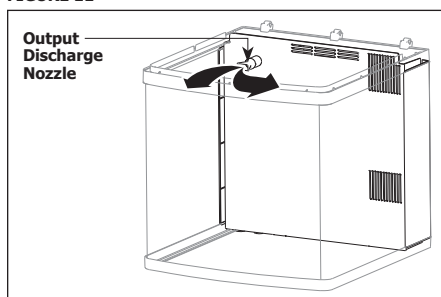

PRECAUTIONS:

For optimal filter performance

1. Do not block or obstruct surface intake and bottom intake.
2. Do not block or obstruct output discharge nozzle.
3. Perform scheduled maintenance on filter cartridge.
4. Observe scheduled maintenance on water pump.
5. Make sure to perform scheduled water changes and BioCube® filtration maintenance.

MAINTENANCE

WARNING!

Make sure LEDs are turned off and unplug power cords from power source or outlet before performing any maintenance.

FIGURE 12

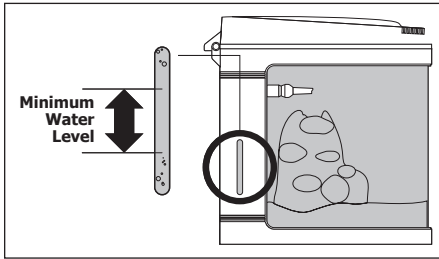

Daily Maintenance

1. Visually observe the BioCube® lighting and filtration to make sure that the system is functioning properly.
2. Check water level. Make sure to replace evaporated water with freshwater to replenish water supply (Figure 12).

Note: Use only freshwater to replace evaporated water for both freshwater and saltwater setup.

Caution: Do not let water get below the minimum water level.

Weekly Maintenance

1. Keep BioCube® surfaces clean from dust and debris. Wipe exposed surfaces with a clean and dampened soft terry cloth.
2. Open canopy and wipe down light lens cover with a clean and dampened soft terry cloth.
3. Inspect filtration system for clogging and excessive accumulation of debris. Clean and remove debris from surface, bottom intake and overflow tray. Rinse parts if needed.

Note: If using Bio-Balls or other biological media in chamber 2, it is important to avoid cleaning the bio-media to avoid removing the beneficial bacteria needed to break down ammonia and nitrites.

Monthly Maintenance

1. Remove used filter cartridge and discard (Figure 13). Replace with new cartridge.
Note: Make sure to rinse new filter cartridge with cool freshwater before installing inside BioCube®.
2. Remove sponge filter from wet/dry section. Rinse and clean sponge with cool freshwater to remove accumulated organic buildup (Figure 13).

FIGURE 13

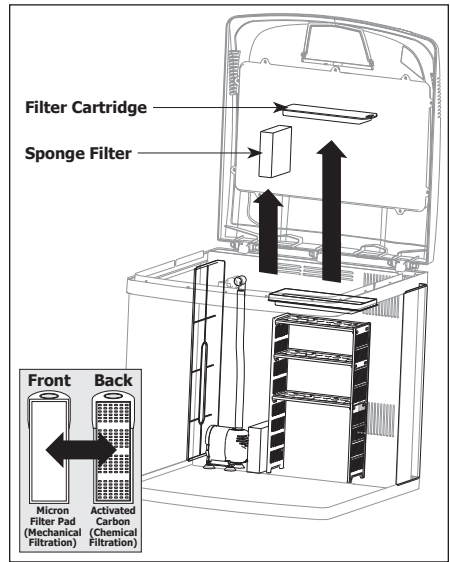

3. Disconnect water pump assembly from output elbow attachment and detach pump from flexible tubing (Figure 14).

FIGURE 14

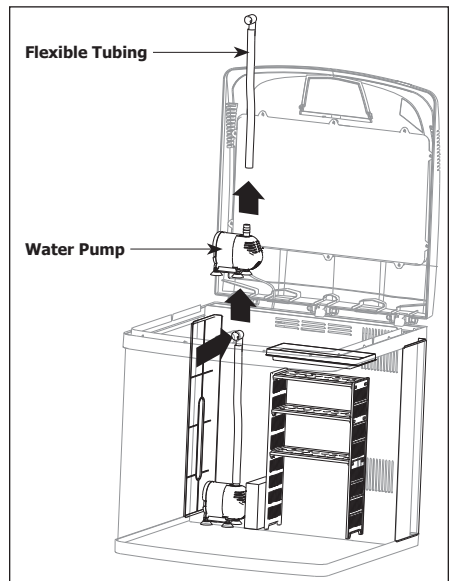

MAINTENANCE

4. Disassemble pump and impeller. Rinse and wipe down all parts to dislodge debris and particulate matter (Figure 15).

Note: If calcium buildup is present, soak in a vinegar solution with 1 part vinegar : 1 part water for 1 hour and rinse thoroughly.

FIGURE 15

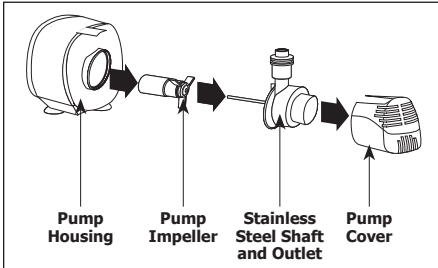

5. Clean the light lens cover with a soft cloth to remove debris.

LIMITED WARRANTY

Central Aquatics warrants that this product shall be free from defective electrical components and leaks or cracks due to defects in materials or workmanship for a period of twelve months from the date of purchase. If a defect is shown, Central Aquatics will, at Central Aquatics's sole discretion, either repair or replace the product without charge. No cash refunds will be made. This warranty is provided solely to the original consumer purchaser of the product and may not be transferred or assigned.

This warranty does not apply to damage resulting from accident, misuse, abuse, lack of reasonable care, failure to follow safety and installation instructions, use of the product with non-standard electrical service, or any other defect not resulting from defects in the electrical components of the product or defects in materials or workmanship. This warranty will not be effective unless and until the Coralife product is shown to have been used in accordance with the safety and installation instructions accompanying the product, including the requirement that the product be placed on a flat, level surface designed to support the product.

THIS CONSTITUTES CENTRAL AQUATICS' ENTIRE WARRANTY AND CENTRAL AQUATICS MAKES NO OTHER WARRANTIES, WHETHER EXPRESS OR IMPLIED, WITH RESPECT TO THE PRODUCT. CENTRAL AQUATICS SPECIFICALLY DISCLAIMS ANY AND ALL IMPLIED WARRANTIES, INCLUDING, WITHOUT LIMITATION, WARRANTIES OF MERCHANTABILITY AND FITNESS FOR A PARTICULAR PURPOSE. IF CENTRAL AQUATICS CANNOT LAWFULLY DISCLAIM IMPLIED WARRANTIES UNDER THIS LIMITED WARRANTY, ALL SUCH WARRANTIES, INCLUDING WARRANTIES OF MERCHANTABILITY AND FITNESS FOR A PARTICULAR PURPOSE ARE LIMITED IN DURATION TO THE DURATION OF THIS WARRANTY.

CENTRAL AQUATICS IS NOT RESPONSIBLE FOR DIRECT, SPECIAL, INCIDENTAL OR CONSEQUENTIAL DAMAGES RESULTING FROM ANY BREACH OF WARRANTY OR CONDITION, OR UNDER ANY OTHER LEGAL THEORY. CENTRAL AQUATICS EXPRESSLY DISCLAIMS ALL ALLEGED DAMAGES FOR LOSS OF AQUATIC LIFE, PERSONAL INJURY, AND/OR PROPERTY DAMAGE. Some states and provinces do not allow the exclusion or limitation of incidental or consequential damages or exclusions or limitations on the duration of implied warranties or conditions, so the above limitations or exclusions may not apply to you. This warranty gives you specific legal rights, and you may also have other rights that vary by state or province.

Central Aquatics shall not have any obligations under this warranty unless the owner notifies Central Aquatics in writing of any alleged defect(s) within 30 days of discovery of the defect(s). Any notice to CENTRAL AQUATICS must be delivered by United States or electronic mail to one of the following addresses:

U.S. Mail

Central Aquatics
5401 W. Oakwood Park Drive
Franklin, Wisconsin 53132

Electronic Mail

customerservice@coralifeproducts.com

Central Aquatics shall be allowed a reasonable period of time to investigate any warranty claim and to perform any testing Central Aquatics deems necessary to determine the cause of the defect. This warranty shall be interpreted under the laws of the state of Wisconsin.

For additional information regarding this limited warranty, please contact us at the addresses above, or call us at 888-255-4527.