



# Owner's Manual

**RBC-5000**

## **HIGH SPEED BILL COUNTER**



With Ultraviolet, Magnetic and Infrared  
Counterfeit Detection

*Please read and retain these instructions.  
To register your product, please go to [www.royalsovereign.com](http://www.royalsovereign.com)  
USA-Customer Support Tab then Registration Tab.*

**[www.royalsovereign.com](http://www.royalsovereign.com)**

**Royal Sovereign International, Inc.**

## SAFETY INSTRUCTIONS

### **Warning**

When using this machine follow these basic safety precautions to reduce risk of fire, electric shock or injury.

1. Do not place the machine in area where it may be exposed to water or other liquids.
2. Before cleaning the machine always unplug the machine from the wall. Do not use liquid or aerosol cleaners on the machine.
3. To reduce the risk of electrical shock, do not take apart the machine. When service or repair work is needed bring it to a qualified service repair technician.
4. Only use the power cord that comes with the machine. Using a different power cord may result in electric shock, fire or cause serious damage to machine.
5. Do not use the machine in areas with high temperature or high humidity. This may result in the machine not working properly.

### **Caution**

1. When unplugging the power plug, grip the plug to pull it out. Pulling the cord may result in electric shock, fire or damage to the machine.
2. Do not use the machine if the power cord is damaged. This may result in electric shock, fire or other hazards.
3. Do not place objects on the power cord and do not bend it excessively. This may result in electric shock, fire or other hazards.
4. When not using the machine for long periods of time, unplug the power cord from the outlet.

# **CONTENTS**

---

<b>Box Contents &amp; Parts</b> .....	<b>4</b>
<b>Display and Function Keys</b> .....	<b>5</b>
<b>Features</b> .....	<b>6-7</b>
<b>Operation</b> .....	<b>7</b>
<b>Error Messages and Solutions</b> .....	<b>8-9</b>
<b>Specifications</b> .....	<b>9</b>
<b>Warranty</b> .....	<b>10</b>

## BOX CONTENTS

Bill Counter, Power Cord

## PARTS

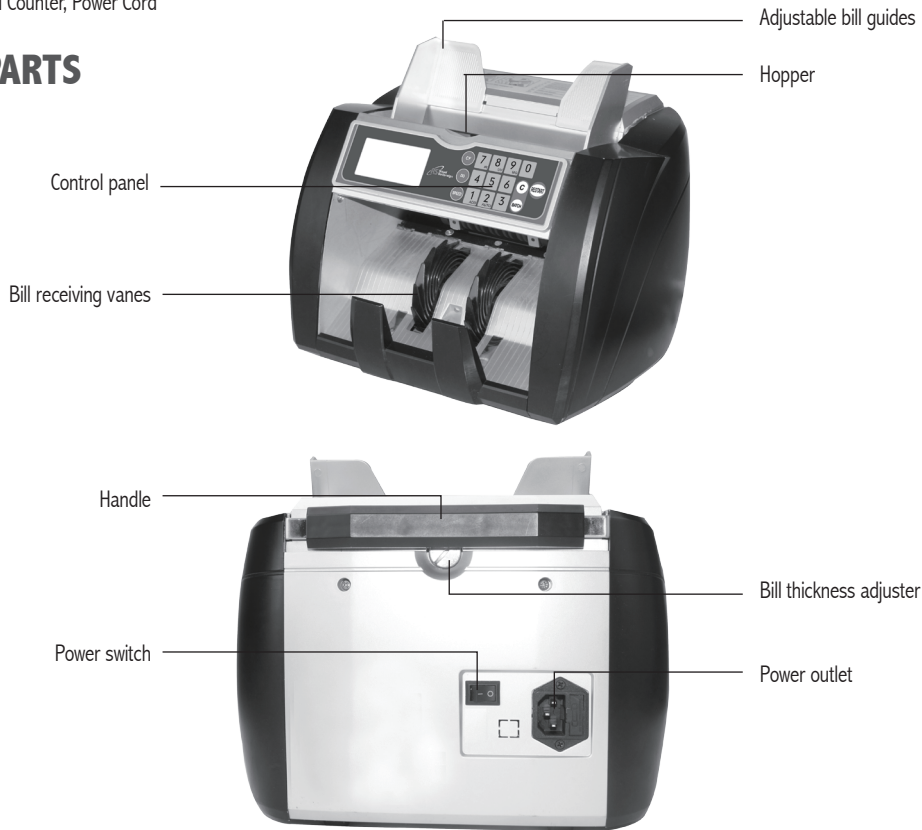

## Display and function keys

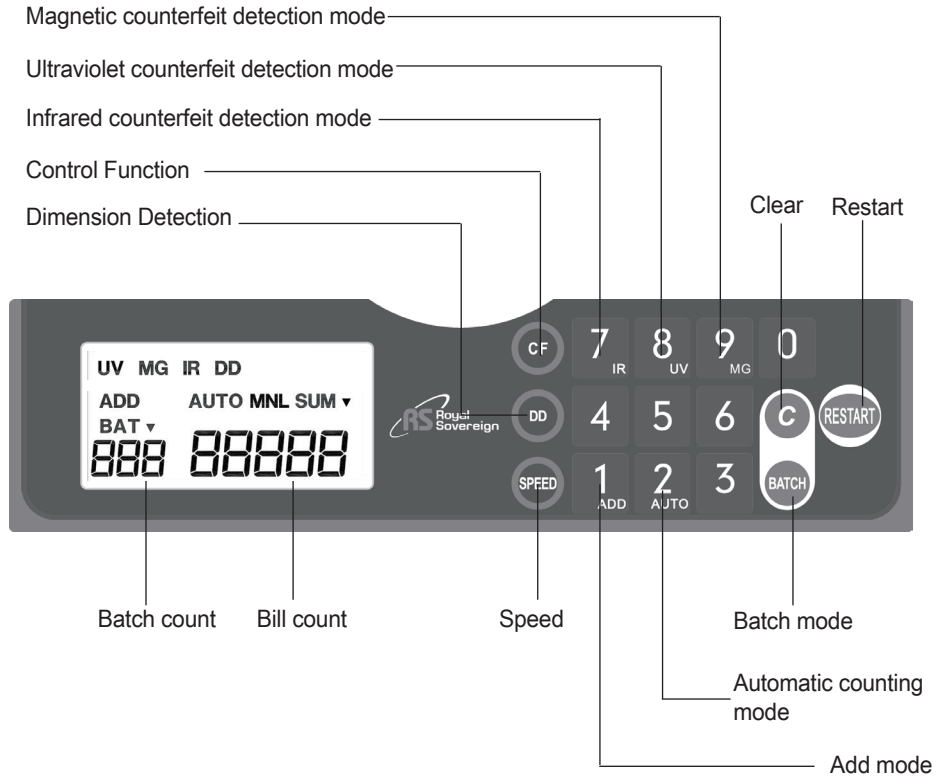

## FEATURES

### **Front Loading**

The sophisticated front loading system provides easy access to hopper, allows larger hopper capacity, and is more durable than a back loading system.

### **Automatic Self-Test**

The machine will automatically perform a self-test when it is turned on. If there is a problem, the preset display will show an error code. (See ERROR CODE DISPLAYS.)

### **Auto and Manual Start Modes**

The machine is preset to automatically start counting bills once placed into the hopper. To change to the manual start mode, press the CF button and then the AUTO button (#2 on the numeric keypad). MNL will appear on the display. Insert the bills into the hopper, and press the RESTART button. Press the CF button and then the AUTO button (#2 on the numeric keypad) to return to auto mode.

### **Magnetic Counterfeit Detection**

If the magnetic detector does not find the presence of magnetic components that are standard in authentic bills, the machine will stop counting to allow removal of the counterfeit bill and display the error code on the preset display. To use magnetic counterfeit detection press the CF button and then the MG button (#9 on the numeric keypad). Press the CF button and then the MG button (#9 on the numeric keypad) to disengage the MG function. When the MG detector finds a counterfeit bill, the machine will stop counting to allow removal of the counterfeit bill and display the error code on the preset display.

### **UV Counterfeit Detection**

Counterfeit bills often use white or bleached paper, which will glow under ultraviolet light. To use ultraviolet counterfeit detection press the CF button and then the UV button (#8 on the numeric keypad). Press the CF button and then the UV button (#8 on the numeric keypad) to disengage the UV function. When the UV detector finds a counterfeit bill, the machine will stop counting to allow removal of the counterfeit bill and display the error code on the preset display.

### **IR Counterfeit Detection**

Most bills often have infrared markings. Infrared light is used to validate these markings. To use infrared counterfeit detection press the CF button and then the IR button (#7 on the numeric keypad). Press the CF button and then the IR button (#7 on the numeric keypad) to disengage the IR function. When the IR detector finds a counterfeit bill, the machine will stop counting to allow removal of the counterfeit bill and display the error code on the preset display.

## Dimension Detection

The dimension detector measures the width of the center of each bill by using infrared light. If the detector finds an odd sized bill, the machine will stop counting to allow removal of the bill and display the error code on the preset display. To use dimension counterfeit detection press the DD button. (To adjust the DD level press the "DD" button for 3 seconds, the display will show the current size (dd- -5). Press the numeric key 1 to 9 to adjust the level, 1 for lowest, 9 for highest. After choosing the level number press the RESTART button to confirm .) To disengage this function press the DD button again.

## Operation

1. Attach power cable to back of machine, plug into a three prong outlet and turn power switch on. After five seconds the screen will display a "0" on the left and on the right of the display with the word "AUTO" above the zeros.
2. Select counterfeit detection mode.  
To use infrared (IR #7 on the numeric keypad), ultraviolet (UV #8 on the numeric keypad), or magnetic (MG #9 on the numeric keypad) counterfeit detection while counting press the CF key and then the corresponding detection method on the key pad.
3. For dimension detection select the "DD" button on the control panel.
4. Select bill counting settings

### Bill Counting Speed

Press the Speed button on control panel and continue to press the key until you come to speed setting you wish to use (800, 1,200, 1,600, 1,900)

### Add Mode

To continuously add totals for a cumulative total when counting press the CF key on the control panel then the ADD button on the keypad (#1 on the keypad). Pree the CF key then the ADD button to cancel the add mode.

### Batching Mode

To count bills in batches press the BATCH button on the control panel. Batching is preset to 10 bills. Additional presets for 20, 25, 50, and 100 can be accessed by continuing to press the BATCH button. You can also use the numeric keypad to enter a batch number between 1 and 999.

Press the clear button "C" to clear the batch setting.

### Auto/Manual Start Modes

The machine is preset to automatically start counting bills once they are placed in the hopper. To change to manual start mode press the "CF" key on the control panel and then the AUTO key on the numeric keypad (# 2 on the keypad). MNL should be displayed on the screen. (Note: when in manual mode with no batching the number of bills counted will move from the right of the display over to the left of the display when you start to count a new set of bills.) To return to AUTO mode press the CF key and the AUTO key (#2 on the keypad) AUTO will now be displayed on the screen.

## ERROR MESSAGES AND SOLUTIONS

When an error code appears in the preset display window and the machine stops, please refer to the following chart for an explanation

Error code	Messages	Solutions
UU	Suspicious bill detected by UV function;	Remove the suspicious bill from the stacker, press "RESTART" to continue;
		Remove all the bills from the stacker, press "RESTART" to continue;
	Problem with the UV function	Lower the UV sensitivity level
nng	Suspicious bill detected by MG function;	Remove the suspicious bill from the stacker, press "RESTART" to continue;
		Remove all the bills from the stacker, press "RESTART" to continue;
	Problem with the MG function	Lower the MG sensitivity level
dbl	Suspicious bill detected by IR function;	Remove all the bills from the stacker, press "RESTART" to continue;
	Problem with the IR function	Lower the MG sensitivity level
dd	Suspicious bill detected by DD function;	Remove all the bills from the stacker, press "RESTART" to continue;
		Remove all the bills from the stacker, press "RESTART" to continue;
	Problem with the DD function	Lower the DD sensitivity level
HALF	Half note	Remove all the bills from the stacker, press "RESTART" to continue;
CHN	Double note	Remove all the bills from the stacker, press "RESTART" to continue;
EAD	Problem with the right counting sensor.	Clean the sensor or replace it.
EAL	Problem with the left counting sensor.	Clean the sensor or replace it.

EA3	Problem with the the main motor and the control circuit	Replace the mian motor or the main board
	Problem with the drive belt	Replace the drive belt
	Problem with the feeding sensor or the control circuit	Replace the feeding sensor or the main board
EA2	Problem with the reset sensor or the control circuit	Replace the reset sensor or the main board

## SPECIFICATIONS

Model	RBC-5000
Voltage/AC/Current	100-240V 50-60Hz 1A
Power consumption	75W(Max)
Counting display	5 digit counting display
Counting speed	800 / 1,200 / 1,600 / 1,900 bills per minute
Batch range	1-999PCS
Banknote size	L:50~100mm(1.9 - 3.9 in) W:90~190mm(3.5-7.5 in)
Banknote thickness	0.075~0.15mm( 0.003-0.006 in)
Hopper capacity	300PCS
Stacker capacity	200PCS
Net weight	4.9kg(10.80 lbs.)
Dimension	250×230×255mm(9.8 x 9.1 x 10.0 in )

## LIMITED ONE YEAR WARRANTY

This warranty applies to repair or replacement of product found to be defective in material or workmanship for one year from the date of the original purchase. This warranty is extended only to the original purchaser.

This warranty does not apply to damage resulting from abuse, misuse, or improper maintenance of damage that is attributable to acts of nature. Royal Sovereign International, Inc. (and its affiliated companies) is not liable for incidental or consequential damages of any nature. This limitation would not apply if you live in those areas that do not permit the exclusion or limitation of incidental or consequential damages.

Defective products for warranty repair or replacement cannot be returned without a Return Authorization number. Please go to [www.royalsovereign.com](http://www.royalsovereign.com) USA-Customer Support Tab to make a request for an Office Product Return Authorization.

Defective products must be returned to Royal Sovereign International Consumer Return Department, freight prepaid, with proof of purchase and Return Shipping and Handling payment (check or money order). Upon repair or replacement the product will be returned to the customer.

Return defective product to the following address with a detailed description of the problem. If possible, pack in original carton. Please prepay shipping charges.

For out of warranty service or frequently asked questions please go to [www.royalsovereign.com](http://www.royalsovereign.com) USA- Customer Support Tab.

For sales of product, parts or accessories please visit us at [www.royalsovereign.com](http://www.royalsovereign.com).

For service or sales, please contact your local Royal Sovereign Office:

### **ROYAL SOVEREIGN INTERNATIONAL, INC.**

2 Volvo Drive Rockleigh, NJ 07647 USA

TEL : +1) 800-397-1025 FAX : +1) 201-750-1022

[www.royalsovereign.com](http://www.royalsovereign.com)

### **RS INTERNATIONAL CANADA INC.**

5610 Timberlea Blvd, Mississauga Ontario L4W 4M6 CANADA

TEL: +1) 905-461-1095 FAX: +1) 905-461-1096

TF: +1) 866 961-6673

[www.royalsovereign.ca](http://www.royalsovereign.ca)