



INSTALLATION, AND OPERATION MANUAL

Model: WLF-RO5

5 STAGE
REVERSE OSMOSIS SYSTEM



Thank you for purchasing the WLF-RO5 Reverse Osmosis (RO) water purification system

The WLF-RO5 is a 5 stage Reverse Osmosis system designed to reduce high amounts of contaminants found in municipal drinking water including Sediment, Chlorine Taste and Odor, Copper, TDS, Chromium, Fluoride, Lead, Mercury, Arsenic, Chromium, Cryptosporidium or Giardia.

Osmosis is achieved by forcing water through a semi permeable membrane allowing only pure water to pass through. The contaminants concentrate on the other side of the membrane and are eventually flushed down the drain.

This system has 5 separate treatment segments using 5 different filters. A sediment filter, GAC filter, carbon block, membrane and a post carbon filter.

Reverse Osmosis Stages and Filter Models				
Stages	Filter Type	Contaminant Reduction	Filter Life	Part Number
1	Sediment Filter (5 micron)	Removes sediment, dirt, silt and rust which affect the taste and appearance of your water.	6 Months	WFT-PP01
2	GAC Filter	Reduces Chlorine Taste and Odor	6 Months	WFT-GAC01
3	Carbon Block (5 Micron)	Reduces a high number of contaminants and protects the membrane from large particles	6 Months	WFT-CTO1
4	RO Membrane	Reduces a wide range of contaminants such as Perchlorate, Chromium, Arsenic, Copper and Lead as well as Cysts, Giardia and Cryptosporidium	1 Year	WFT-M50
5	In-Line Carbon Filter	This is a post filter helping to add a balanced taste to the water. It can also be referred to as a polishing filter.	6 Months	WFT-P33

System Maintenance

With proper installation and maintenance, this system will provide you with high quality water for years to come. Please Note: In order for this product to perform as intended, we recommended that you replace the carbon filters every 6 months or as instructed on this manual. Failure to do so could lead to a buildup of bacteria known as biofilm.

All of Water Filter Tree products are rigorously tested by an independent laboratory for safety and reliability.

If you have any questions or concerns, please send an email to info@waterfiltertree.com.

You can also purchase filter replacements via our online store: www.waterfilterjungle.com

Operational Parameters

Do not use with water that is micro-biologically unsafe or of unknown quality without adequate disinfection before or after the system. This system is intended to be installed on cold water lines only.

Voltage:	AC110V-DC24V
Maximum Water Generated:	50 Gal or 189 Kg
Pressure Tank Capacity:	3.2 Gal or 12Kg
Operating Temperatures:	Max: 100°F (37.8°C) – Min: 40°F (4.4°C)
Operating Pressure:	Max: 85 psi (6.0 kg/cm ²) – Min: 40 psi (2.80 kg/cm ²)
pH Parameters:	Maximum 11 - Minimum 2
Desalt Rate:	92-99%
TDS (Total Dissolved Solids)	< 1000 ppm
Turbidity	< 5 NTU

Hardness: Recommended hardness not to exceed 10 grains per gallon, or 170ppm. System will operate with hardness over 10 grains, but the membrane life may be shortened. The addition of a water softener may lengthen the membrane life.

Water Pressure: The operating water pressure in your home should be tested over a 24-hour period to attain the maximum pressure. If the incoming water pressure is above 85 psi a pressure regulator is recommended and if over 100 psi, then a pressure regulator is required.

Copper Tubing: Reverse Osmosis water should not be run through copper tubing as the purity of the water will leach copper causing an objectionable taste in the water, and pin holes may form in the tubing.

Contents of Reverse Osmosis (RO) System

- | | |
|-------------------------------------|-------------------------|
| 1 Tank | 1 Transformer |
| 1 RO Module (complete with filters) | 1 Parts Bag |
| 1 Pump - Installed | 1 Faucet Bag/Box |
| 1 Manual | 1 Filter Housing Wrench |

If any of the items are missing please contact Water Filter Tree customer support prior to installing.

System diagram

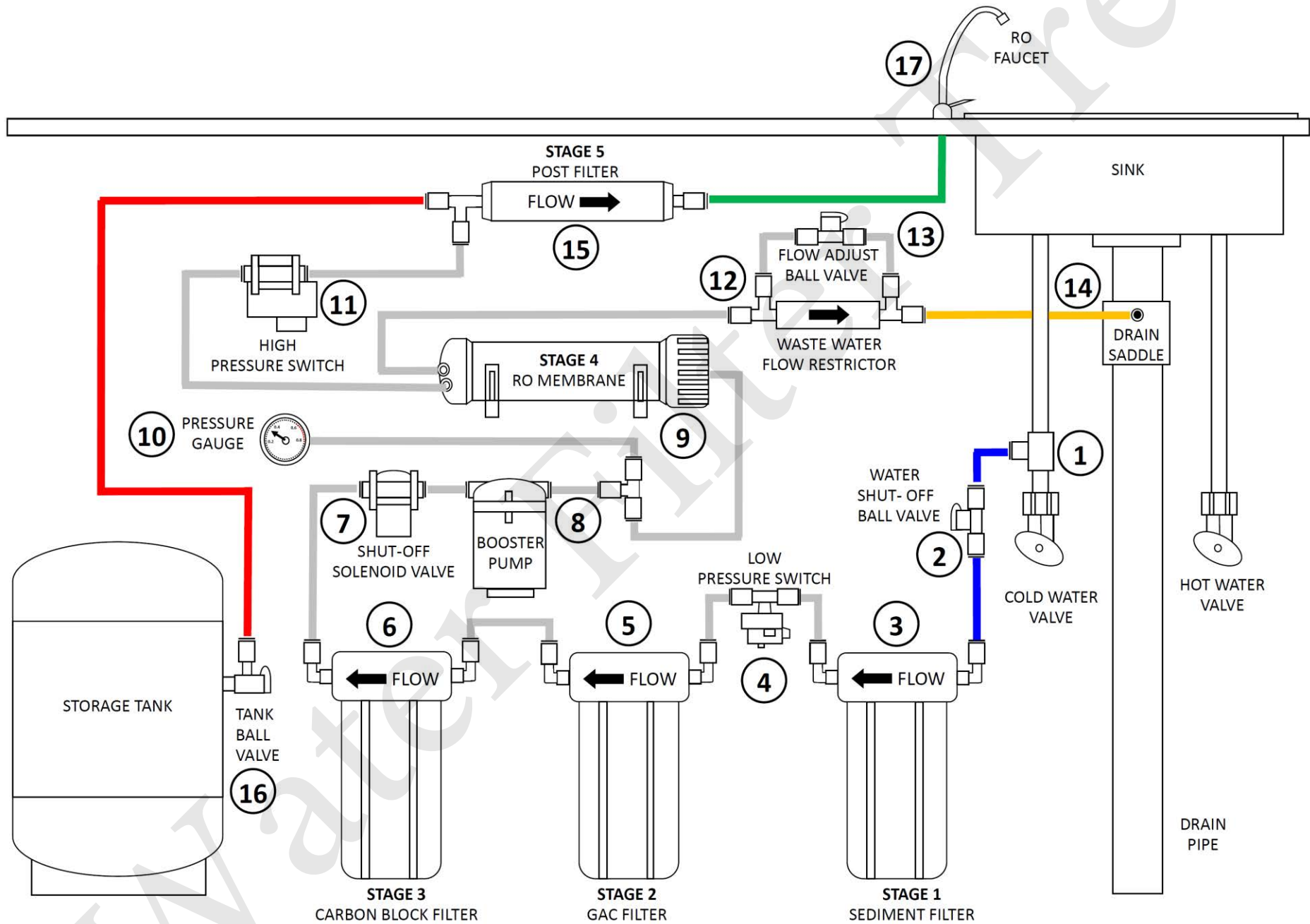

Parts List

Diagram Number	Part Name	Part Number	Description
1	Cold Water Valve	WFT-CWV01	Valve that fits onto the cold water supply line. The valve has a tube that attaches to the inlet side of the RO pre filter. This is the water source for the RO system.
2	Water Shut-Off Ball Valve	WFT-WSOBV02	Shuts off the mains water supply to the system
3	Clear Filter Housing	WFT-CFH03	Housing for the Sediment Filter
4	Low Pressure Switch	WFT-LPS04	Turns off the flow of water when water tank is full, switching off the pump
5	White Filter Housing	WFT-WHG05	Housing for the GAC Filter
6	White Filter Housing	WFT-WHC06	Housing for the Carbon Block
7	Shut-Off Solenoid Valve	WFT-SOSV07	When the system isn't being used it shuts off the mains water supply
8	Booster Pump	WFT-BP08	(24V-20W) Increases Water Pressure to the RO membrane
9	RO Membrane	WFT-M50	Removes contaminants such as calcium and magnesium that cause hard water as well as mineral salts, heavy metals such as lead, agrochemicals, protozoan bacteria, parasites, industrial chemicals and organic debris
10	Pressure Gauge	WFT-PG10	Measures the system's operating pressure
11	High Pressure Switch	WFT-HPS11	When the pressure in the tank reaches 2.5Kg/cm ² , it turns off the power supply to the pump and the membrane stops generating water.
12	Wastewater Flow Restrictor	WFT-WFR12	Maintains the flow rate required to obtain the highest quality drinking water (based on the gallon capacity of the membrane). It also helps maintain pressure on the inlet side of the membrane. Without the flow control very little drinking water would be produced because all the incoming tap water would take the path of least resistance and simply flow down the drain line. The flow control is located in the RO drain line tubing.
13	Flow Adjust Ball Valve	WFT-FABV13	Manually adjusts the amount of waste water passing through the flow restrictor
14	Drain line and Saddle	N/A	This line runs from the Wastewater Flow Restrictor to the drain. This line is used to dispose of the impurities and contaminants filtered by the membrane. (Saddle not included)
15	Post Filter	WFT-P33	After the water leaves the RO storage tank, but before going to the RO faucet, the product water goes through the post filter through a carbon block. Any remaining tastes and odors are removed from the product water by post filtration
16	Storage Tank	WFT-ST16	The storage tank holds up to 2.5 gallons of water. A bladder inside the tank keeps water pressurized in the tank when it is full.
17	Faucet	WFT-FAU01	The RO unit uses its own faucet, which is usually installed on the kitchen sink. Some areas have plumbing regulations requiring an air gap faucet, but non-air gap models are more common

Faucet Installation

WARNING: Serious cracking and damage may occur to your sink even if instructions are followed exactly due to age and the imperfections inherent in natural materials. Instructions may not apply exactly to your sink. Use caution – sink may be slippery.



Note: Most sinks are pre drilled with 1 ¼" diameter hole that you can use for your RO faucet.



1. Locate a suitable place in your sink to install your RO faucet (17) and place a piece of masking tape over where the hole will be drilled. Mark the center of the hole on the tape.
2. Drill a 1/8" pilot hole through the marked center of the desired location of the sink with a variable speed drill set, on the slowest speed. If drilling through a porcelain sink, use a lubricant liquid soap to keep the drill bit cool to prevent the sink cracking or chipping.
3. Using the pilot hole as a guide, drill a larger hole using a 1 ¼" diamond tip hole saw on the slowest speed setting, lubricating as you go, to keep the hole saw cool during drilling.
4. After drilling, sand any sharp edges prior to mounting the faucet.

5. To install the faucet (17), feed the hose (green on the diagram) through the drilled hole on the sink.
6. Before installing the faucet, first attach the **Hose Connector, Anti-Slip Plastic Ring** and the **Plastic Sleeve**, to the hose, as shown on the diagram (Fig.1.2)

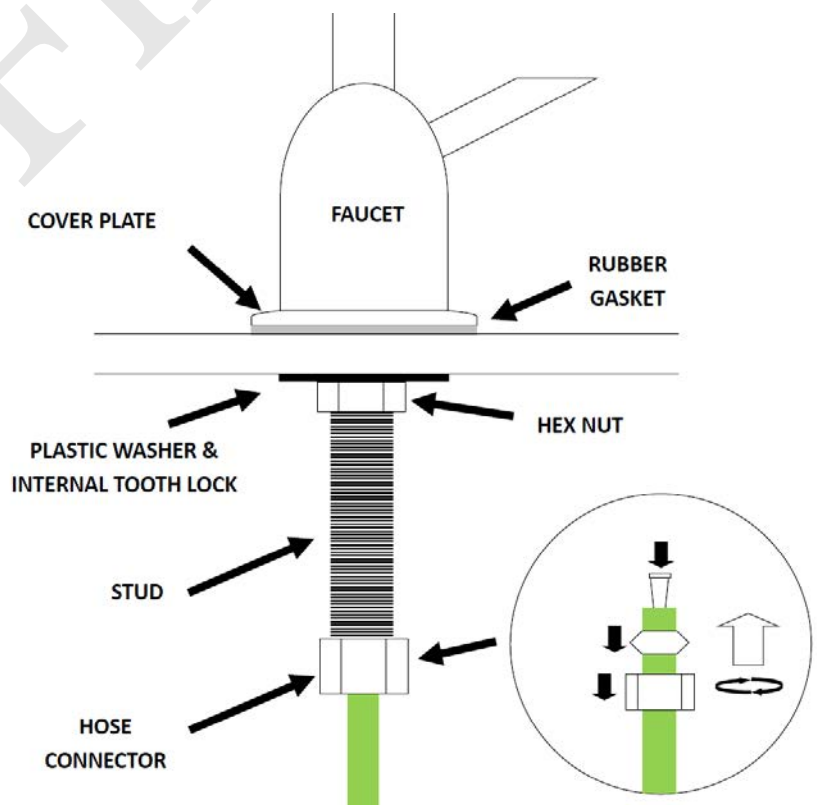

7. Slide the fixing plate and the rubber gasket up the stud until it reaches the bottom of the faucet.
8. Then slide the faucet into the hole, so the stud protrudes on the underside of the sink.
9. Slide the plastic washer followed by the lock washer and secure it with the nut provided.
10. Attach the Hose Connector to the end of the stud twisting counter-clockwise until is tightly secured.

Cold Water Valve Installation

Caution: Water supply line to the system must be from the cold water supply line only. Hot water will severely damage your system.

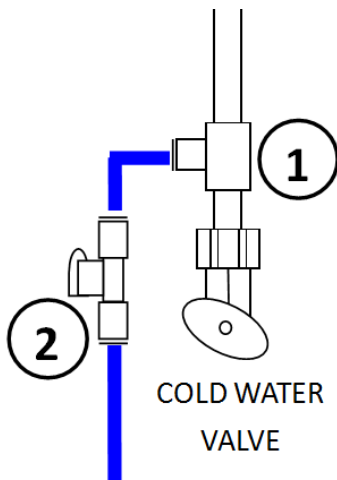

- Turn off the cold water supply to the faucet by turning the cold water valve completely off.
- Open cold water sink faucet to relieve pressure.
- Attach the 3-way valve to the cold water supply ① making sure that they are connected to the 3/8" openings.

Caution: Under sink piping can vary, especially in older homes. If you have a brass 1/2" piping, it will require a different adaptor. If in doubt you should contact your local plumber.

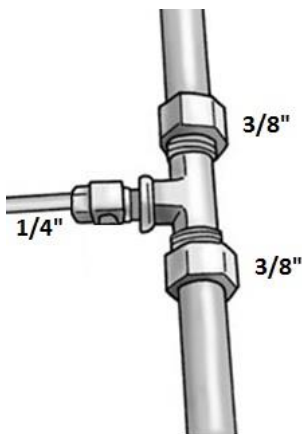

- To make a connection, the 3/8" tubes are simply pushed into the fitting. The unique locking system holds the tube firmly in place without deforming it or restricting flow.

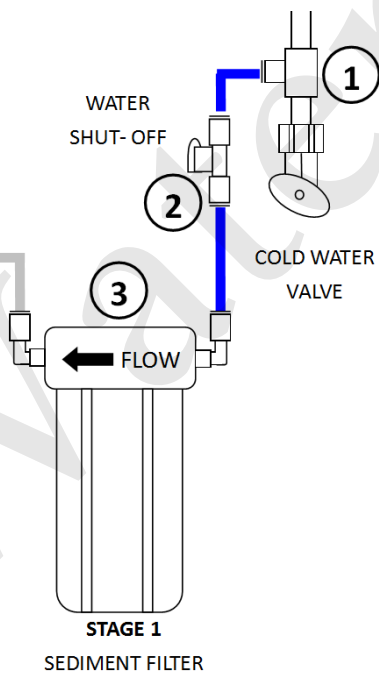
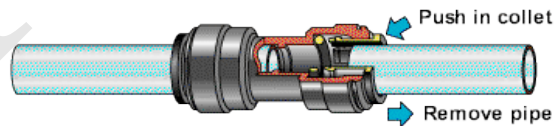

- Cut the 1/4" RO tube supplied that attaches to the inlet side of the RO pre filter ③ to install the Water Shut-Off Valve ②.
- This valve will help switching the supply of water to the RO system whilst keeping supply to the main sink.



Drain Saddle Installation

Drain Saddle (Not Supplied) should fit standard 1 ¼" – 1 ½" drain pipes

Caution: If you have a garbage disposal, do not install the drain saddle near it. Installation of the drain saddle must be either above the garbage disposal, or if a second sink drain is available, install it above the cross bar on the second drain.

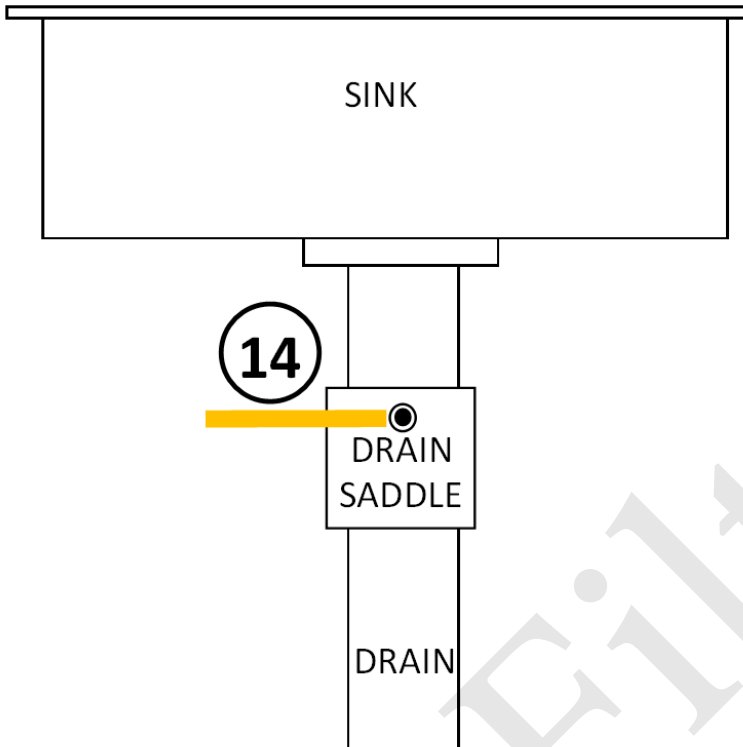

- Choose a suitable location on the drain pipe to drill the RO waste water drain hole.

Caution: The drain saddle ⑭ must be mounted at least 1 ½" above the nut of the P-trap or cross bar from the garbage disposal to insure proper drainage.

- Prior to drilling place a strip of tape on the chosen location, to avoid the drain pipe damaging during drilling.
- Assemble the drain saddle around the drain pipe. Using a screw driver tighten screws evenly and securely on both sides of the drain saddle.
- With the drain saddle secured onto the drain pipe, use a ¼" drill bit installed in your electric drill and insert the drill bit through the opening in the drain saddle and drill into the drain pipe.

Caution: In order to prevent damage of to drain saddle while drilling, it's is very important to keep the drill centered.

- Insert the ¼" tube into the opening in the drain saddle and hand tighten the nut with a ¼" wrench.

Important: When inserting the ¼" pipe into the drain saddle make sure is not pushed in right to the end, as this may prevent the water from draining properly.

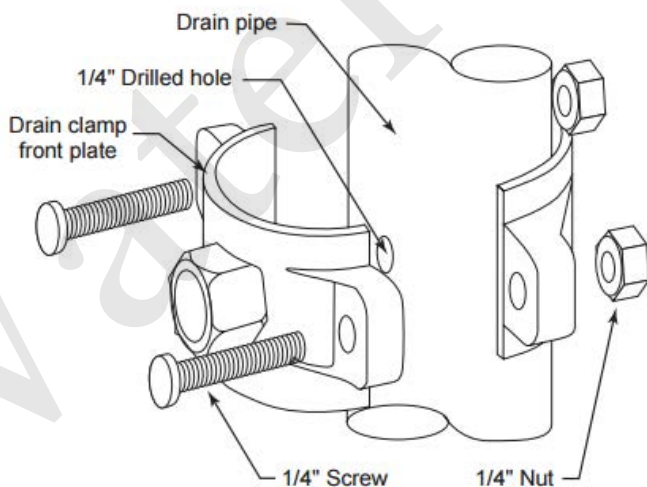

Main Connections Installation

Diagram

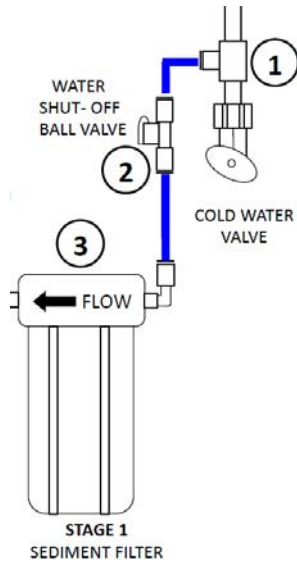

Input



Instructions

Having installed the cold water feed and the Water Shut-Off Valve (2), you will now need to connect a 1/4" pipe between the Water-Shut Off Valve (2) and the Stage 1 Sediment Filter Housing (3) input shown in Blue (Feed Water IN).

The Water Shut-Off Valve (2) has a quick connect push fitting and the RO feed Input has a Screw Fitting. For the Stage 1 housing Input, unscrew the cap of the connector and insert the 1/4" pipe through the cap into the connector. Screw the cap back on, to secure.

Next, connect the Faucet input pipe (already installed, see faucet installation) to the Green output located at the Stage 5 Post Filter (No.15) marked "Tap Faucet OUT".

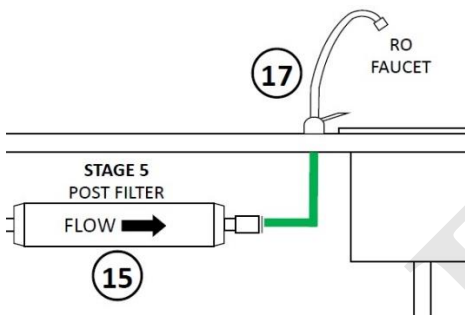

For the Stage 5 output, unscrew the cap of the connector and insert the 1/4" pipe through the cap into the connector. Screw the cap back on, to secure.

Next is the Storage tank connection. First screw the Tank Ball Valve (16) supplied to the Storage Tank until it is tightly secured. Then connect the remaining 1/4" pipe from to the Storage Tank to the Stage 5 Post Filter (15) Red Output marked "Storage Tank Out". **Note:** Both connectors are screw fittings. To connect, simply unscrew the cap of the connector and insert the 1/4" pipe through the cap into the connector. Screw the cap back on, to secure.

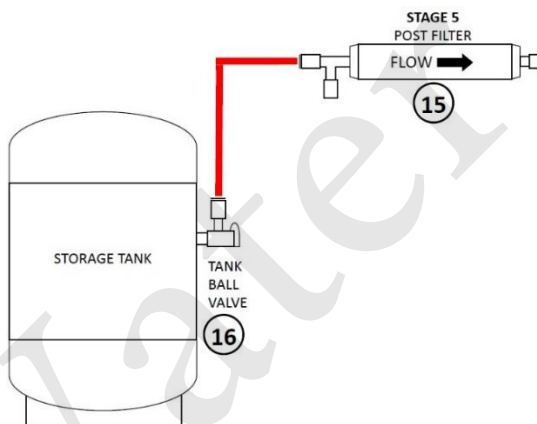

The final connection is the waste water connection. Simply connect one hose to the Waste Water Flow Restrictor. This has a quick connect tube fitting. And the other end to the drain saddle (see Drain Saddle Installation section)

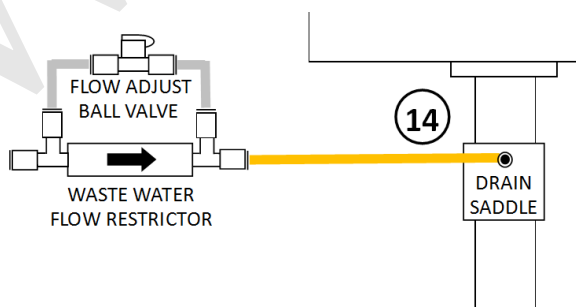

Starting up the Unit

Warning: To prevent the possibility of electrical shock, clean up any water under the sink and around the RO System with a dry cloth.

Note: This unit has a built in Booster Pump, Solenoid Valve, and Pressure Switch and therefore no further component installation is required.

1. Turn on the cold water valve.
2. Check for any leaks around the machine including the Cold Water supply ①, Water Shut-Off Valve ②, Tank Ball Valve ⑬, Stage 5 Post Filter ⑮ (Tap Faucet OUT & Storage Tank Out) and Faucet ⑰
3. Once you have checked for leaks, plug the RO unit into the electrical outlet under the sink.
Note: If the RO system does not turn on, check the power outlet. Is possible that this outlet is controlled by the garbage disposal switch. Flip the switch and see if you can hear the RO pump.
4. Make sure ball valve on the storage tank is open.
5. Open the RO faucet and leave it open until the water begins to drip and then close it. The tank will take between 2 - 4 hours to fill.

Note: During this time keep on checking for possible leaks.

6. After the tank has filled completely, open the RO faucet and drain the tank.

Note: At this stage the water may come out looking cloudy due to air being trapped in the system. You may also find carbon particles coming from the polishing filter. This is normal and it will go away after flushing a couple of tanks of water.

7. Let the tank fill up again and repeat step 6.

6 Month Maintenance

1. First you will need the following consumable part numbers and quantities:
 - 1 x Sediment Filter – Part Number: WFT-PP01
 - 2 x CTO Carbon Block filters (5 Micron) – Part Number/s: WWC105 or WFT-CTO1
2. Close the RO Storage Tank Ball Valve ⑬ and open the faucet ⑰.
3. Turn off the Water Shut-Off Valve ②.
4. Turn off the electrical power.
5. Using the filter wrench provided, open the filter housings ③, ⑤, ⑥ starting with Stage 1, ③ on the diagram. Remove the housing carefully by turning it clockwise, being careful not to spill the water inside the housing. Once the housing is removed, discard the water and filter.
6. Repeat the process for filter housings ⑤, ⑥. Stage 2 and Stage 3.
7. Insert the Sediment filter (Part: WFT-PP01) into the Stage 1 housing ③. Make sure the housing O-Ring is still in place before tightening.
8. Insert the Carbon filter (Part: WWC105) into Stage 1 and Stage 2 housings ⑤, ⑥. Again making sure

the O-Ring is still in place before tightening.

9. Once all the filters are installed, make sure there is no water on or around the unit. Dry the surfaces with a dry cloth. **Caution:** Failure to do this may result in electric shock, bodily injury, fire, product failure, or damage
10. Turn on the electrical power.
11. Turn on the Water Shut-Off Valve ②
12. Close the RO faucet and open the RO Storage Tank Ball Valve ⑩. Your RO System is now ready to use.

Yearly Maintenance

Note: If you are disinfecting the system, please see notes in the next page

1. First you will need the following consumable part numbers and quantities:
 - 1 x Sediment Filter – Part Number: WFT-PP01
 - 2 x CTO Carbon Block filters (5 Micron) – Part Number/s: WWC105 or WFT-CTO1
 - 1 x Membrane (Recommended) – Part Number: WFT-M50
 - 1 x Post Filter – Part Number: WFT-P33
2. Close the RO Storage Tank Ball Valve ⑩ and open the faucet ⑪.
3. Turn off the Water Shut-Off Valve ②
4. Turn off the electrical power.
5. Using the filter wrench provided, open the filter housings ③, ⑤, ⑥ starting with Stage 1, ③ on the diagram. Remove the housing carefully by turning it clockwise, being careful not to spill the water inside the housing. Once the housing is removed, discard the water and old filter.
6. Repeat the process for filter housings ⑤, ⑥. Stage 2 and Stage 3.
7. Insert the new Sediment filter (Part: WFT-PP01) into the Stage 1 housing ③. Make sure the housing O-Ring is still in place before tightening.
8. Insert the new Carbon filter (Part: WWC105) into Stage 2 and Stage 3 housings ⑤, ⑥. Again making sure the O-Ring is still in place before tightening.
9. Remove the Stage 4, RO membrane ⑨ by using the wrench provided. Before you do this, you will need to disconnect the water inlet tube situated on the cap of the membrane housing. The tube is connected with a quick release connector. Discard the old membrane and replace with the new one (Part Number: WFT-M50).
10. Finally, you will need to replace the Post Filter ⑫, Stage 5 (Part Number: WFT-P33). The filters have a connector attached to either side of the filter. First disconnect the outlet tube from the filter connector that goes to the faucet (green tube on the RO diagram). This connector uses a screw connection. Do not remove from faucet side.

Note: There is no need to disconnect the water inlet tubes going into the Post Filter.

Once the tube is disconnected from the outlet connector that is attached to the filter, simply twist the filter to unscrew the inlet connector attached to the filter. Once the inlet connector is detached from the filter, unscrew the outlet connector from the filter in the same way. Discard old filter. Attach the connectors to the new filter in the same order as they were disassembled.

11. Turn on the electrical power.
12. Turn on the Water Shut-Off Valve ②
13. Close the RO faucet and open the RO Storage Tank Ball Valve ⑩. Your RO System is now ready to use.

Sanitizing the Equipment

1. If sanitizing the unit, remove all the old filters (Stage 1, 2, 3, 4) from their housings and discard leaving the inline filter (Stage 5) in place. Please see the Yearly Maintenance Section on how to remove housings and filters.
2. Screw the housings back on (Stage 2, 3 and 4) to the unit by hand. Don't use the wrench.
3. Pour 1/2 cup of hydrogen peroxide or common household bleach into the first housing Stage 1 and screw the housing back on (hand tight).
4. Open the RO Storage Tank Ball Valve and close the faucet ⑩
5. Turn on the Water Shut-Off Valve ②, switch the unit on and let it pressurize for around 2 minutes.
6. Once pressurized, turn the RO faucet on for 1 minute. Close the faucet and wait for 2 minutes.
7. Once the 2 minutes have passed, open the faucet once more time and let it run for 5 minutes.
8. With the faucet still open switch the unit off and turn off the Water Shut-Off Valve ②.
9. Wait until the storage tank is completely drained.
10. Unscrew the housings (Stage 1, 2, 3) and drain the water.
11. Remove the Post Filter ⑮, Stage 5 (Part Number: WFT-P33). The filters have a connector attached to either side of the filter. First disconnect the outlet tube from the filter connector that goes to the faucet (green tube on the RO diagram). This connector uses a screw connection. Do not remove from faucet side.

Note: There is no need to disconnect the water inlet tubes going into the Post Filter.

Once the tube is disconnected from the outlet connector that is attached to the filter, simply twist the filter to unscrew the inlet connector attached to the filter. Once the inlet connector is detached from the filter, unscrew the outlet connector from the filter in the same way. Discard old filter. Attach the connectors to the new filter in the same order as they were disassembled.
12. Insert the new Sediment filter (Part: WFT-PP01) into the Stage 1 housing ③. Make sure the housing O-Ring is still in place before tightening.
13. Insert the new Carbon filter (Part: WWC105) into Stage 2 and Stage 3 housings ⑤, ⑥. Again making sure the O-Ring is still in place before tightening.
14. Insert the new RO membrane ⑨ Stage 4. (Part Number: WFT-M50).
15. Turn on the electrical power.
16. Turn on the Water Shut-Off Valve ②
17. Close the RO faucet and open the RO Storage Tank Ball Valve ⑩.
18. Once the storage tank is full, open the faucet and drain the storage tank. Repeat this 3 times.
19. Your RO System is now ready to use.

Checking Air Pressure in the Tank

Note: If you notice a decrease in available water from the RO system, check the air pressure in the storage tank. You can add air with a bicycle pump using the schrader valve that is located on the bottom of the tank behind a black plastic cap.

1. Turn off the Water Shut-Off Valve ②, switch the unit off.
2. Turn the faucet on and drain the water in the tank.
3. Once the tank is completely drained (water slows to a trickle) check the air using a pressure gauge.
4. Pressure should read 5-7 PSI.
5. If pressure is low use the bicycle pump to increase the pressure.

Caution: In order for this product to perform as intended, Operation and maintenance and filter replacement must be carried as scheduled

Warning: To reduce the risk associated with the indigestion of contaminants: Do not use with water that is microbiologically unsafe or of unknown quality without adequate disinfection before and after the system

For more information about the benefits of RO filtration please visit www.waterfiltertree.com

Please refer to this manual for proper maintenance and operated as specified in this owner's manual, there is a risk of exposure to contaminants

Water Filter Tree is a Trademark of Vectornate USA Inc. All Rights reserved.

Customer Service: info@waterfiltertree.com

