

SZ10-ZN/EN-A01

CREATOR PRO

User Guide

Contents

Preface Introduction Notice

Chapter 1: 3D Printing Technology Process Make a 3D Model / Slice and Export the 3D Model / Build the 3D Model	05
Chapter 2: About Creator Pro About Your Creator Pro Views / Accessories / Terms / Parameters	06
Chapter 3: Unpacking	09
Chapter 4: Hardware Assembly	12
Chapter 5: Build Plate Leveling	17
Chapter 6: About Software Software Installation Software Acquisition / Software Installation and Start-up Exploring FlashPrint	19
Chapter 7: Basic Printing Generate a Gcode Loading / Unloading the Filament Using LCD Panel	31
Chapter 8: Function	35
Chapter 9: Supports and Service	35

Preface

Note: Each device must be tested before leaving factory. If there are some residues in extruder or some tiny scratches on the build tape, it is normal and won't affect the printing quality.

On the completion of this User Guide, thanks all Flashforge engineers and the Flashforge 3D printer users for their unremitting efforts and sincere assistance.

The Flashforge Creator Pro User Guide is designed for the Creator Pro users to start their printing journey with Flashforge Creator Pro. Even if you are familiar with earlier Flashforge machines or 3D printing technology, we still recommend that you read through this guide, as there is lots of important information about the Creator Pro for you to get a better 3D experience.

For a better and more successful printing experience, you can refer to the following materials:

(1) Quick Start Guide

Users will find the Quick Start Guide together with the printer accessories. The Quick Start Guide will help you start your print journey as soon as possible.

(2) Official Flashforge Website: www.flashforge.com

The official Flashforge website contains the up-to-date information concerning Flashforge software, firmware, device maintenance and so on. Users are also able to get the contact information from there.

Introduction

- ◆ Please read Flashforge Creator Pro 3D Printer User Guide carefully before use.

The Flashforge Creator Pro 3D Printer User Guide contains the information needed for you to set up and use this device.

This User Guide includes the following parts: Preface, Introduction and after-sale service.

The Preface section includes resource acquisition channel, the overall framework of the manual, and the problems that should be paid attention to.

The introduction section contains the presentation of 3D printing technology, equipment introduction, unpacking and installation of equipment, software installation and usage.

After-sale section tells the user how to get the support and help.

Notice

Notices: Read all the instructions in the manual and familiarize yourself with the Flashforge Creator Pro User Guide before setting-up and using. Failure to comply with the warning and instructions may result in individual injury, fire, equipment damage or property damage.

PLEASE STRICTLY FOLLOW ALL THE SAFETY WARNINGS AND NOTICE BELOW ALL THE TIME.

Work Environment Safety

- ◆ Keep your work place tidy.
- ◆ Do not operate Creator Pro in the presence of flammable liquids, gases or dust.
- ◆ Creator Pro should be placed out of children and untrained people's reach.

Electricity Safety

- ◆ Always use the Creator Pro with a properly grounded outlet. Do not refit Creator Pro plug.
- ◆ Do not use Creator Pro in damp or wet locations. Do not expose Creator Pro to burning sun.
- ◆ In case of device damage, please use the power supply provided by Flashforge.
- ◆ Avoid using the device during a thunderstorm.
- ◆ In case of uncertain accident, please unplug the device if you do not use it for long.

Personal Safety

- ◆ Do not touch the nozzle and build plate during printing.
- ◆ Do not touch the nozzle after finishing printing.
- ◆ Dress properly. Do not wear loose clothing or jewelry. Keep your hair, clothing and gloves away from moving parts.
- ◆ Do not operate the device while you are tired or under the influence of drugs, alcohol or medication.

Cautions

- ◆ Do not leave the device unattended for long.
- ◆ Do not make any modifications to the device.
- ◆ To lower the build plate before loading/unloading filament. (The distance between the nozzle and build plate should be kept for at least 50mm)
- ◆ Operate the device in a well-ventilated environment.
- ◆ Never use the device for illegal activities.
- ◆ Never use the device to make any food storage vessels.
- ◆ Never use the device to make any electrical appliance.
- ◆ Never put the model into your mouth.
- ◆ Do not remove the models with force.

Environment Requirements

- ◆ Temperature: RT 15-30°C
- ◆ Moisture: 20%-70%

Filament Requirements

Do not abuse the filament. Please make sure you use the Flashforge filament or the filament from the brands accepted by Flashforge.

Filament Storage

All polymers degrade with time. Do not unpack until filament is needed. Filament should be stored in clean and dry conditions.

Legal Notice

All the information in this document is subject to any amendment or change without the official authorization from Flashforge.

FLASHFORGE CORPORATION MAKES NO WARRANTY OF ANY KIND WITH REGARD TO THIS DOCUMENT, INCLUDING, BUT NOT LIMITED TO, THE IMPLIED WARRANTIES OF MERCHANTABILITY AND FITNESS FOR A PARTICULAR PURPOSE.

Flashforge shall not be liable for errors contained herein for incidental consequential damages in connection with furnishing, performance or use of this material.

This document contains proprietary information protected by copyright.
Copyright © 2017 Flashforge Corp. All Rights Reserved

Chapter 1: 3D Printing Technology

3D printing refers to transforming three-dimensional models into physical objects that you can hold and touch. It is also called additive manufacturing because the 3D model is created by “adding” layers upon layers of material until the object is fully formed.

Fused Filament Fabrication(FFF) is the most common method of 3D printing. It is also the method that the Creator Pro uses. It works by melting plastic material called filament onto a print surface in high temperature. The filament solidifies after it cools down, which happens instantaneously after it is extruded from the nozzle. 3D objects are formed with the filament laying down multiple layers.

1.1 Process

3D printing involves three steps:

1. Make or download a 3D model.
2. Slice and export the 3D model.
3. Build the 3D model.

1.1.1 Make a 3D Model

Currently, there are three ways of creating a 3D model.

Designing From Scratch: You can use free CAD (computer-aided design) software such as 3DTADA, AutoCAD, SolidWorks, Pro-E, and our own software Happy 3D to design your own 3D model.

3D Scanners: An alternative method to creating a 3D model is to scan an object. 3D scanners work by digitizing a physical object, collecting its geometric data, and saving it to a file on your PC. There are also apps that can turn a mobile device into a 3D scanner.

From the Cloud: The most popular way of obtaining a 3D model is to download it from websites that allow users to upload 3D models that they designed.
E.g.: www.thingiverse.com

1.1.2 Slice and Export the 3D Model

Slice software is the software that prepares 3D models for printing and turns them into instructions for the 3D printers. FlashPrint is the slicing software used for the FlashForge Creator Pro.

Using FlashPrint, you can prepare stl. files to be x3g files for printing. Then users can print files via SD card.

1.1.3 Build the 3D Model

Once the output file has been transferred to your Creator Pro, it will start to turn the 3D model into a physical object by laying down layers of filament.

Chapter 2: About Creator Pro

2.1 About Your Creator Pro

2.1.1 Views

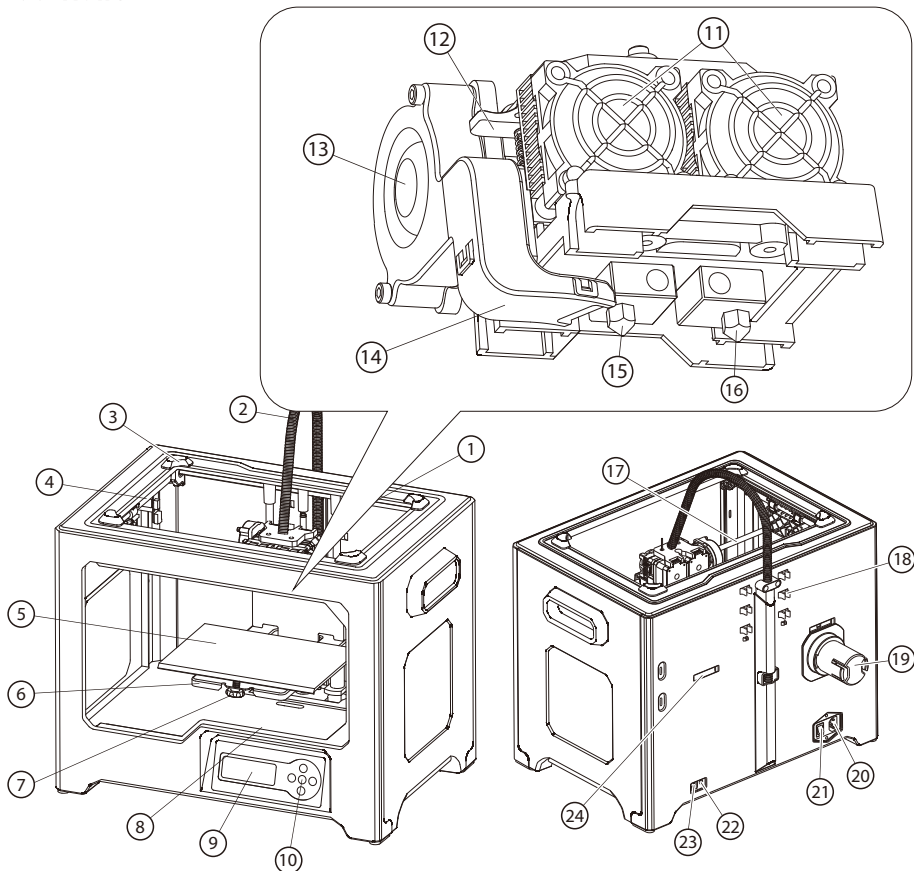

- | | | | |
|-----------------------|--------------------------------|------------------|---------------------|
| 1. Z-Axis Guide Rod | 2. Extruder Cable Bunch | 3. Slot | 4. Y-Axis Guide Rod |
| 5. Build Plate | 6. Build Platform | 7. Leveling Knob | 8. SD Card Slot |
| 9. LCD Panel | 10. Buttons | 11. Cooling Fan | 12. Spring Presser |
| 13. Turbofan | 14. Turbofan Baffle | 15. Left Nozzle | 16. Right Nozzle |
| 17. X-Axis Guide Rod | 18. Filament Guide Tube Buckle | 19. Spool Holder | |
| 20. Power Input | 21. Power Switch | 22. Reset Button | |
| 24. Spool Holder Slot | | 23. USB Input | |

2.1.2 Accessories

Along with your Creator Pro 3D printer, the box also contains the followings:

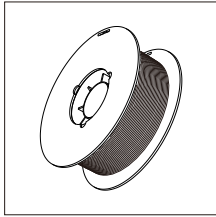

Filament Spool x 2

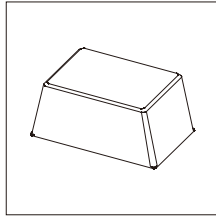

Lid



After-sales Service Card



Quick Start Guide

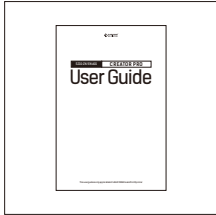

User Guide

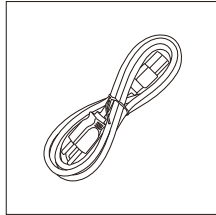

Power Cable

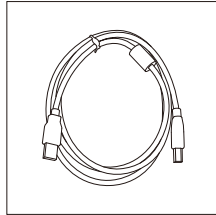

USB Cable

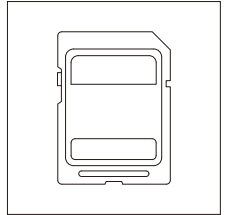

SD Card

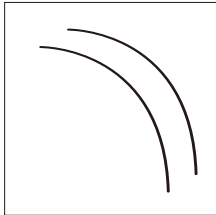

Filament Guide Tube x 2

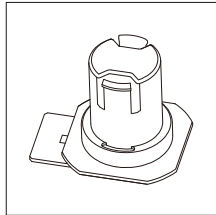

Spool Holder x 2

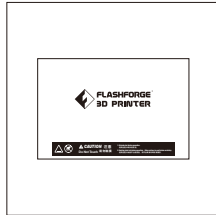

Build Tape x 2

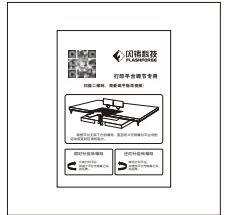

Leveling Card



Tool Bag



Extruder's
Accessory Kit

Tool bag:

(Allen Wrench X 2 / Leveling knob X 1 /
M3X8 Bolt X 2 / PTFE Tube X 2 / Grease X 1)

Extruder's accessory kit:

(M3X8 Bolt X 2 / M3X6 Bolt / Turbofan baffle)

2.1.3 Terms

Build Plate	The surface on which the Creator Pro builds an object.
Build Tape	The blue tape that covers Creator Pro's build plate so that the object can adhere to the build plate well.
Build Volume	The three dimensional amount of space that an object will use once it is completed. The largest build volume of Creator Pro is 227*148*150 mm.
Leveling Knobs	Knobs under the build platform that are used for adjusting the distance between the nozzle and build plate.
Extruder	The device that draws the filament from the spool, melts it and pushes it through a nozzle onto the build plate.
Nozzle	Also called "print head", which located at the bottom of the extruder where heated filament is squeezed out.
Cooling Fan	To cool the outer assembly of the extruder and gear motor.
Filament Intake	An opening located at the top of the extruder.
Filament Guide Tube	A plastic piece that guides the filament from the filament box to the filament intake.
Glue Stick	A solid adhesive used for making the model stick to the build plate firmly.
Unclogging Pin Tool	A tool that used for cleaning the extruder.
Stamping Wrench	A tool that used for seizing the nozzle's metal cube.

2.1.4 Parameters

Number of Extruder: 2	Software: FlashPrint
Print Technology: Fused Filament Fabrication(FFF)	Support Formats: Input: 3MF/STL/OBG/FPP/PNG/ JPG/JPEG Output:X3G
Screen: LCD Panel	OS: Win xp / Vista/7/8/10 / Mac OS / Linux
Build Volume: 227*148*150mm	Device Size: 526*360*403(550)mm
Layer Resolution: 0.05 - 0.4mm	NET Weight: 14.8Kg
Build Precision: ±0.2mm	AC Input: 100V-240V/4.5A-2.5A
Positioning Precision: Z axis 0.0025mm; XY axis 0.011mm	Connectivity: USBCable, SD Card
Filament Diameter: 1.75mm(±0.07)	
Nozzle Diameter: 0.4mm	
Build Speed: 10~200 mm/s	

Chapter 3: Unpacking

3.1 About Your Creator Pro

(Reference video: Creator Pro Unpacking)

The Creator Pro was carefully packaged at FLASHFORGE manufacturing facility. Please follow the unpacking steps laid out below.

⚠ CAUTION

1. Handle the package and its contents with extra care; do not use any unnecessary force.
2. Do not remove the wrapping around the nozzle. It consists of a ceramic fiber fabric and heat resistant tape that helps to keep the nozzle at a constant temperature.



1. Open box and remove top foam piece.



2. The foam should contain: two filament guide tubes, one piece of build tape, one Flashforge leveling card, one user guide and one Quick Start Guide.



3. Firmly grasp the two side handles of Flashforge Creator Pro. Lift it out from the carton and place it on a stable surface.



4. Remove the packing bag. And then remove the tape and plastic wrap for protecting the front door.

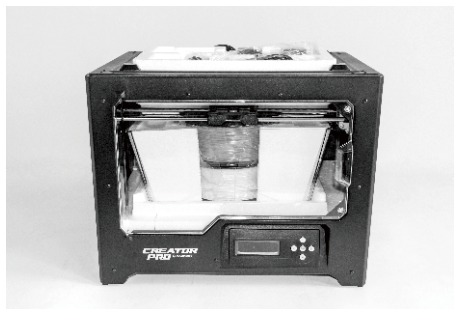

5. The Flashforge Creator Pro and its accessories shall be displayed in front of you.

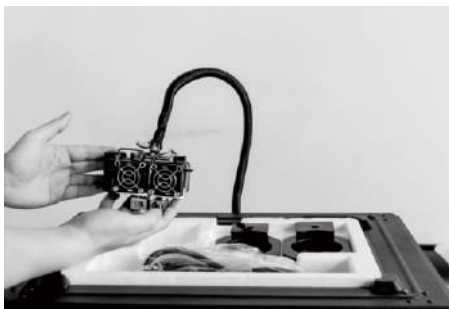

6. Take the dual extruder out and place the extruder carefully because the extruder cable bunch is short.



7. Remove the foam container. It should contain: power cable, USB cable, two spool holders, SD card, tool bag, extruder's accessory kit.



8. Slide the X-axis Rods to the very back.



9. Remove lid, which should hold two rolls of filament.

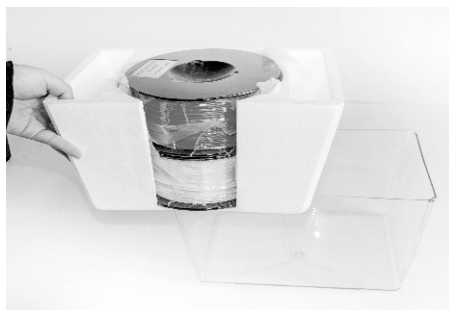

10. Take the two rolls of filament out from the lid.

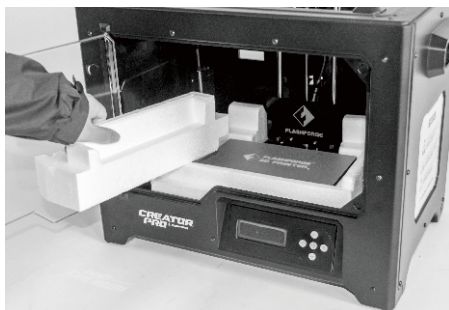

11. Remove side protective foam sheets from inside the printer.



12. Elevate the build plate to its limit with care.

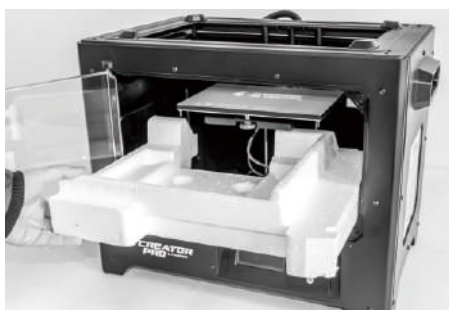

13. Take the bottom protective foam from the printer and then lower the build plate back.



14. Congratulations! You've finished the unpacking process. (Tip: Save your Flashforge Creator Pro packaging for future transportation and storage.)

Chapter 4: Hardware Assembly

Extruder Assembly

1. Place the dual extruder on the extruder seat.
2. Take the M2.5 Allen Wrench from the tool bag and two M3 x 8 bolts(longer ones) from the extruder's accessory kit.
3. Adjust the extruder location to align the bolt holes.
4. Secure the extruder onto the extruder seat by screwing the M3 x 8 bolts in.

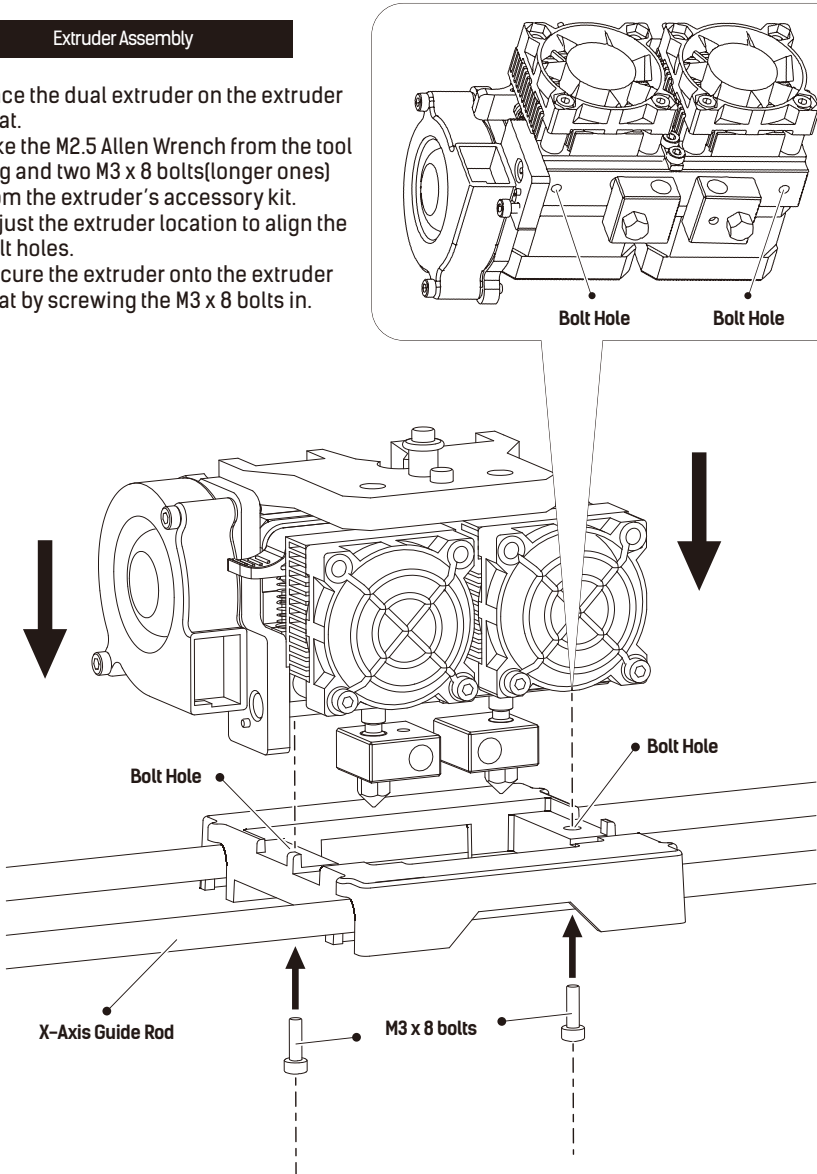

Turbofan Baffle Assembly

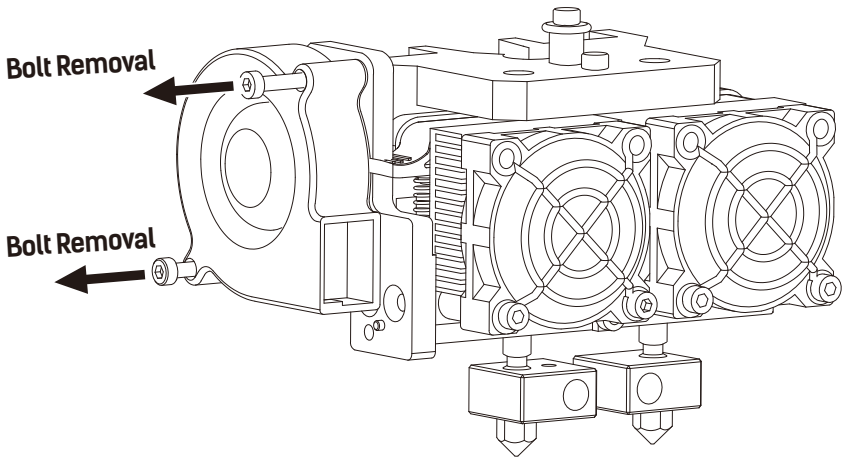

1. Use the M2.5 Allen Wrench to remove two turbofan bolts.

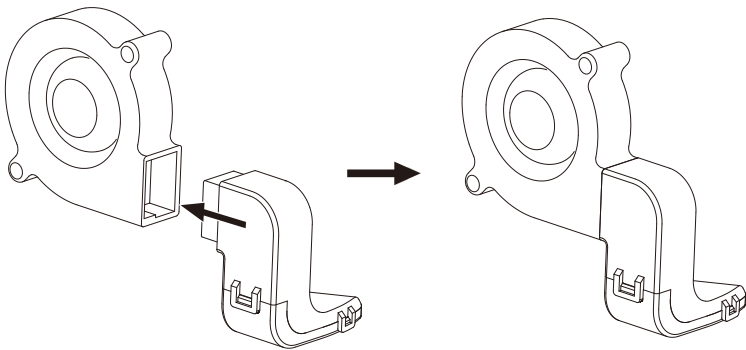

2. Take the turbofan baffle from the extruder's accessory kit.
3. Install the turbofan baffle to the turbofan.

Turbofan Seat

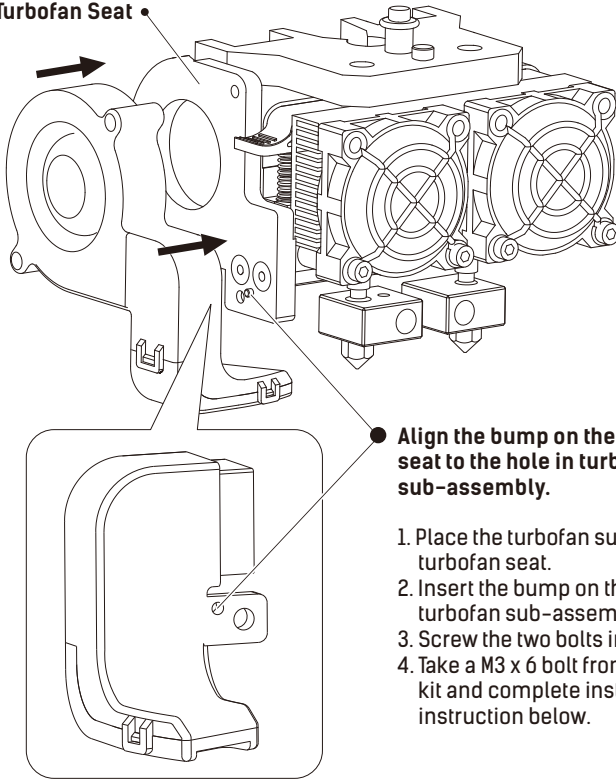

1. Place the turbofan sub-assembly besides the turbofan seat.
2. Insert the bump on the turbofan seat to the turbofan sub-assembly.
3. Screw the two bolts in.
4. Take a M3 x 6 bolt from the extruder's accessory kit and complete installation according to the instruction below.

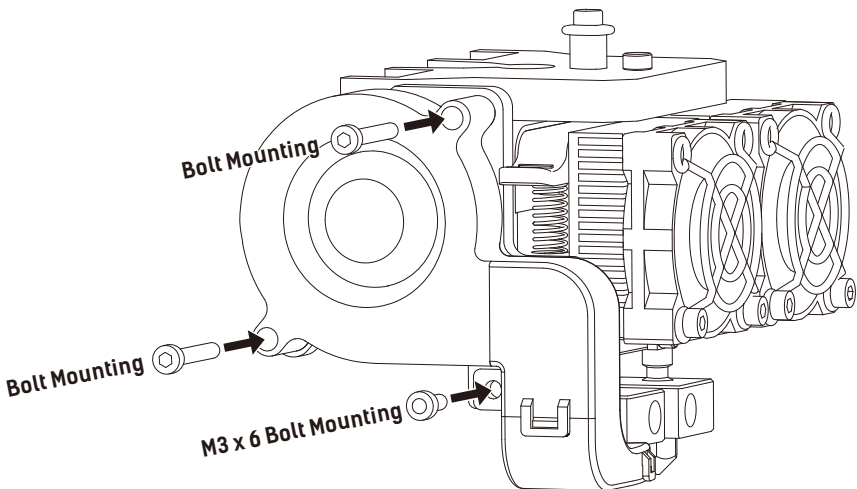

1. To install a spool holder, level it and insert the end into the corresponding opening.

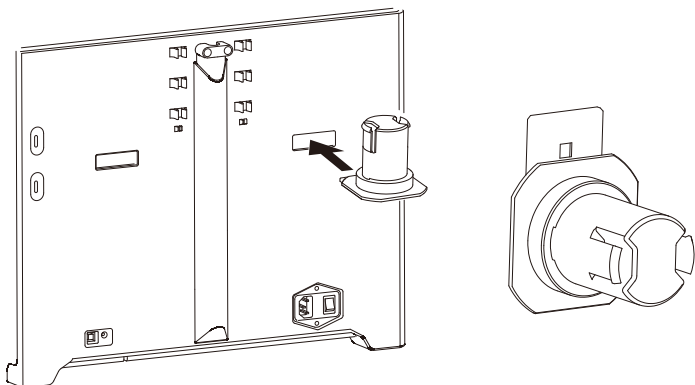

2. Turn down the spool holder to make the holder bottom cleave to the printer back.

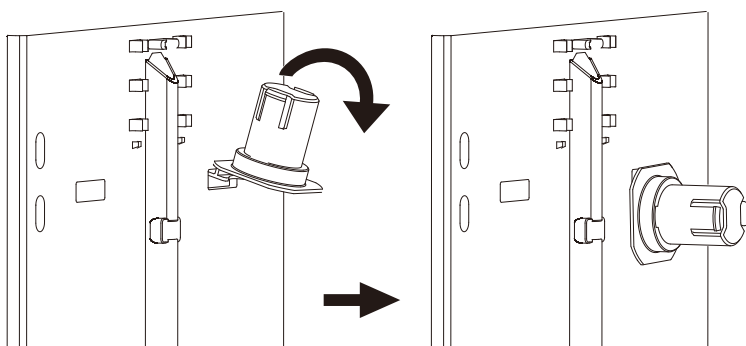

3. Take a roll of filament, then squeeze the spool holder top and mount the filament spool to the holder.

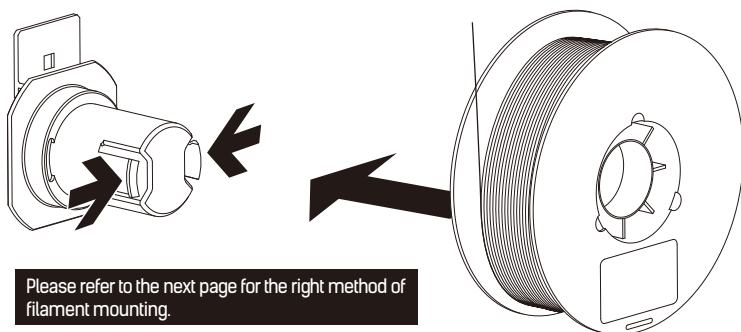

Please refer to the next page for the right method of filament mounting.

Tips

- The filament spool must be oriented correctly (see below).
- The filament guide tube ensures stable printing and protects the printer.
- After securing the filament and guide tubes, thread the filament through the guide tubes.

Filament Guide
Tube Buckle

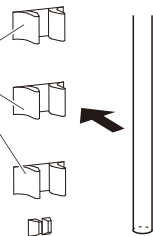

4. Lock the filament guide tube with R-shape buckles.

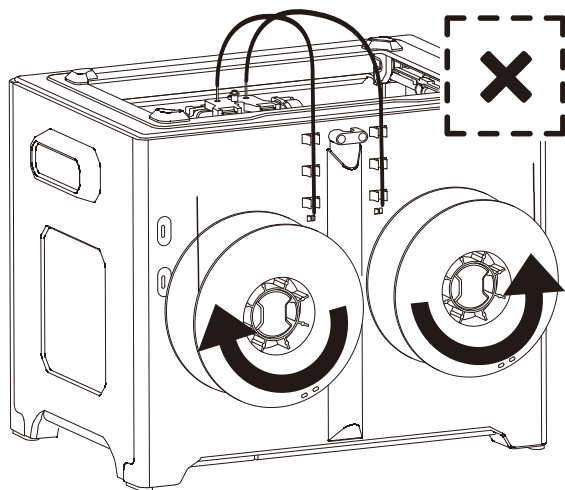
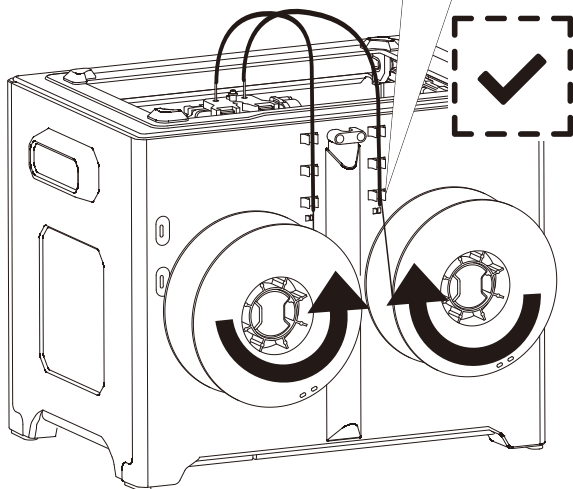

Chapter 5: Build Plate Leveling

Every printer will be leveled before shipped out, but we can't ensure that the platform won't move during delivery, so it will be better to level platform before you begin to print.

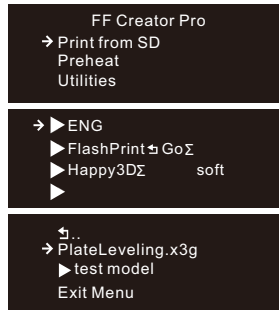
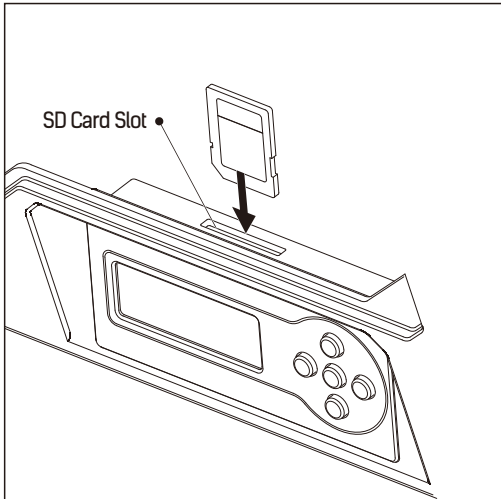

1. Attach the power supply, plug the power cable into an electrical outlet and turn on the printer.
2. Insert the SD card into the slot. Tap [Print from SD] and Tap [OK]. Tap [ENG] and tap [OK].

Then you will see the [Plateleveling.x3g].

How to use the leveling knobs

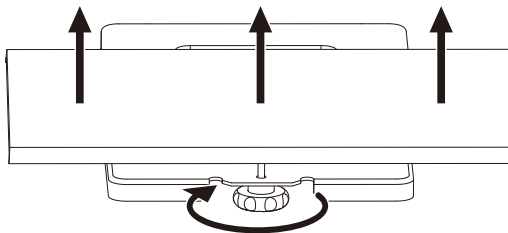

Rotate knob clockwise

Raise the build plate to reduce the distance between the nozzle and build plate.

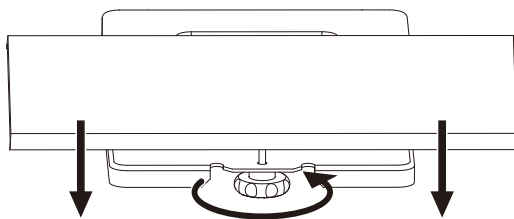

Rotate knob anticlockwise

Lower the build plate to increase the distance between the nozzle and build plate.

How to level the build plate

1. Tighten the three leveling knobs under the build platform until you cannot tighten them any more.
2. Select the [PlateLeveling.x3g] on the control panel, and tap [OK] to start leveling. Then tap [OK] for page-turning to read the leveling instructions.
3. The build plate and nozzle will start to move. Wait for them to stop, then adjust the corresponding knob under the right nozzle first using the leveling card.
4. The leveling card should slide between the nozzle and build plate with some friction/resistance. If the card slides through easily, the nozzle and build plate are too far apart. Rotate the knob clockwise to decrease the distance between them. If the card cannot slide through, rotate the knob anticlockwise.
5. After leveling the first point, tap [OK] to continue to the next point.
6. Adjust all three knobs as outlined above. Then, check that the nozzle is also correctly placed when it is at the center of the build plate, using the leveling card. That's it!

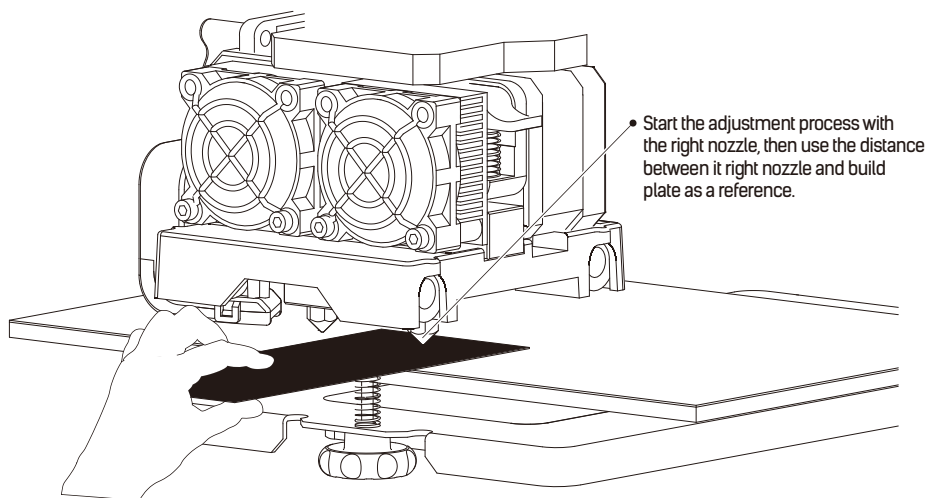

Chapter 6: About Software

This chapter talks about the basic function of FlashPrint. For more information about advanced function, you can browse our website www.flashforge.com.

6.1 Software Installation

6.1.1 Software Acquisition

- ◆ **Method 1:** To get the installation package from the SD card in the accessory kit.
- ◆ **Method 2:** Open the link below to download the installation package: www.flashforge.com

Steps: Support - Downloads - FlashPrint - Choose Software Version - Download

6.1.2 Software Installation and Start-up

1. Decompress the zipped file or start the installation program, and then install the software according to the direction.
2. Start the software with the start menu shortcut or by clicking the software icon.

6.2 Exploring FlashPrint

Note: Before updating Firmware, you need to install a relevant drive.

6.2.1 Machine Type Selection

Attention! After starting FlashPrint, you need to select the target machine type first.

When you start FlashPrint, a dialog box will pop up. Just need to select FlashForge Creator Pro in the machine type list and click [OK].

You can also change the machine type via clicking [Print] - [Machine type].

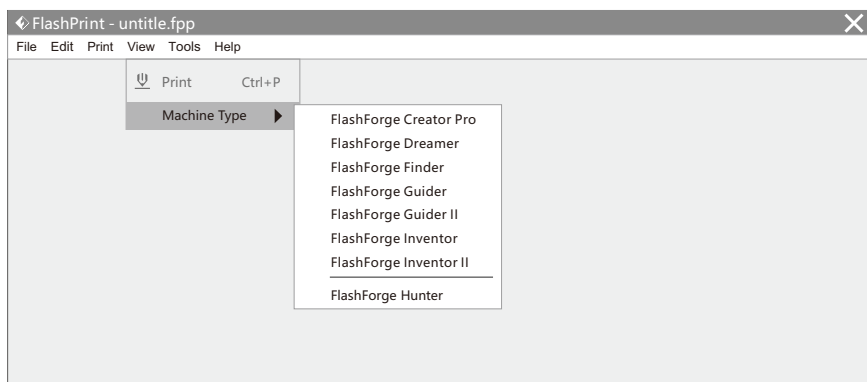

6.2.2 Software Introduction

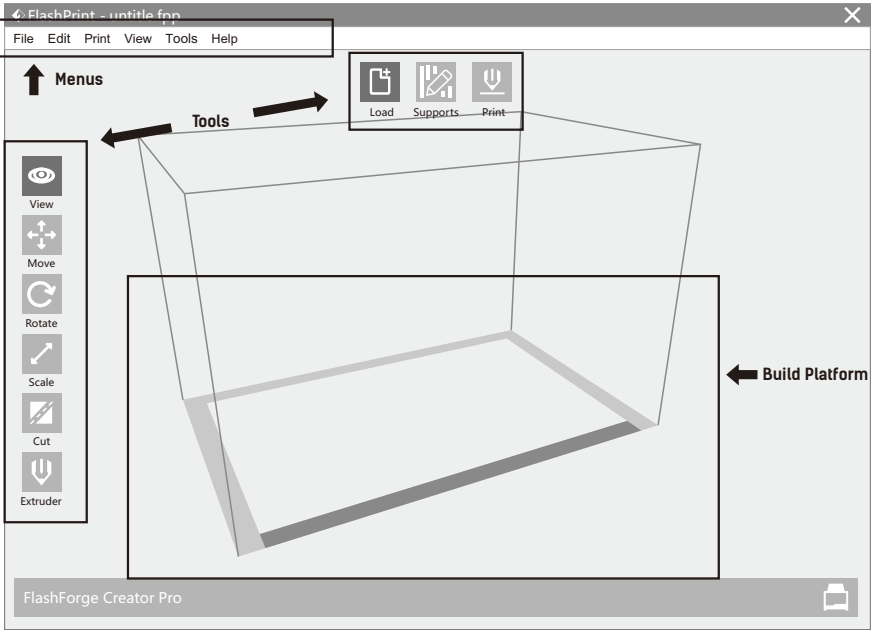

Load
Load files



Supports
Enter into the support edit mode



Print
Print it directly with your Creator Pro or export to your USB Stick



View
View FlashPrint home screen from one of six viewing angles



Move
Move model around on XY- axis; shift+click to move along Z axis



Rotate
Turn and rotate your model



Scale
Scale the size of your object



Cut
Cut model into several parts



Extruder
Select right or left extruder you want to print with

6.2.3 Loading



You can load a model file or Gcode file into your FlashPrint by the following six methods:

- ◆ Method 1: Click the Load icon on the main interface. Then select the object file.
- ◆ Method 2: Select the file for loading and drag the file to the main interface of the software.
- ◆ Method 3: Click [File] - [Load File]. Then select the object file for loading.
- ◆ Method 4: Click [File] - [Examples] to load the example files.
- ◆ Method 5: Click [File] - [Recent Files] to load the files opened recently.
- ◆ Method 6: Select and click-drag the target file to the icon of FlashPrint.

Note: .STL, .OBJ, and .FPP, ways to store 3D models, are supported by FlashPrint for editing.

Generating Rilievo

Load a png, jpg, jpeg, bmp picture file into the FlashPrint. And the following dialogue box will pop up. The setting box includes settings for shape, mode, maximum thickness, base thickness, bottom thickness, width, height, top diameter and bottom diameter.

Shape: including plane, tube, canister and lamp.

Mode: including "darker is higher" and "lighter is higher".

Maximum thickness: Z value of the model.

Base thickness: The minimum raft thickness and the default value is 0.5mm.

Width: X value of the model.

Depth: Y value of the model.

Bottom thickness: For tube, canister and lamp to set up bottom thickness.

Top diameter: For tube, canister and lamp to set up the top diameter.

Bottom diameter: For tube, canister and lamp to set up the bottom diameter.

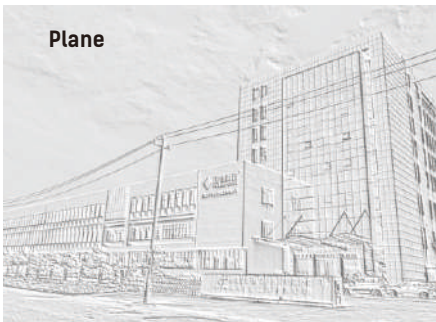
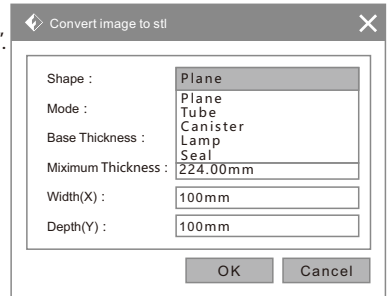

Tube / Canister



Lamp



Seal

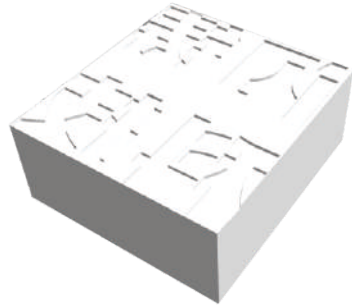

6.2.4 Views



1. Changing Views

Change model views by moving, rotating, scaling.

Drag:

Click the [View] icon and then you can move the object by the following three methods:

- ◆ Method 1: Hold down the left mouse button and drag.
- ◆ Method 2: Hold down the mouse wheel and scroll up and down.
- ◆ Method 3: Hold down the Shift key, hold down the right mouse button and drag.

Rotate:

Click the [View] icon and then you can rotate the object by the following two methods:

- ◆ Method 1. Hold down the right mouse button and drag.
- ◆ Method 2. Hold down the Shift key, hold down the left mouse button and drag.

Scale:

Scroll the mouse wheel to enlarge or shrink the build plate.

2. Set View

Allow users to view the object on the build plate. Six views are under the view menu, that is bottom view, top view, front view, back view, left view and right view.

Method 1: Click the the [View] button, there are six views in the drop- down list.

Method 2: Click the the [View] icon on the left, click it again and a submenu will appear with six views for selecting.

3. Reset View

Allow users to reset views by the following two methods:

Method 1: Click the [View] menu and select [Home View].

Method 2: Click the [View] button on the left, click it again and you will see the viewing options, you can click [Reset].

4. Show Model Outline

Click [View] - [Show Model Outline], it will highlight the yellow border of the object.

5. Show Steep Overhang

Click [View] – [Show Steep Overhang]. When the intersection angle between the model surface and horizontal line is within the overhang threshold value, the surface has steep overhang and it becomes red in the software. Overhang threshold value could be set as needed. The default value is 45 degree.

6.2.5 Move

Select the object and move the object by the following two methods:

- ◆ Method 1: Click the [Move] icon on the left, hold down the left mouse button and drag it to adjust the location of the model in XY direction. Hold down the Shift key, hold down the left mouse button and drag it to adjust the location of the model in Z direction. The distance and the direction of the movement will be displayed.
- ◆ Method 2: Click the [Move] button on the left and then enter the distance value to move the model. You can also click [Reset] to reset distance values.

Note: Users shall click [Center] and [On Platform] after the location adjustment to ensure the model(s) be within the build area and on the build platform. If a specified position is needed, only click [On Platform].

6.2.6 Rotate

Select the target object and rotate the object by the following two methods:

- ◆ Method 1: Click the [Rotate] icon on the left and three mutually perpendicular rings appear around the object. Click one ring and rotate on the present axis, you will see the rotation angle and direction in the center of circle. In this way, you could make the model rotate on X/Y/Z axis.
- ◆ Method 2: Click the [Rotate] icon on the left, and then enter into rotating angel values in X/Y/Z axes positioning. Click [Reset] to reset rotating angel values.

6.2.7 Scale

Select the target object and scale the object by the following two methods:

- ◆ Method 1: Click the [Scale] icon on the left, hold down the left mouse button and scale the model. The corresponding values will display near the object.
- ◆ Method 2: Click the [Scale] icon on the left and then enter into scale values in X/Y/Z axes positioning. Click the [Maximum] button to get largest size possible for building. Click [Reset] to reset the size of model.

Note: If the [Uniform Scaling] radio button is clicked, it will scale the model in equal proportion when changing value in any positioning of the model. Otherwise it will only change the value of the corresponding positioning.

6.2.8 Cut

Click on the model to select it and click on the Cut icon to set the cut plane. The direction and position are available for setting.

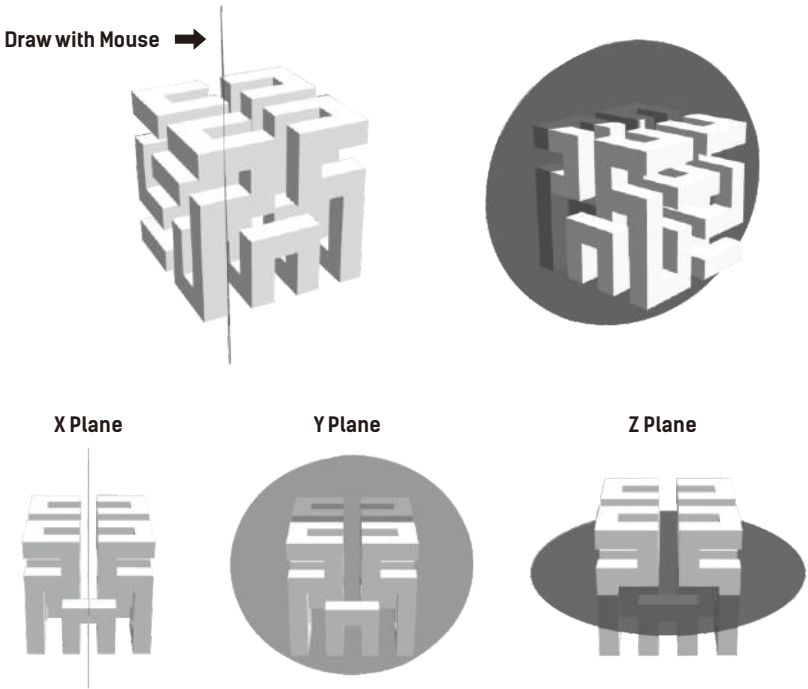

6.2.9 Keep Parts in Place

Click the model to select it, then double-click the Cut icon in the left to choose L/R extruder.

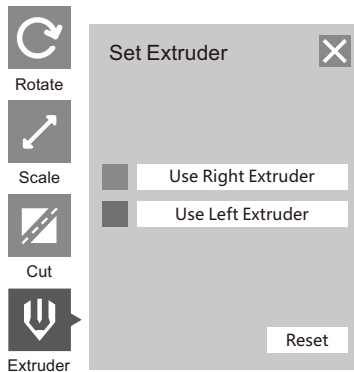

6.2.10 Supports

After loading the model, click [Edit]--[Supports] or click the Supports icon directly, then you will enter the support edit mode (as shown in the picture below). Click [Back] to exit when you finish editing.

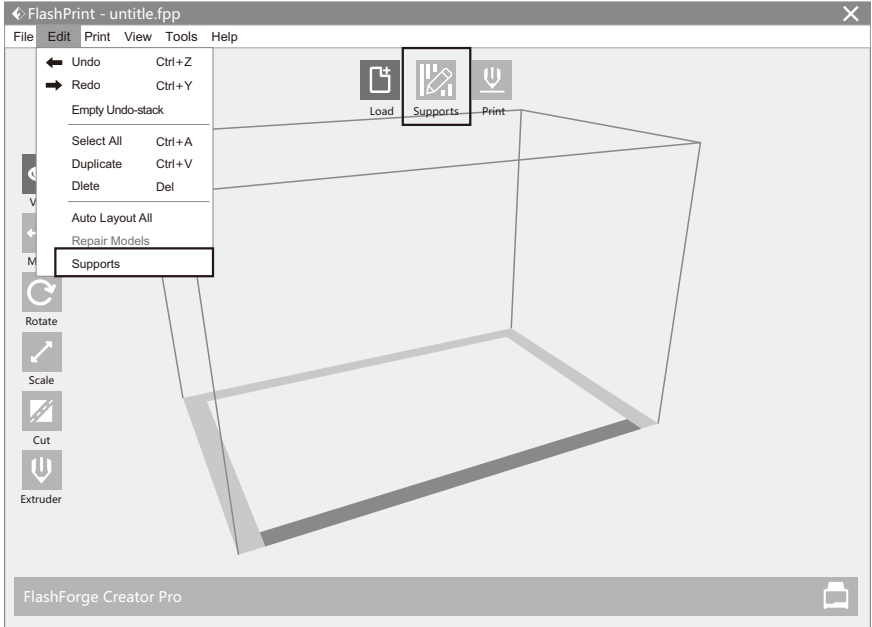

1. Support Options

Click the Support Options, an option box will appear, supports options include "treelike" and "linear", when choose "treelike", click [OK], then it will generate treelike structure; when choose "linear", click [OK], then it will generate linear structure.

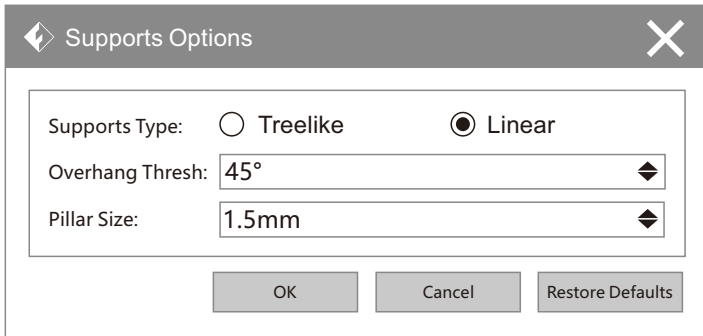

Supports Options
✕

Supports Type: Treelike Linear

Overhang Thresh: ▾

Post Diameter: ▾

Base Diameter: ▾

Base Height: ▾

OK

Cancel

Restore Defaults

Treelike

2. Auto Supports A

Click the [Auto Supports] button, the software will judge the position where supports are needed and generate corresponding treelike or linear supports. If it is a model with supports, the existing supports will be deleted and new supports will be generated.

3. Add Supports +

Supports will be added once clicking the [Add] button. Move the cursor to the position where supports needed, left-click to choose the starting point of supports, hold down the left mouse button and drag the mouse the supports preview will show up(if support surface doesn't need support or the support column angle is too large, the support review will be highlighted). Loosen the left mouse button, if support column doesn't meet with model, then support will be generated on origin and terminal point(the highlighted preview support won't generate support structure)

3. Clear Supports 🗑️

Click [Clear Supports], all supports will be deleted. The operation can be repealed via clicking [Undo] or pressing the shortcut key Ctrl+Z.

4. Delete Supports ✕

Supports will be deleted once clicking the [Delete] button. Move the cursor to the supports needed deleting, current supports and its subnode support will be highlighted, click the left mouse button to delete these highlighted support.

6.2.11 Print

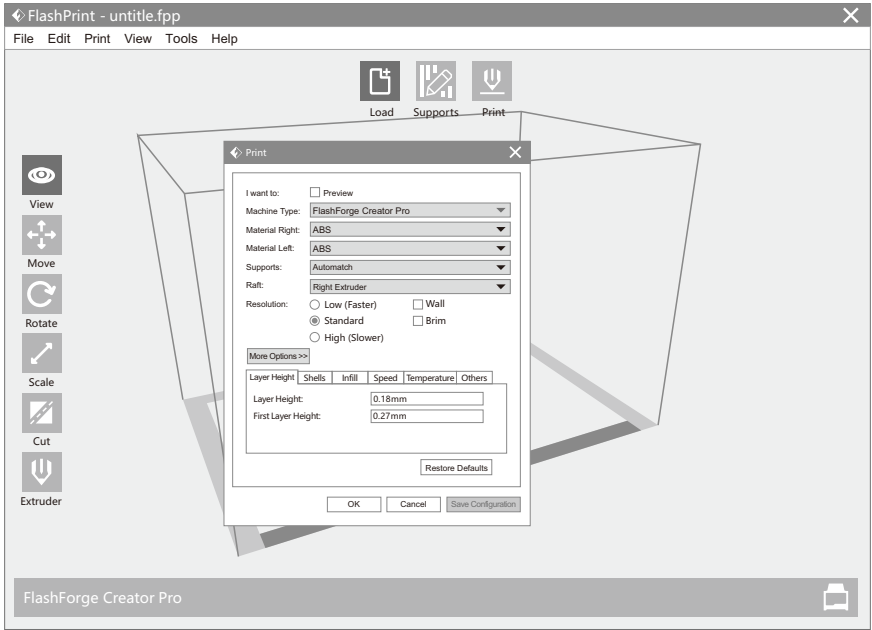

- 1. Preview:** Choose to enter preview interface or not.
- 2. Machine Type:**
- 3. Material Right/Left:** Choose a type of material according to the type of model.
- 4. Supports:** When print suspended structure models, support is necessary. Click [Supports] to create support part for the printing.
- 5. Raft:** This function will help the model to stick well on the platform.
- 6. Wall:** During dual color printing, this function will help to clear the leaking filament of another extruder.
- 7. Brim:** Expand the outline of model's bottom layers to a brim which helps anchor the edges of model to the plate to avoid warping.
- 8. Resolution:** You have three resolution solution (with default setting) to choose from, high resolution is corresponding with slow printing speed, opposite for the low resolution. For PLA printing, an extra solution "Hyper" is available.
- 9. More options:** Click [More options] to set for layer, shell, infill, speed and temperature. Different resolution solution is corresponding to different defaults, click [Restore Defaults] to back to default setting.

Layer Height

Layer Height: Layer thickness of the printing model. With a small value, the surface of the model will be smoother.

First Layer Height: This is the first layer of the model, which will affect the sticking performance between the model and platform. Maximum is 0.4mm, and usually the default is OK.

Shells	<p>Contains the outside shell value, capping layer value (under vase mode, top solid layer setting is invalid.)</p> <p>Perimeter Shells: Maximum is 10</p> <p>Top Solid Layers: Maximum is 30, minimum is 1.</p> <p>Bottom Solid Layers: Maximum is 30, minimum is 1.</p>
Infill	<p>Fill Density: Fill rate.</p> <p>Fill Pattern: The pattern of filling shape which effects printing duration.</p> <p>Combine Infill: You can select the layers for combining according to the layer thickness. The combined thickness should not exceed 0.4mm. "Every N layers" is for all the infills while "Every N inner layers" is only for inner infills, which generally can save print time.</p>
Speed	<p>Print Speed: The moving speed of the extruder. Generally, the lower speed is, the better print you will get. For PLA printing, 80 is recommended.</p> <p>Travel Speed: Control the moving speed of the extruder under non-printing Status during work. For PLA printing, 100 is recommended.</p>
Temperature	<p>Extruder Temperature: Recommended extruder temperature is 220°C. Note: Different temperatures have subtle influences in prints. Please adjust the temperature according to the condition in order to get a good print.</p> <p>Platform Temperature: To set the temperature of Platform.</p>
Others	<p>Cooling Fan Control: Set up the time to turn on the cooling fan. You can pre-set the height and make the cooling fan begin to work at the point.</p>

6.2.12 File Menus

1. **New Project:** Click [File]--[New Project] can build a blank project. If there is an unsaved modification on previous project, then it will inform you whether the modification needs to be saved or not. Click [Yes] will save the modification, and then click [No] will abandon it. If click [Cancel] or close tool tip, then it will cancel the new project.
2. **Saving:** After finishing the model edit and adjustment, there are two ways below to save all models in the scene.
 - ◆ Method 1: Click [File]--[Save Project] in the menu bar to save the file as a project file with the ".fpp" suffix, all models in the scene (include support) are independent. If reloading the files, extruder configuration information and model position will be the same as the configuration during saving.

- ◆ Method 2: Click on [File]--[Save As...] to save the model as project file .fpp or .stl and .obj. For .stl and .obj, models are integrated as one (include support part). If load it again, only the position of the model was saved, not included the printing parameters.

3. Preferences: Click [File]--[Preferences], you can choose language and if needs detecting update when start

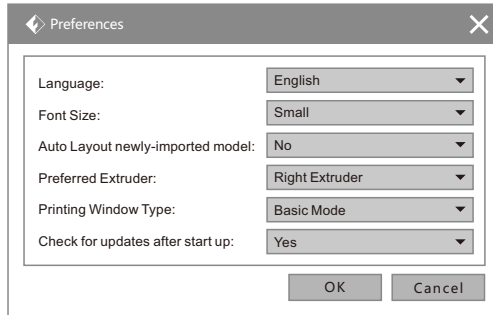

- ◆ **Language:** The software supports several languages, namely, Chinese (simplified Chinese and traditional Chinese), English, French, Korean, Japanese and so on.
- ◆ **Font Size:** Set the front size.
- ◆ **Auto layout newly-imported model:** Set YES or NO.
- ◆ **Preferred Extruder:** Set preferred extruder to print with.
- ◆ **Printing Window Type:** Including base model and expert model.
- ◆ **Check for Update after start up:** It is used to preset if it is necessary to activate the online automatic update function, if choose yes, every time when you open software, it can online detect if it is the latest version, once a new version found, it will reminds users to download and install the new version.

6.2.13 Edit Menus

1. Undo: Allows users to undo the recent edits by the following two methods:

- ◆ Method 1: Click [Edit]--[Undo].
- ◆ Method 2: Press the shortcut key Ctrl+Z.

2. Redo: Allows users to redo the most recent edit you have undone to your model file by the following two methods:

- ◆ Method 1: Click [Edit]--[Redo]
- ◆ Method 2: Press the shortcut key Ctrl+Y.

3. Empty Undo-stack: To clean up the recorded operating steps so as to release the memory.

4. Select All: By the following two methods, you could select all models in the scene. (When models are too small to be seen or out of viewing scope, please click [Center] and [Scale] buttons to adjust the model.)

- ◆ Method 1: Click [Edit]--[Select All].
- ◆ Method 2: Press the shortcut Ctrl+A.

5. Duplicate: Select the object and duplicate the object through the following two methods:

- ◆ Method 1: Click [Edit] – [Duplicate].
- ◆ Method 2: Press the shortcut key Ctrl+V.

6. Delete: Select the object and delete the object through the following two methods:

- ◆ Method 1: Click [Edit] – [Delete].
- ◆ Method 2: Press the shortcut key Delete.

7. Auto Layout All: Click [Edit] – [Auto Layout All] after loading one or more than one models, all models will be placed automatically as automatic placement rule.

8. Repair Models: Recover model error.

9. Supports: Refer to Chapter 6.2.10.

6.2.14 Tools

6.2.14.1 Update Firmware

Before updating firmware, you need to find and depress “driver-creator-pro” in the SD card. Click and install the relevant installation program.

Launch the FlashPrint (Now your computer and Creator Pro are connecting with each other), click [Tools] and [Update Firmware], then click [OK] and a dialog box will pop up. Click [Yes] to start firmware update.

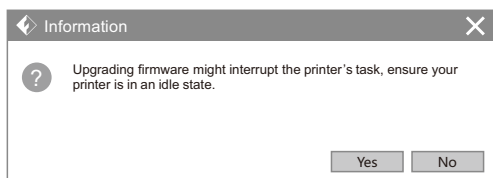
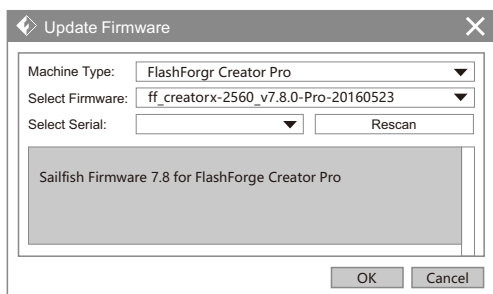

6.2.15 Help Menus

1. First Run Wizard

2. Help Contents: Click [Help]--[Help Contents], you can read flashprint user guide.

3. Check for Updates: Click [Help]--[Check for Update] to detect the available updates online.

4. About FlashPrint: Click [Help]--[About FlashPrint], the software information box will pop up. The contents include the current software version and copyright information.

Chapter 7: Basic Printing

This chapter will provide a step-by-step guide on turning a 3D model into a physical reality. Before proceeding, it is recommended that you go over prior chapters on loading/unloading filament, leveling the build platform, and the functions and capabilities of FlashPrint.

7.1 Generate a Gcode

Double-click the icon of FlashPrint to start the software.

Click [Print]--[Machine Type] to select FlashForge Creator Pro.

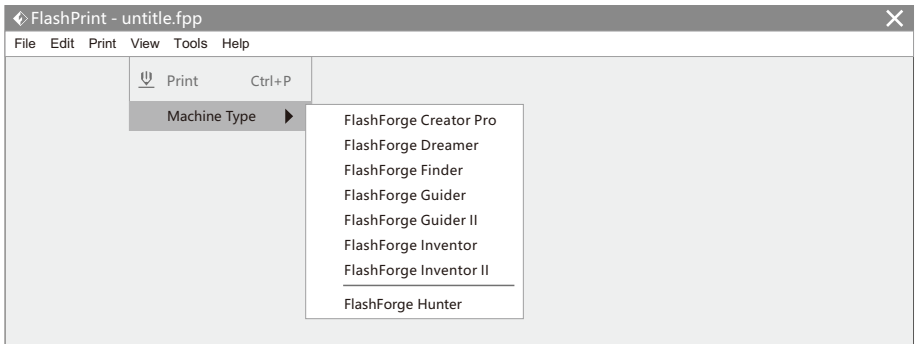

Click the [Load] icon to load a .stl model file and the object will be displayed on the build area.

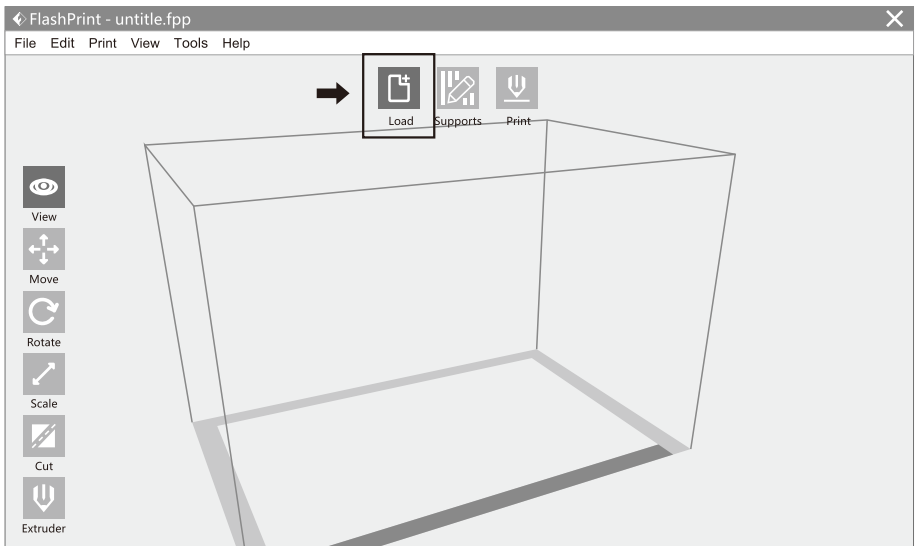

Click the model to select it, then click the icon in the left [Rotate] – [Surface to Platform] to make your model perfectly positioned on the build area. Click [Back] and double-click the Move icon again, then click [On the Platform] and [Center] to ensure the model be placed on the platform.

Note: If you've placed your model in a right place, you can skip the step above.

Click the Print icon on the top, and you should make some setups for your print job.

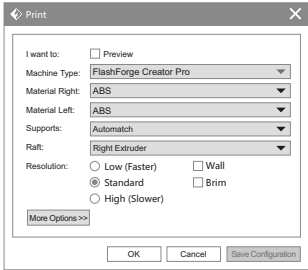

Preview: If you check the [Preview] box, you can preview your model after slicing is done.

Machine Type: FlashForge Creator Pro

Supports: If you print a model with supports, you should click the inverted triangle and select [Enable].

Raft: You are suggested to select [Enable].

Resolution: You are suggested to select [Standard].

More Options: You are suggested to keep them default.

Click [OK] to select the path to save the Gcode file. You can rename the file as you like and save it as a x3g file, click [Save] to generate a Gcode file.

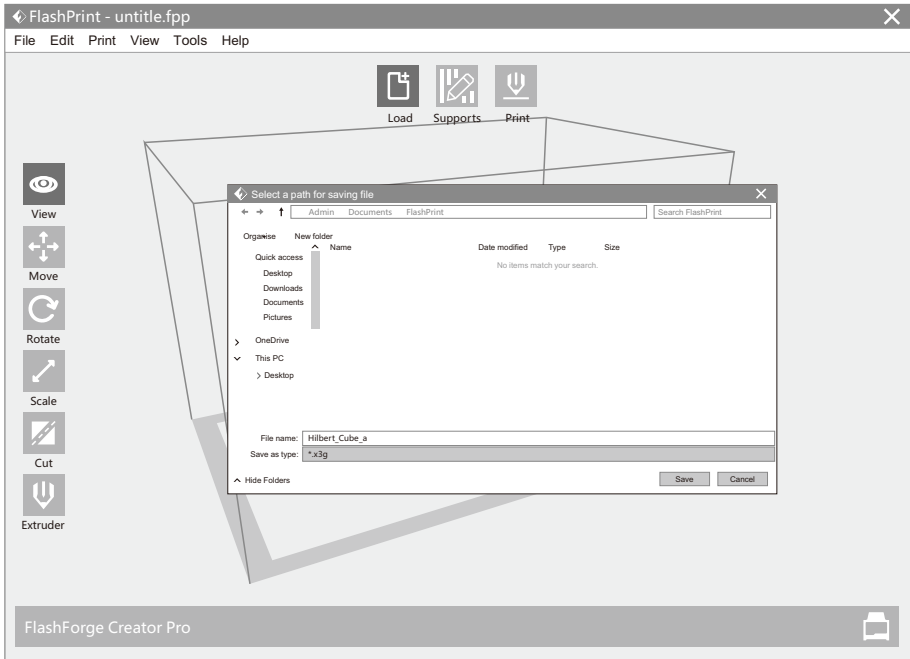

Next, we are going to print the model.

Next, we are going to print the model. Before printing, users should:

1. properly install the dual extruder.
2. properly install the filament guide tube.
3. properly mount the filament spool and feed the filament.

To make the process of feeding or withdrawing the filament easy, please follow the next few steps carefully: After inserting the filament into the filament intake, do not push it further until the extruder temperature reaches 200°C or higher. Once the machine reaches this point, you will feel the filament being pulled into the extruder head.

7.2 Loading Filament

Turn on the Creator Pro; using the directional arrow buttons in the right of the screen, to select Utilities and then press the [OK].

FF Creator Pro
Print from SD
Preheat
→ Utilities

Select Filament loading, press the [OK] key of the keypad.

Monitor Mode
→ Filament loading
Preheat Setting
General Settings

→ Unload Right
Load Right
Unload Left
Load Left

Select the appropriate side of the extruder you wish to load (Left or Right for models with dual extruders). Press the [OK] key again on the keypad. The display will indicate: "I'm heating up my extruder!" At this time, the temperature of the right nozzle is being heated up. When the temperature of the nozzle reaches its target temperature, pressing the [OK] key on the keypad, and the nozzle should start extruding filament. If not, keep pressing the [OK] key until it does.

7.3 Unloading the Filament Using LCD Panel

! CAUTION

If you want to withdraw the filament after just finishing your printing or extruding, first press down the spring presser and push the filament in a little further, and then directly pull it out when the extruder temperature is still over 200°C.

If you want to change another color filament, first you need to withdraw filament and then load in. Please do as following shown to avoid filament jam.

Turn on the Creator Pro. Using the directional arrow buttons in the right of the screen, to select Utilities and then press the [OK].

FF Creator Pro
Print from SD
→ Preheat
Utilities

→ Start Preheating
Right Extruder OFF
Left Extruder OFF
Platform OFF

Press page down key to select Left Extruder (or Right Extruder), press [OK] key, you will see:

```
Start Preheating
→ Right Extruder      ON
  Left Extruder       OFF
  Platform             OFF
```

Press page up key back to Start Preheat, and Press [OK] key, you will see:

```
Heating :
R Extruder : 33/230°C
L Extruder : 33/230°C
Platform : 024°C
```

This means the left extruder is heating up, when it reaches 220°C. First push in the filament a little bit until you see filament come out of the nozzle, press the spring presser then pull it out quickly. This will ensure you have withdrawn the filament inside the nozzle successfully.

Then users should:

1. Insert your SD card with target x3g file to your Creator Pro. .
2. Turn on the Creator Pro.
3. Select [Print from SD] on the LCD panel.
4. Select the file you want to print and press [OK].
5. And the printer will heat up the nozzle and the build plate automatically and start to print after the nozzle and the build plate reaches the aimed temperature.

Chapter 8: Function

In this chapter, we will introduce the Creator Pro function to you. We will mainly introduce Utilities function and other available functions in printing process, as Print from SD and Preheat are introduced in prior chapters.

Utilities

Using the directional arrow buttons in the right of the screen to select Utilities, Press OK key on the keypad, then you will see:

1. Monitor Mode

Select it and then press OK, the display will indicate:

Creator Pro
R Extruder
L Extruder
Platform

2. Filament loading: Refer to Chapter 7

3. Preheat Setting: Refer to Chapter 7

4. General Settings

Select it and then press OK, the display will indicate:

Ditto Printing	(The dual-extruder print one model simultaneously)
Override Gcode	(Reselect)
Pause with Heat	(Whether continue heating when pause printing)
Sound	
Acceleration	
Extruder Count	

5. Level Build Plate

Build plate leveling refers to Chapter 5.

6. Home Axes

Select it and then press OK. The dual-extruder will move backwards, and the build plate will elevate up. It means Creator Pro is ready for printing.

7. Bot Statistics

Select it and then press OK, the display will indicate:

Lifetime	(Accumulated time for printing)
Last Print	(Spent time for the last printing)
Filament	(Accumulated filament length for printing)
Fil. Trip	(Accumulated filament length for printing)

8. Filament Odometer

Select it and then press OK, the display will indicate:

Life	(Accumulated filament length for printing)
Trip	(Accumulated filament length for printing)
Reset	(Press OK to reset the Trip data)

9. Profiles

Select it and then press OK, the display will indicate:

ABS
PLA
Profile1
Profile2

Select any option and press OK; the display will indicate:

Restore (Back to Utilities)
Display Config
Change Name
Save To Profile

Select Display Config and then press OK ; the display will indicate

Config
X Offset
Y Offset
Z Offset
Right Temp
Left Temp
Platform Temp
Change Name
Save To Profile

10.Home offsets

Select it and then press OK, the display will indicate:

X Offset
Up/Dn/Left/OK to Set (Press Up button and Down button to change the X/Y axis coordinate;
press OK to confirm; press Left button to back.)

11. Toolhead Offsets

12. Jog Mode

Select it and then press OK, the display will indicate:

X+		Press Right/Left button change the X/Y/Z axis interface;
(Menu)	Y- >	press Up/Dn button to change the coordinate;
X-		press OK button to back.

13. Enable steppers

Select it and then press OK, the display will indicate:

Disable Steppers

Steppers is lock. It means the position of extruder or build plate cannot be manually adjusted.
Press OK button again to back to Enable steppers. It means the position of extruder or build plate can be manually adjusted.

14. Auto-Level Adj

15. Auto-Level Variance

16. Max Z Probe Hits

Select it and then press OK, the display will indicate the distance build plate descending after printing job completed.

17. Calibrate Nozzles

Select it and then press OK, the display will indicate:

X Axis Line
Y Axis Line
Done

18. Restore Settings

Select it and then press OK, the display will indicate:

Restore factory settings ?
NO
YES

19. Eeprom

The setting is not suggested modified by users. Improper operation may cause the device shutting down.

20. Version Information

Select it and then press OK, the display will indicate the basic information of the printer.

21. Exit Menu

Options during printing process: In the process of printing, we may encounter the inevitable problem. At that situation, we have to pause printing.

First, press OK button or Left button to back to the menus. Then you will see:

1. Back to Monitor

Select it and then press OK, the display will indicate:

Printer name
Printing progress
R Extruder
L Extruder
Platform

2. Cancel Print

3. Pause

4. Pause at ZPos

5. Change Speed

6. Change Temperature

7. Change HBP Temp

8. Set Cooling Fan

When it display ON, press OK button. Then it will display OFF. It means the cooling fan starting working;
When it display OFF, press OK button. Then it will display ON. It means the cooling fan stopping working.

9. Set Lights Off

10. Print Statistics

Select it and then press OK, the display will indicate:

Print Time	(Spent time for printing)
Time Left	
Filament	(Accumulated filament length for printing)
Auto-level inactive	(build plate cannot move)

11. Cold Pause

After selecting it and pressing OK, the extruder and build plate will move to the initial position. It may cost several seconds. And then the display will indicate:

1. Back to Monitor

2. Cancel Print

3. Unpause

After selecting it and pressing OK, the extruder begins heating up. The printer will resume printing when the extruder reaches the target temperature.

4. Jog Mode

5. Filament Loading

6. Change Speed

7. Change Temperature

8. Change HBP Temp

9. Set lights OFF

10. Print Statistics

Chapter 9: Supports and Service

FlashForge team is on standby and ready to help you with any problems you may have with your Creator Pro. If the issues or questions are not covered in this User Guide, you can seek for solutions on our official website or contact us via telephone.

There are solutions and instructions to common issues that can be found in our knowledge base. Have a look first as most basic questions are answered there. www.flashforge.com

The FlashForge support team can be reached by e-mail or phone between the hours of 8:00 a.m. to 5:00 p.m. PST Monday through Saturday. In case you contact us during off-duty time, your inquiry will be answered the following business day.

Note: Because of change different filament the extruder maybe blockaded. It's not owing to quality issue, and outside the scope of 400 hours life. If users encounter this problem, please contact our after-sales department and finish clean work according to their instruction.

Tel: 400-699-1063

QQ: 2850862986 2850863000 2853382161

ADD: No. 518, Xianyuan Road, Jinhua, Zhejiang, China.

*** When contacting support, please have your serial number ready. The serial number is a bar code on the back of your Creator Pro. ***

