

Test Equipment Depot - 800.517.8431 - 99 Washington Street Melrose, MA 02176 - TestEquipmentDepot.com

Model 77 Series IV

Digital Multimeter

Users Manual

PN 2695884

September 2006 Rev.1, 11/15

© 2006-2015 Fluke Corporation. All rights reserved.

All product names are trademarks of their respective companies.

Lifetime Limited Warranty

Each Fluke 20, 70, 80, 170 and 180 Series DMM will be free from defects in material and workmanship for its lifetime. As used herein, "lifetime" is defined as seven years after Fluke discontinues manufacturing the product, but the warranty period shall be at least ten years from the date of purchase. This warranty does not cover fuses, disposable batteries, damage from neglect, misuse, contamination, alteration, accident or abnormal conditions of operation or handling, including failures caused by use outside of the product's specifications, or normal wear and tear of mechanical components. This warranty covers the original purchaser only and is not transferable.

For ten years from the date of purchase, this warranty also covers the LCD. Thereafter, for the lifetime of the DMM, Fluke will replace the LCD for a fee based on then current component acquisition costs.

To establish original ownership and prove date of purchase, please complete and return the registration card accompanying the product, or register your product. Fluke will, at its option, repair at no charge, replace or refund the purchase price of a defective product purchased through a Fluke authorized sales outlet and at the applicable international price. Fluke reserves the right to charge for importation costs of repair/replacement parts if the product purchased in one country is sent for repair elsewhere.

If the product is defective, contact your nearest Fluke authorized service center to obtain return authorization information, then send the product to that service center, with a description of the difficulty, postage and insurance prepaid (FOB Destination). Fluke assumes no risk for damage in transit. Fluke will pay return transportation for product repaired or replaced in-warranty. Before making any non-warranty repair, Fluke will estimate cost and obtain authorization, then invoice you for repair and return transportation.

THIS WARRANTY IS YOUR ONLY REMEDY. NO OTHER WARRANTIES, SUCH AS FITNESS FOR A PARTICULAR PURPOSE, ARE EXPRESSED OR IMPLIED. FLUKE SHALL NOT BE LIABLE FOR ANY SPECIAL, INDIRECT, INCIDENTAL OR CONSEQUENTIAL DAMAGES OR LOSSES, INCLUDING LOSS OF DATA, ARISING FROM ANY CAUSE OR THEORY. AUTHORIZED RESELLERS ARE NOT AUTHORIZED TO EXTEND ANY DIFFERENT WARRANTY ON FLUKE'S BEHALF. Since some states do not allow the exclusion or limitation of an implied warranty or of incidental or consequential damages, this limitation of liability may not apply to you. If any provision of this warranty is held invalid or unenforceable by a court or other decision-maker of competent jurisdiction, such holding will not affect the validity or enforceability of any other provision.

Table of Contents

Title	Page
How to Contact Fluke	1
Safety Information.....	1
Symbols	2
Unsafe Voltage	3
Test Lead Alert	3
Battery Saver (Sleep Mode)	4
Terminals	4
Rotary Switch Positions.....	4
Display	5
MIN MAX AVG Recording Mode	6
AutoHOLD Modes.....	6
YELLOW Button	6
Display Backlight	6
Manual Ranging and Autoranging	7
Power-Up Options	7
Making Basic Measurements	8
Measuring AC and DC Voltage	8
Measuring Resistance	8
Measuring Capacitance	8
Testing for Continuity.....	9
Testing Diodes.....	9
Measuring AC or DC Current	10
Measuring Frequency.....	10
Using the Bar Graph	11
Cleaning.....	11
Testing the Fuses	11
Replacing the Battery and Fuses	12
General Specifications.....	13

Model 77 Series IV

Digital Multimeter

The Fluke **Model 77 Series IV** is a battery-powered, average responding-rms indicating multimeter (hereafter "the Meter"), with a 6000-count, 3 3/4-digit display, and a bar graph.

Safety Information

A **Warning** identifies conditions and procedures that are dangerous to the user. A **Caution** identifies conditions and procedures that can cause damage to the Product or the equipment under test.

⚠️ Warning

To prevent possible electrical shock, fire, or personal injury.











- **Use the Product only as specified, or the protection supplied by the Product can be compromised.**
- **Comply with local and national safety codes. Use personal protective equipment (approved rubber gloves, face protection, and flame-resistant clothes) to prevent shock and arc blast injury where hazardous live conductors are exposed.**
- **Use Product-approved measurement category (CAT), voltage, and amperage rated accessories (probes, test leads, and adapters) for all measurements.**
- **Remove all probes, test leads, and accessories that are not necessary for the measurement.**
- **Do not use test leads if they are damaged. Examine the test leads for damaged insulation and measure a known voltage.**





Model 77 Series IV

Users Manual

- Do not use a current measurement as an indication that a circuit is safe to touch. A voltage measurement is necessary to know if a circuit is hazardous.
- Do not use the Product if it is damaged.
- Disable the Product if it is damaged.
- Do not use the Product above its rated frequency.
- Do not use in CAT III or CAT IV environments without the protective cap installed on test probe. The protective cap decreases the exposed probe metal to <4 mm. This decreases the possibility of arc flash from short circuits.
- Replace a blown fuse with exact replacement only for continued protection against arc flash.
- Do not use the HOLD function to measure unknown potentials. When HOLD is turned on, the display does not change when a different potential is measured.
- Attempting to make a measurement with a test lead in an incorrect terminal might blow a fuse, damage the Meter, and cause serious personal injury.

Symbols

Symbol	Description	Symbol	Description
	AC (Alternating Current)		Fuse
	DC (Direct Current)		Conforms to European Union directives
	DC/AC		Certified by CSA Group to North American safety standards.
	Earth		Double insulated
	WARNING. RISK OF DANGER.		WARNING. HAZARDOUS VOLTAGE. Risk of electric shock.

Symbol	Description	Symbol	Description
	Battery (Low battery when shown on display)		Consult user documentation.
	Certified by TÜV SÜD Product Service.		Conforms to relevant South Korean EMC Standards
	Conforms to relevant Australian EMC standards		
CAT II	Measurement Category II is applicable to test and measuring circuits connected directly to utilization points (socket outlets and similar points) of the low-voltage MAINS installation.		
CAT III	Measurement Category III is applicable to test and measuring circuits connected to the distribution part of the building's low-voltage MAINS installation.		
CAT IV	Measurement Category IV is applicable to test and measuring circuits connected at the source of the building's low-voltage MAINS installation.		

Unsafe Voltage

During a voltage measurement, the Meter alerts you to the presence of a potentially hazardous voltage. When the Meter detects a voltage ≥ 30 V or a voltage overload (**OL**), the ⚡ symbol is displayed.

Test Lead Alert

To remind you to check that the test leads are in the correct terminals, **LEAD** is momentarily displayed when you move the rotary switch *to* or *from* the **mA** or **A** position.

Battery Saver (Sleep Mode)

The Meter enters the "Sleep" mode and blanks out the display if there is no function change or button press for 20 minutes. To disable the Sleep mode, hold down the yellow button while turning the Meter on. The Sleep mode is always disabled in the MIN MAX AVG mode and the AutoHOLD mode.

Terminals

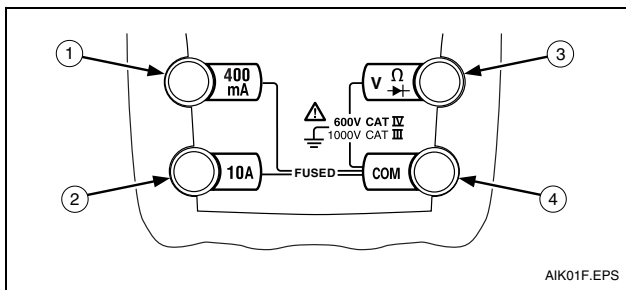

Item	Description
1	Input terminal for AC and DC milliamp measurements to 400 mA.
2	Input terminal for AC and DC current measurements to 10 A.
3	Input terminal for voltage, continuity, resistance, diode test, capacitance, and frequency measurements.
4	Common (return) terminal for all measurements.

Rotary Switch Positions

Switch Position	Measurement Function
\tilde{V} Hz	AC voltage from 0.001 to 1000 V. Frequency from 2 Hz to 99.99 kHz.
\bar{V}	DC voltage from 1 mV to 1000 V.
m \bar{V}	DC mV from 0.1 mV to 600 mV.
Ω ⊕	Ohms from 0.1 Ω to 50 M Ω . Farads from 1 nF to 9999 μ F.
))) ⊕	Beeper turns on at <25 Ω and turns off at >250 Ω . Diode test. Displays OL above 2.4 V.
≡ \tilde{A} mA	AC mA from 0.01 mA to 400 mA. DC mA from 0.01 mA to 400 mA.
≡ \tilde{A}	AC A from 0.001 A to 10 A. DC A from 0.001 A to 10 A >10.00 display flashes. >20 A, OL is displayed.

Display

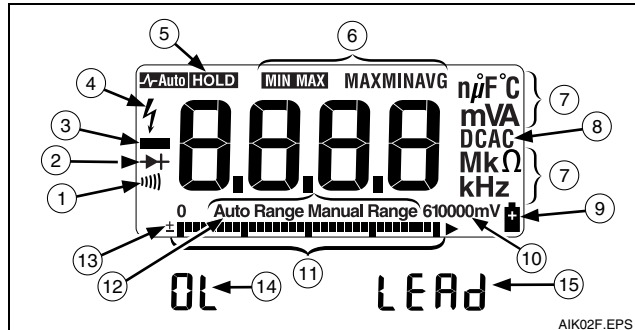

AIK02F.EPS

No.	Symbol	Meaning
1)))	Continuity test.
2	▶ +	Diode test.
3	—	Negative readings.
4	⚡	Unsafe voltage. Voltage ≥ 30 V, or voltage overload (OL)
5	HOLD	AutoHOLD is enabled. Display holds present reading until it detects new stable input. Then the Meter beeps and displays new reading.
6	MIN MAX MAX , MIN, AVG	MIN MAX AVG enabled. Maximum, minimum, average, or present reading.
7	nµ F, mVA, MkΩ, kHz	Measurement units.

No.	Symbol	Meaning
8	DC, AC	Direct current, alternating current.
9	+	Low battery. Replace battery.
10	610000mV	All possible ranges.
11	Bar graph	Analog display.
12	Auto Range Manual Range	The Meter selects the range with the best resolution. The user selects the range.
13	±	Bar graph polarity.
14	OL	The input out of range.
15	LEAD	⚠ Test lead alert. Displayed when the rotary switch is moved to or from the mA or A position.

Error Messages	
bAtt	Replace the battery immediately.
d/c	In the capacitance function, too much electrical charge is present on the capacitor being tested.
EEP-Err	Invalid EEPROM data. Have Meter serviced.
CAL Err	Invalid calibration data. Calibrate Meter.

MIN MAX AVG Recording Mode

The MIN MAX AVG recording mode captures the minimum and maximum input values, and calculates a running average of all readings. When a new high or low is detected, the Meter beeps.

Note

For dc functions, accuracy is the specified accuracy of the measurement function ± 12 counts for changes longer than 350 ms in duration.

For ac functions, accuracy is the specified accuracy of the measurement function ± 40 counts for changes longer than 350 ms in duration.

To use MIN MAX AVG recording:

- Make sure that the Meter is in the desired measurement function and range. (Autoranging is disabled in the MIN MAX AVG mode.)
- Press **MIN MAX** to activate MIN MAX AVG mode. **MIN MAX** and **MAX** light, and the highest reading detected since entering MIN MAX AVG is displayed.
- Press **MIN MAX** to step through the low (**MIN**), average (**AVG**), and present readings.
- To pause MIN MAX AVG recording without erasing stored values, press **HOLD**. **HOLD** is displayed.
- To resume MIN MAX AVG recording, press **HOLD** again. **HOLD** turns off.
- To exit and erase stored readings, press MIN MAX for 1 second or turn the rotary switch.

AutoHOLD Modes

⚠⚠ Warning

To avoid electric shock, do not use the AutoHOLD mode to determine if a circuit is live. Unstable or noisy readings will not be captured.

In the AutoHOLD mode, the Meter holds the reading on the display until it detects a new stable reading. Then the Meter beeps, and displays the new reading.

- Press **HOLD** to activate AutoHOLD. **HOLD** lights.
- Press **HOLD** again or turn the rotary switch to resume normal operation.

YELLOW Button

Press the yellow button to select alternate measurement functions on a rotary switch setting, e.g., to select DC mA, DC A, Hz, capacitance, or diode test.

Display Backlight

Press  to toggle the backlight on and off. The backlight automatically turns off after 2 minutes.

Manual Ranging and Autoranging

The Meter has both Manual range and Autorange modes.

- In the Autorange mode, the Meter selects the range with the best resolution.
- In the Manual Range mode, you override Autorange and select the range yourself.

When you turn the Meter on, it defaults to Autorange and **Auto Range** is displayed.

1. To enter the Manual Range mode, press **RANGE**. **Manual Range** is displayed.
2. In the Manual Range mode, press **RANGE** to increment the range. After the highest range, the Meter wraps to the lowest range.

Note

You cannot manually change the range in the MIN MAX AVG mode.





*If you press **RANGE** while in MIN MAX_AVG, the Meter beeps twice, indicating an invalid operation, and the range does not change.*

3. To exit Manual Range, press **RANGE** for 1 second or turn the rotary switch.
The Meter returns to Autorange and **Auto Range** is displayed.

Power-Up Options

To select a Power-Up Option, hold down the button indicated while turning the Meter on.

Power-Up Options are cancelled when the Meter is turned OFF.

Button	Power-Up Options
	Turns on all display segments when in VAC switch position.
	Disables beeper. bEEP is displayed when enabled.
	Enables "Smoothing" mode. 5--- is displayed when enabled. Dampens display fluctuations of rapidly changing inputs by digital filtering.
 (YELLOW)	Disables automatic power-down ("Sleep mode"). PoFF is displayed when enabled Sleep mode is also disabled while the Meter is in a MIN MAX AVG Recording mode, or the AutoHOLD mode.
	Disables automatic 2-minute backlight timeout. LoFF is displayed when enabled.

Making Basic Measurements

The figures on the following pages show how to make basic measurements.

When connecting the test leads to the circuit or device, connect the common (**COM**) test lead before connecting the live lead; when removing the test leads, remove the live lead before removing the common test lead.

⚠⚠ Warning

To avoid electric shock or injury, or damage to the Meter, disconnect circuit power and discharge all high-voltage capacitors before testing resistance, continuity, diodes, or capacitance.

Measuring AC and DC Voltage

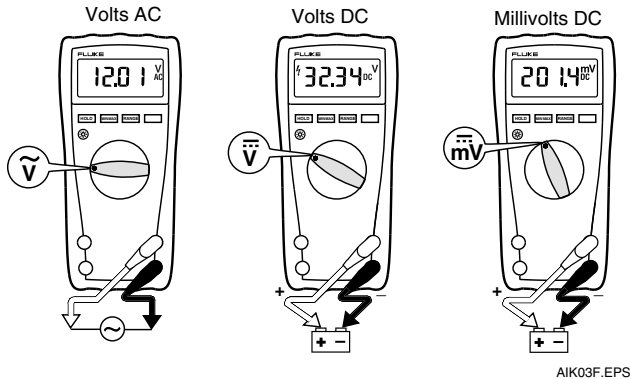

Measuring Resistance

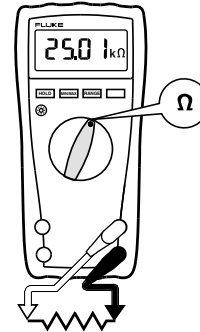

Measuring Capacitance

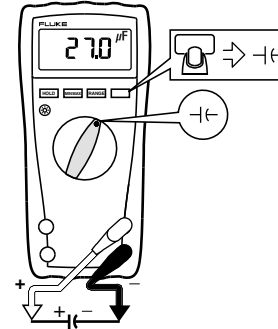

Testing for Continuity

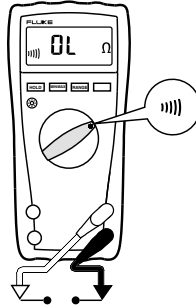
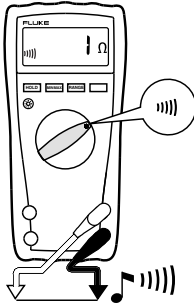

AIK06F.EPS

Testing Diodes

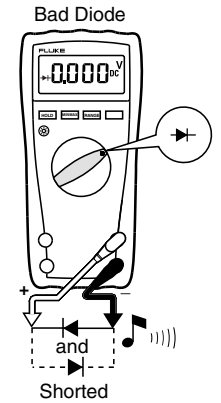
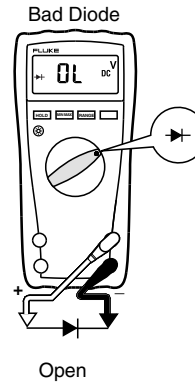
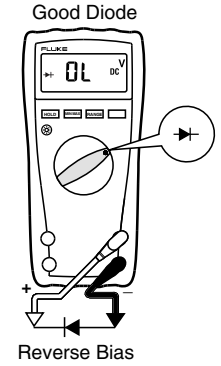
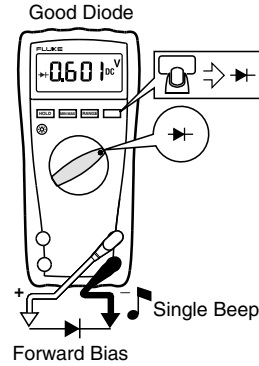

AIK07F.EPS

Measuring AC or DC Current

⚠⚠ Warning

To avoid personal injury or damage to the Meter:

- Never attempt to make an in-circuit current measurement when the open-circuit potential to earth ground is >1000 V.
- Check the Meter's fuses before testing. (See "Testing the Fuses".)
- Use the proper terminals, switch position, and range for your measurement.
- Never place the probes in parallel with a circuit or component when the leads are plugged into the current terminals.

Turn power OFF, break circuit, insert Meter in series, turn power on.

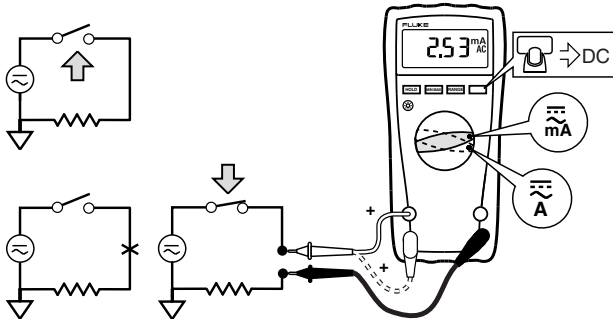

AIK08F.EPS

Measuring Frequency

⚠⚠ Warning

To avoid electrical shock, disregard the bar graph for frequencies >1 kHz. If the frequency of the measured signal is >1 kHz, the bar graph is unspecified.

The Meter measures the frequency of a signal. The trigger level is 0 V ac for all ranges.

AC Voltage Frequency

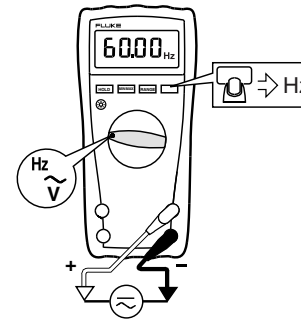

EOM09F.EPS

- To exit frequency, press yellow button or turn the rotary switch.
- In frequency, the bar graph shows the ac voltage accurately up to 1 kHz.
- Select progressively lower ranges using manual ranging for a stable reading.

Using the Bar Graph

The bar graph is like the needle on an analog Meter. There is an overload indicator (▶) to the right, and a polarity indicator (±) to the left.

Because the bar graph is much faster than the digital display, the bar graph is useful for making peak and null adjustments, and for observing rapidly changing inputs.

The bar graph is disabled when measuring capacitance. In frequency, the bar graph accurately indicates the voltage or current up to 1 kHz.

The number of lit segments indicates the measured value and is relative to the full-scale value of the selected range.

For example, in the 60 V range (see below), the major divisions on the scale represent 0, 15, 30, 45, and 60 V. An input of -30 V lights the negative sign and the segments up to the middle of the scale.



AIK11F.EPS

Cleaning

Wipe the case with a damp cloth and mild detergent. Do not use abrasives or solvents. Dirt or moisture in the terminals can affect readings.

Testing the Fuses

⚠⚠ Warning

To avoid electrical shock or injury, remove the test leads and any input signals before replacing the fuse.

Test fuses as shown below.

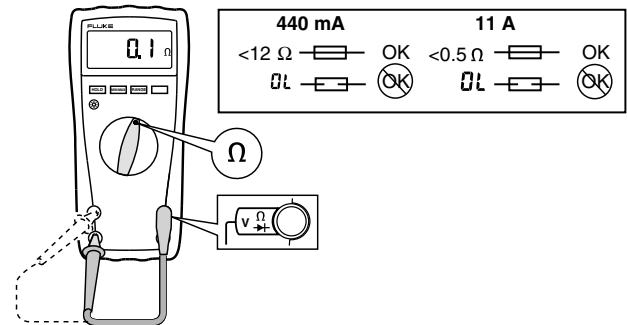

AIK12F.EPS

Replacing the Battery and Fuses

⚠⚠ Warning

To avoid shock, injury, or damage to the Meter:

- Use **ONLY** fuses with the amperage, interrupt, voltage, and speed ratings specified. Disconnect test leads before opening case.

AIK13F.EPS

F1 Fuse, 440 mA, 1000 V, FAST	Fluke PN 943121
F2 Fuse, 11 A, 1000 V, FAST	Fluke PN 803293
B1 Battery, 9 V Alkaline, NEDA 1604 / 1604A	Fluke PN 614487

General Specifications

Accuracy is specified for 1 yr after calibration, at operating temperatures of 18 °C to 28 °C, with relative humidity at 0 % to 90 %. Accuracy specifications take the form of $\pm([\% \text{ of Reading}] + [\text{Counts}])$.

- Maximum voltage between any terminal and earth ground** 1000 V
- Fuse protection for mA inputs** 0.44 A, 1000 V, IR 10 kA
- Fuse protection for A inputs** 11 A, 1000 V, IR 17 kA FAST Fuse

Display

- Digital 6000 counts, updates 4/sec
- Bar Graph 33 segments; Updates 32/sec
- Frequency 10,000 counts
- Capacitance 1,000 counts

Altitude

- Operating 2,000 meters
- Storage 12,000 meters

Temperature

- Operating -10 °C to +50 °C
- Storage -40 °C to +60 °C

Temperature coefficient 0.1 X (specified accuracy) / °C (< 18 °C or > 28 °C)

Safety

- General IEC 61010-1: Pollution Degree 2
- Measurement IEC 61010-2-033: CAT IV 600 V / CAT III 1000 V

Relative Humidity (Maximum Non-condensing) 90 % to 35 °C
75 % to 40 °C
45 % to 50 °C

Battery Life 400 hrs typical (Alkaline)

Size (H x W x L) 4.3 cm x 9 cm x 18.5 cm

Weight 420 g

Electromagnetic Compatibility (EMC)

International IEC 61326-1: Portable Electromagnetic Environment, IEC 61326-2-2.

CISPR 11: Group 1, Class A

Group 1: Equipment has intentionally generated and/or uses conductively-coupled radio frequency energy that is necessary for the internal function of the equipment itself.

Class A: Equipment is suitable for use in all establishments other than domestic and those directly connected to a low-voltage power supply network that supplies buildings used for domestic purposes. There may be potential difficulties in ensuring electromagnetic compatibility in other environments due to conducted and radiated disturbances.

Emissions that exceed the levels required by CISPR 11 can occur when the equipment is connected to a test object.

Korea (KCC) Class A Equipment (Industrial Broadcasting & Communication Equipment)

Class A: Equipment meets requirements for industrial electromagnetic wave equipment and the seller or user should take notice of it. This equipment is intended for use in business environments and not to be used in homes.

USA (FCC)..... 47 CFR 15 subpart B. This product is considered an exempt device per clause 15.103.

Digital Multimeter
General Specifications

Function	Range	Resolution	Accuracy \pm ([% of Reading] + [Counts])
AC Volts (Average responding)	6.000 V 60.00 V 600.0 V 1000 V	0.001 V 0.01 V 0.1 V 1 V	2.0 % + 2 (45 Hz to 1 kHz)
DC mV	600.0 mV	0.1 mV	0.3 % + 1
DC Volts	6.000 V 60.00 V 600.0 V 1000 V	0.001 V 0.01 V 0.1 V 1 V	0.3 % + 1
Continuity	600 Ω	1 Ω	Meter beeps at <25 Ω , beeper turns off at >250 Ω ; detects opens or shorts of 250 μ s or longer.
Ohms	600.0 Ω 6.000 k Ω 60.00 k Ω 600.0 k Ω 6.000 M Ω 50.00 M Ω	0.1 Ω 0.001 k Ω 0.01 k Ω 0.1 k Ω 0.001 M Ω 0.01 M Ω	0.5 % + 2 0.5 % + 1 0.5 % + 1 0.5 % + 1 0.5 % + 1 2.0 % + 1
Diode test	2.400 V	0.001 V	1 % + 2
Capacitance	1000 nF 10.00 μ F 100.0 μ F 9999 μ F ^[1]	1 nF 0.01 μ F 0.1 μ F 1 μ F	1.2 % + 2 1.2 % + 2 1.2 % + 2 10 % typical
AC Amps (Average responding) ^[2]	60.00 mA 400.0 mA ^[3] 6.000 A 10.00 A ^[4]	0.01 mA 0.1 mA 0.001 A 0.01 A	2.5 % + 2 (45 Hz to 1 kHz)
<p>[1] In the 9999 μF range for measurements to 1000 μF, the measurement accuracy is 1.2 % + 2. [2] Amps input burden voltage (typical): 400 mA input 2 mV/mA, 10 A input 37 mV/A. [3] 400.0 mA accuracy specified up to 600 mA overload. [4] >10 A unspecified.</p>			

Model 77 Series IV*Users Manual*

Function	Range	Resolution	Accuracy \pm ([% of Reading] + [Counts])
DC Amps ^[3]	60.00 mA 400.0 mA ^[4] 6.000 A 10.00 A ^[5]	0.01 mA 0.1 mA 0.001 A 0.01 A	1.5 % + 2
Hz ^{[1][2]} (ac voltage input)	99.99 Hz 999.9 Hz 9.999 kHz 99.99 kHz	0.01 Hz 0.1 Hz 0.001 kHz 0.01 kHz	0.1 % + 1
MIN MAX AVG	For dc functions, accuracy is the specified accuracy of the measurement function ± 12 counts for changes longer than 350 ms in duration. For ac functions, accuracy is the specified accuracy of the measurement function ± 40 counts for changes longer than 350 ms in duration.		
[1]	Frequency is specified from 2 Hz to 99.99 kHz.		
[2]	Below 2 Hz, the display shows zero Hz.		
[3]	Amps input burden voltage (typical): 400 mA input 2 mV/mA, 10 A input 37 mV/A.		
[4]	400.0 mA accuracy specified up to 600 mA overload.		
[5]	>10 A unspecified.		

Function	Overload Protection ^[1]	Input Impedance (Nominal)	Common Mode Rejection Ratio (1 k Ω Unbalanced)		Normal Mode Rejection
Volts AC	1000 V	>10 M Ω <100 pF	>60 dB @ dc, 50 Hz or 60 Hz		
Volts DC	1000 V	>10 M Ω <100 pF	>120 dB @ dc, 50 Hz or 60 Hz		>60 dB @ 50 Hz or 60 Hz
mV	1000 V ^[2]	>10 M Ω <100 pF	>120 dB @ dc, 50 Hz or 60 Hz		>60 dB @ 50 Hz or 60 Hz
		Open Circuit Test Voltage	Full Scale Voltage To: 6.0 M Ω 50 M Ω		Short Circuit Current
Ohms/Capacitance	1000 V ^[2]	<8.0 V dc	<660 mV dc	<4.6 V dc	<1.1 mA
Continuity/Diode test	1000 V ^[2]	<8.0 V dc	2.4 V dc		<1.1 mA
<p>[1] 10⁷ V-Hz maximum. [2] For circuits <0.3 A short circuit. 660 V for high energy circuits.</p>					

Function	Overload Protection	Overload
mA	Fused, 440 mA, 1000 V FAST Fuse	600 mA overload for 2 minutes maximum, 10 minutes rest.
A	Fused, 11 A, 1000 V FAST Fuse	20 A overload for 30 seconds maximum, 10 minutes rest.

