

# **in**LINE<sup>®</sup>

TRACTION • CONTROL • SYSTEM

## Owner's Manual

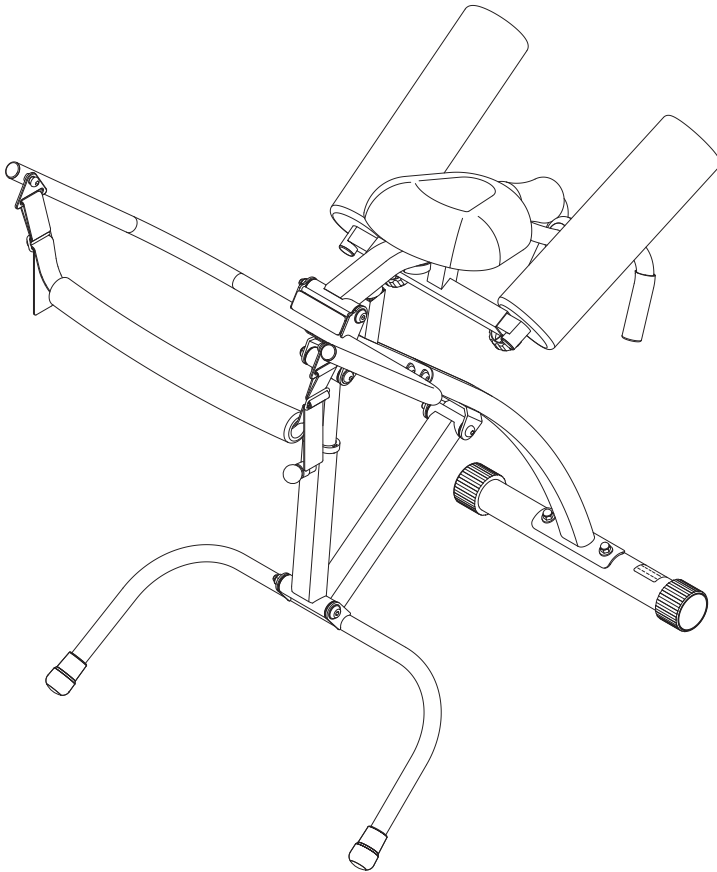

Product May Vary Slightly From Pictured.

**CAUTION:**  
Weight on this product should not exceed 250 lbs.

### **⚠ WARNING**

Exercise can present a health risk. Consult a physician before beginning any exercise program with this equipment. If you feel faint or dizzy, immediately discontinue use of this equipment. Serious bodily injury can occur if this equipment is not assembled and used correctly. Serious bodily injury can also occur if all instructions are not followed. Keep others and pets away from equipment when in use. Always make sure all bolts and nuts are securely tightened prior to each use. Follow all safety instructions in this manual.

When calling for parts or service, please specify the following number:

**Model#: 20-4800A**

This Product is Distributed Exclusively by



2040 N. Alliance, Springfield, MO 65803  
Customer Service  
1 (800) 375-7520  
[www.staminaproducts.com](http://www.staminaproducts.com)

**STAMINA PRODUCTS**  
MADE IN CHINA

© 2015 Stamina Products, Inc.  
2015, 03

## TABLE OF CONTENTS

Safety Instructions .....	2	Storage .....	15
Before You Begin .....	4	Maintenance .....	15
Equipment Warning, Caution & Notice Labels ...	5	Product Parts Drawing .....	16
Hardware Identification Chart .....	6	Parts List .....	17
Assembly Instructions .....	7	Warranty .....	18
Operational Instructions .....	12	Fax/Mail Ordering Form .....	19

## SAFETY INSTRUCTIONS

**⚠ WARNING** This product contains a chemical known to the State of California to cause cancer and birth defects or other reproductive harm.

**⚠ CAUTION** Consult your physician before starting this or any exercise program. This is especially important if you are over the age of 35, have never exercised before, are pregnant, or suffer from any health problem. This product is for home use only. Do not use in institutional or commercial applications. Failure to follow all warnings and instructions could result in bodily injury and property damage.

**⚠ WARNING** To reduce the risk of serious injury, read the following Safety Instructions before using the inLine® Traction Control System.

1. Save these instructions and ensure that other exercisers read this manual prior to using the **inLine® Traction Control System** for the first time.
2. Read all warnings and cautions posted on the **inLine® Traction Control System**.
3. The **inLine® Traction Control System** should only be used after a thorough review of the Owner's Manual. Make sure that it is properly assembled and tightened before use.
4. We recommend that two people be available for assembly of this product.
5. Keep children away from the **inLine® Traction Control System**. Do not allow children to use or play on the **inLine® Traction Control System**. Keep children and pets away from the **inLine® Traction Control System** when it is in use.
6. It is recommended that you place this exercise equipment on an equipment mat.
7. Set up and operate the **inLine® Traction Control System** on a solid level surface. Do not position the **inLine® Traction Control System** on loose rugs or uneven surfaces.
8. Make sure that adequate space is available for access to and around the **inLine® Traction Control System**.
9. Before using, inspect the **inLine® Traction Control System** for worn or loose components, and securely tighten or replace any worn or loose components prior to use.
10. Before using, always check the Main Frame(14). The Spring Pin(12) must be inserted into one of the adjustment holes in the Inner Tube(13) and locked into position before use.
11. Consult a physician prior to commencing an exercise program and follow his/her recommendations in developing your fitness program. If at any time during exercise you feel faint, dizzy, or experience pain, stop and consult your physician.
12. Always choose the workout which best fits your physical strength and flexibility level. Know your limits and train within them. Always use common sense when exercising.
13. Do not wear loose or dangling clothing while using the **inLine® Traction Control System**.
14. Never exercise in bare feet or socks; always wear proper footwear such as running, walking, or cross training shoes that fit well, provide foot support, and feature non-skid rubber soles.
15. Be careful to maintain your balance while using, mounting, dismounting, or assembling the **inLine® Traction Control System**, loss of balance may result in a fall and bodily injury.
16. The **inLine® Traction Control System** should not be used by persons weighing over 250 pounds.
17. The **inLine® Traction Control System** should be used by only one person at a time.
18. The **inLine® Traction Control System** is for consumer use only. It is not for use in public or semipublic facilities.

# Call Us First



**Customer Service**  
**1 (800) 375-7520**  
**www.staminaproducts.com**

## THANK YOU FOR PURCHASING THE inLine® Traction Control System

To enact your warranty, please register your product  
by going to [register.staminaproducts.com](http://register.staminaproducts.com)

Your inLine® Traction Control System does require assembly.  
Please follow the assembly steps set forth in this manual.  
With regular workouts, you will be getting your body into shape  
and be on your way to achieving a happier and healthier lifestyle.

Should you have any questions,  
please call our Customer Service Department toll-free number,  
**1 (800) 375-7520**

Monday - Thursday, 7:30 A.M. - 5:00 P.M., Central Time.  
Friday, 8:00 A.M. - 3:00 P.M., Central Time.



**ONLINE**

CUSTOMER SERVICE  
[customerservice@staminaproducts.com](mailto:customerservice@staminaproducts.com)  
[www.staminaproducts.com](http://www.staminaproducts.com)



**TELEPHONE**

CUSTOMER SERVICE  
Tel: 1 (800) 375-7520



**FAX**

CUSTOMER SERVICE  
Fax: (417) 889-8064



**MAIL**

STAMINA PRODUCTS, INC.  
ATTN: Customer Service  
P.O. Box 1071  
Springfield, MO. 65801-1071



## BEFORE YOU BEGIN

Thank you for choosing the **inLine® Traction Control System**. We take great pride in producing this quality product and hope it will provide many hours of quality exercise to make you feel better, look better, and enjoy life to its fullest.

It's a proven fact that a regular exercise program can improve your physical and mental health. Too often, our busy lifestyles limit our time and opportunity to exercise. The **inLine® Traction Control System** provides a convenient and simple method to begin your journey of getting your body in shape and achieving a happier and healthier lifestyle.

Before reading further, please review the drawing below and familiarize yourself with the parts that are labeled.

Read this manual carefully before using the **inLine® Traction Control System**.

Although Stamina constructs its products with the finest materials and uses the highest standards of manufacturing and quality control, there can sometimes be missing parts or incorrectly sized parts. If you have any questions or problems with the parts included with your **inLine® Traction Control System**, please do not return the product. Contact us **FIRST!**

If a part is missing or defective, please go to [staminaproducts.com](http://staminaproducts.com) under the Service section and order the part needed, or call us toll free at 1-800-375-7520 (in the U.S.). Our Customer Service Staff is available to assist you from 7:30 A.M. to 5:00 P.M. (Central Time) Monday through Thursday and 8:00 A.M. to 3:00 P.M. (Central Time) on Friday.

Be sure to have the name and model number of the product available when you contact us.

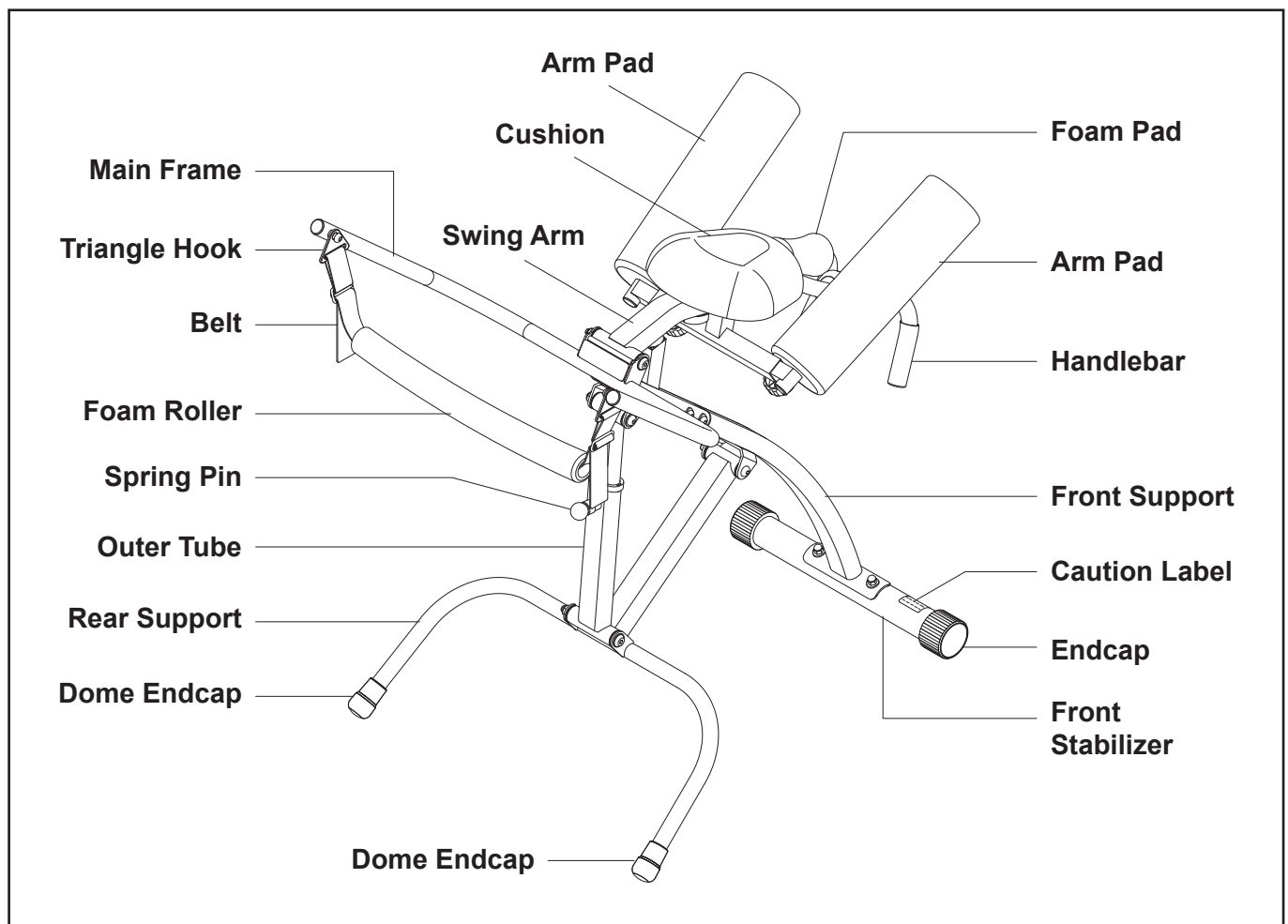

THE FOLLOWING TOOLS ARE INCLUDED FOR ASSEMBLY:



Allen Wrench (6mm)

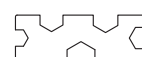

Wrench

## EQUIPMENT WARNING, CAUTION & NOTICE LABELS

This chart is provided to help identify the warning, caution, and notice labels on the **inLine® Traction Control System**. Please take a moment to familiarize yourself with all of the warning, caution, and notice labels.

Label is larger than actual size

### **C1** CAUTION LABEL(38)



# HARDWARE IDENTIFICATION CHART

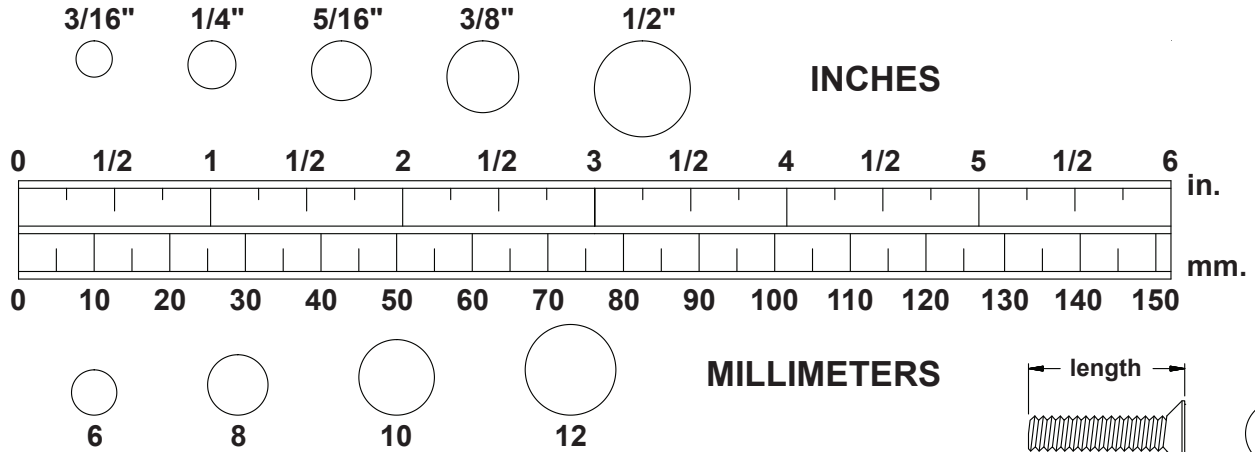

This chart is provided to help identify the hardware used in the assembly process. Place the washers or the ends of the bolts or screws on the circles to check for the correct diameter. Use the small scale to check the length of the bolts and screws.

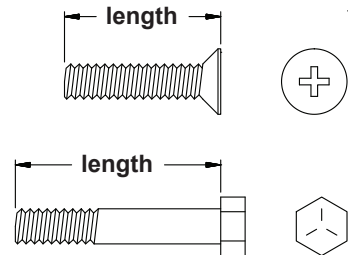

**NOTICE:** The length of all bolts and screws, except those with flat heads, is measured from below the head to the end of the bolt or screw. Flat head bolts and screws are measured from the top of the head to the end of the bolt or screw.

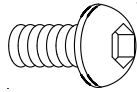
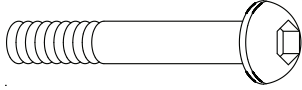
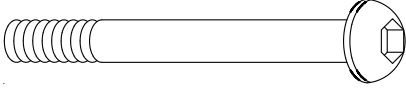
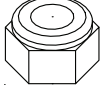
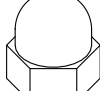
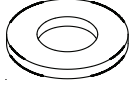

After unpacking the unit, open the hardware bag and make sure that you have all the following items. Some hardware may be already attached to the part.

	Part Number and Description	Qty
	27 Bolt, Button Head (M8 x 1.25 x 15mm)	11
	28 Bolt, Button Head (M8 x 1.25 x 60mm)	2
	29 Bolt, Button Head (M10 x 1.5 x 95mm)	2
	30 Bolt, Button Head (M10 x 1.5 x 125mm)	1
	31 Nylock Nut (M10 x 1.5)	3
	32 Acorn Nut (M8 x 1.25)	2
	33 Washer (M8)	1
	34 Washer (M10)	6
	35 Arc Washer (M8)	10

## ASSEMBLY INSTRUCTIONS

Place all parts from the box in a cleared area and position them on the floor in front of you. Remove all packing materials from your area and place them back into the box. Do not dispose of the packing materials until assembly is completed. Read each step carefully before beginning. If you are missing a part, please go to [staminaproducts.com](http://staminaproducts.com) under the Service section and order the part needed, e-mail us at [customerservice@staminaproducts.com](mailto:customerservice@staminaproducts.com), or call us toll free at 1-800-375-7520 (in the U.S.). Our Customer Service Staff is available to assist you from 7:30 A.M. to 5:00 P.M. (Central Time) Monday through Thursday and 8:00 A.M. to 3:00 P.M. (Central Time) on Friday.

### STEP 1

Attach the **FRONT STABILIZER(1)** to the **FRONT SUPPORT(2)** with **BUTTON HEAD BOLTS (M8x1.25x60mm)(28)**, **ARC WASHERS(M8)(35)**, and **ACORN NUTS(M8x1.25)(32)**.

### STEP 2

Insert the **FRONT SUPPORT(2)** into the **MAIN FRAME(14)** and secure with **BUTTON HEAD BOLTS(M8x1.25x15mm)(27)**, **ARC WASHERS(M8)(35)**, and **WASHER(M8)(33)**.

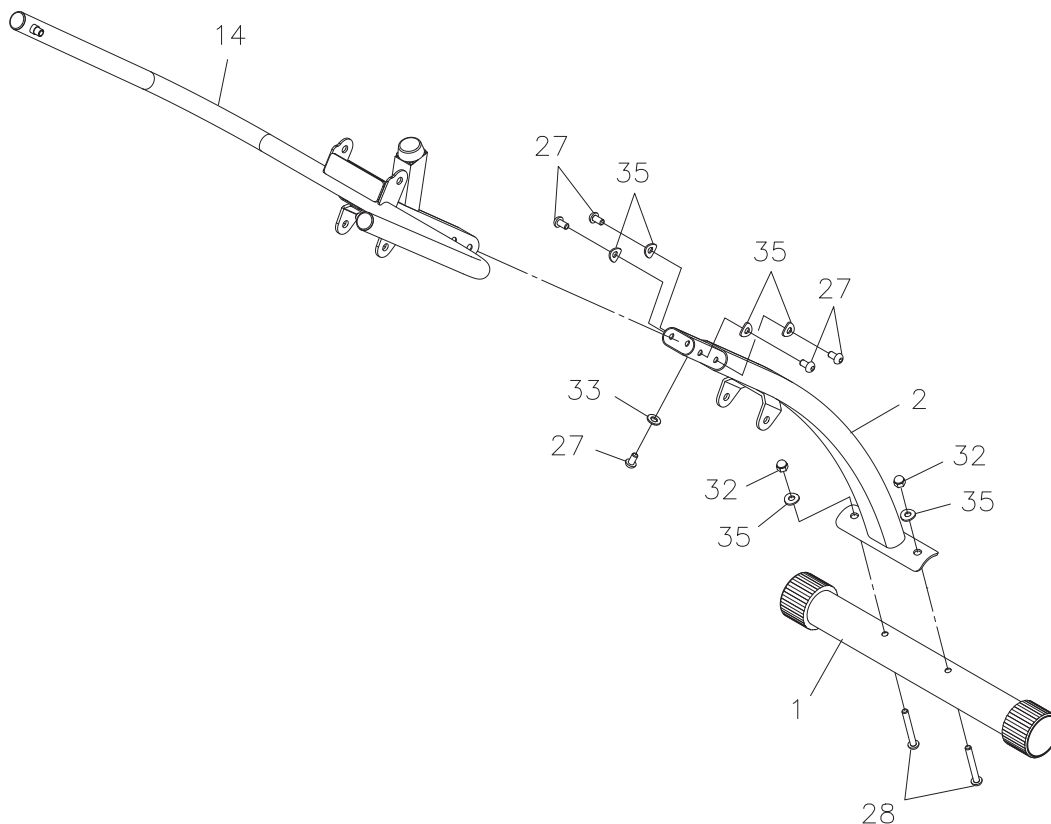

## ASSEMBLY INSTRUCTIONS

### STEP 3

Attach the **REAR SUPPORT(10)** to the **FRONT SUPPORT(2)** with **BUTTON HEAD BOLT (M10x1.5x95mm)(29)**, **WASHERS(M10)(34)**, and **NYLOCK NUT(M10x1.5)(31)**.

### STEP 4

Attach the **INNER TUBE(43)** to the **MAIN FRAME(14)** with **BUTTON HEAD BOLT(M10x1.5x95mm)(29)**, **WASHERS(M10)(34)**, and **NYLOCK NUT(M10x1.5)(31)**.

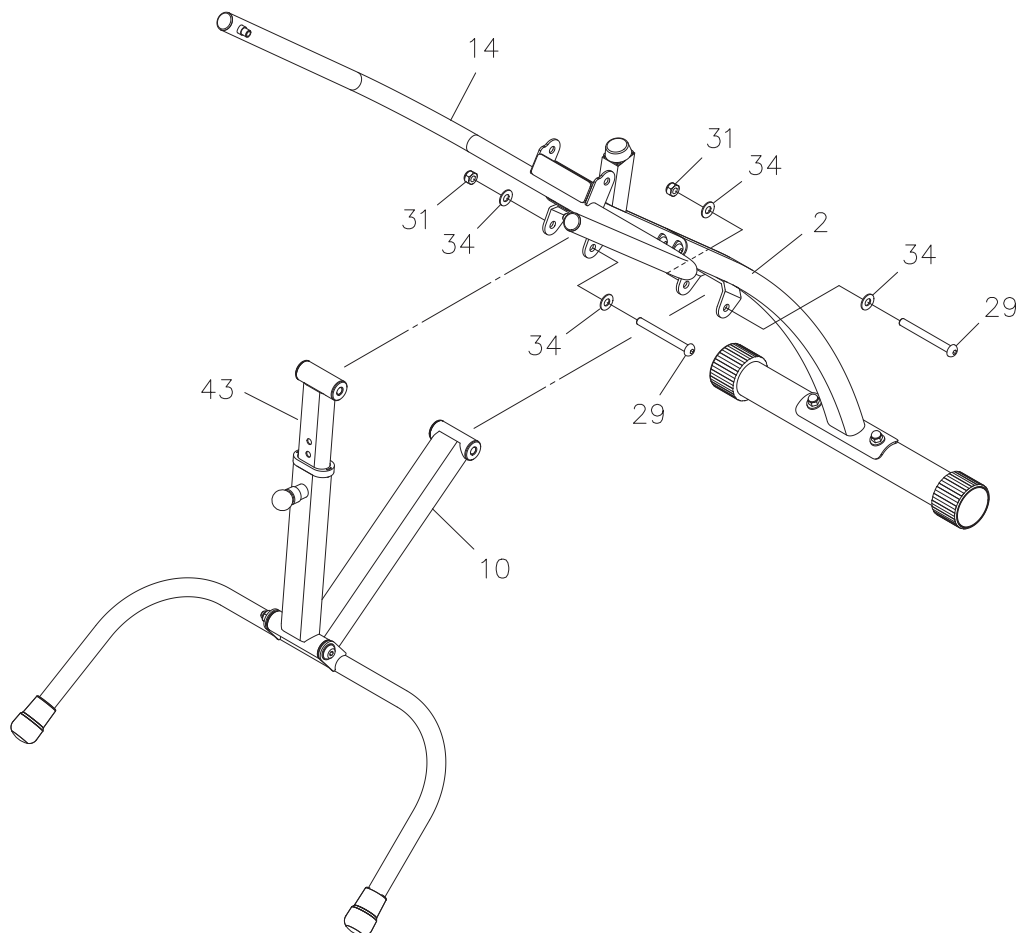

## ASSEMBLY INSTRUCTIONS

### STEP 5

Attach the **SWING ARM(8)** to the **MAIN FRAME(14)** with **BUTTON HEAD BOLT(M10x1.5x125mm)(30)**, **WASHERS(M10)(34)**, and **NYLOCK NUT(M10x1.5)(31)**.

### STEP 6

Insert the **HANDLEBAR(5)** into the **SWING ARM(8)** and secure with **BUTTON HEAD BOLTS (M8x1.25x15mm)(27)**, and **ARC WASHERS(M8)(35)**.

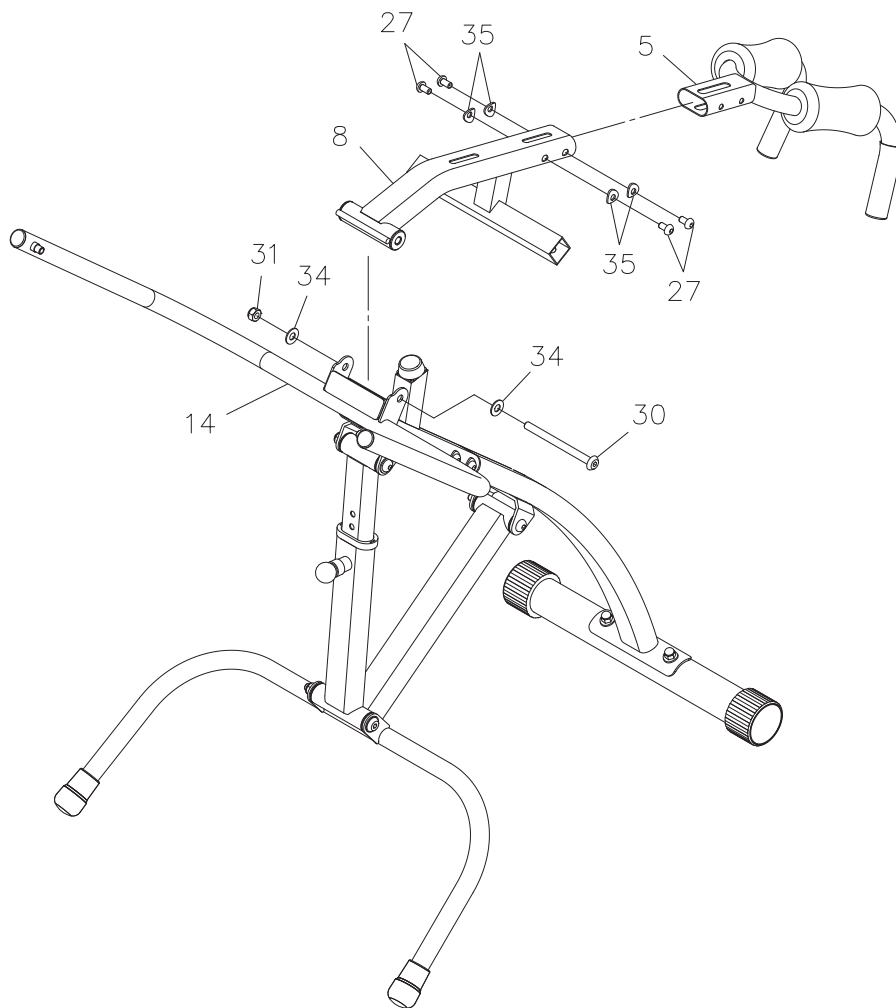

## ASSEMBLY INSTRUCTIONS

### STEP 7

Attach the **CUSHION(6)** to the **SWING ARM(8)** with the **LOCKING KNOBS(9)**.

### STEP 8

Insert the **LEFT** and **RIGHT ARM PAD TUBES(3, 4)** into both sides of the **SWING ARM(8)** and lock in position with the **ADJUSTMENT KNOB(7)**.

**NOTE:** The pin of the **ADJUSTMENT KNOBS(7)** must be inserted into one of the adjustment holes in the **LEFT** and **RIGHT ARM PAD TUBES(3, 4)** and use the same adjustment hole position on both sides.

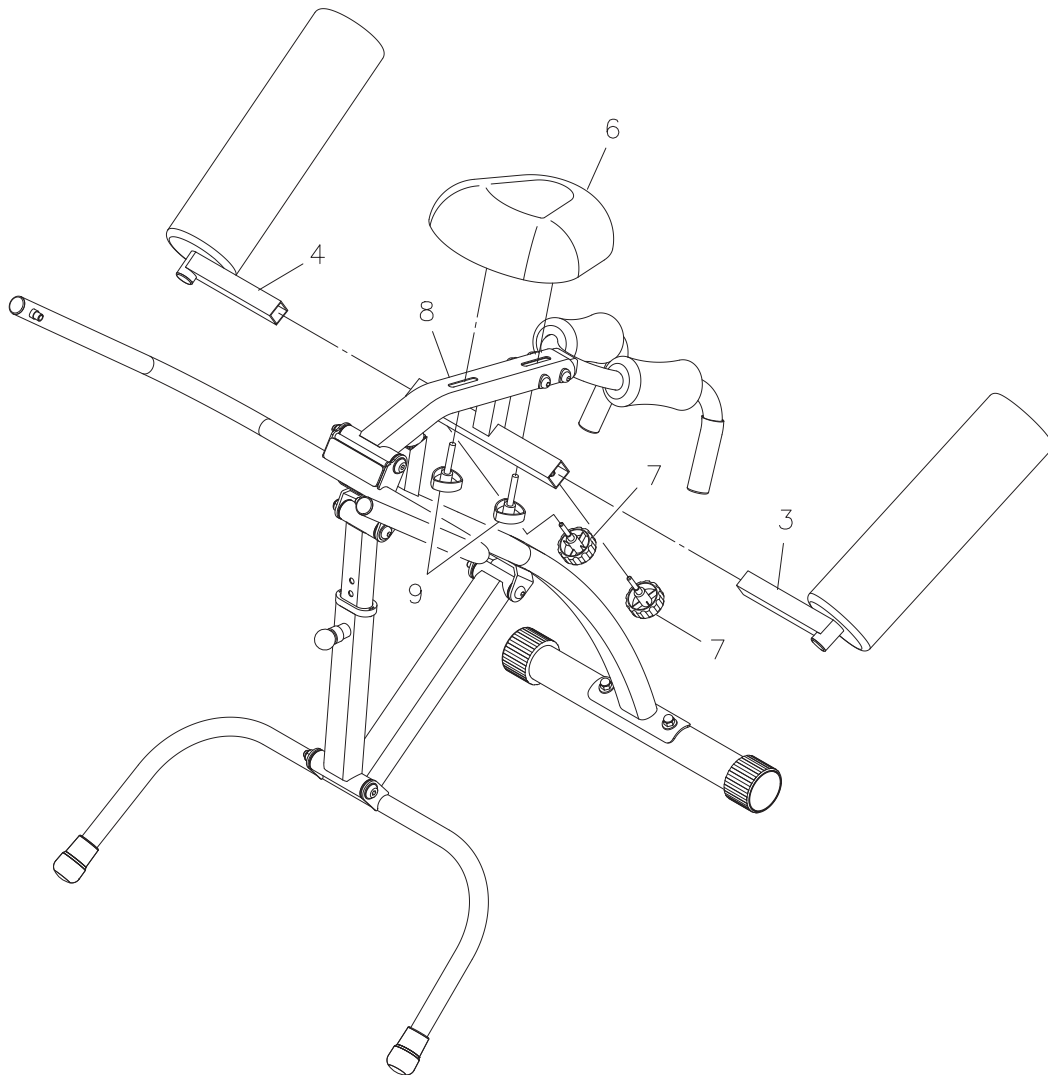

## ASSEMBLY INSTRUCTIONS

### STEP 9

Refer to the illustration below. Position the **BELT(25)** with its two ends to the outside. Install the **BELT(25)** by attaching the **TRIANGLE HOOKS(19)** to the **MAIN FRAME(14)** with **BUTTON HEAD BOLTS(M8x1.25x15mm)(27)**.

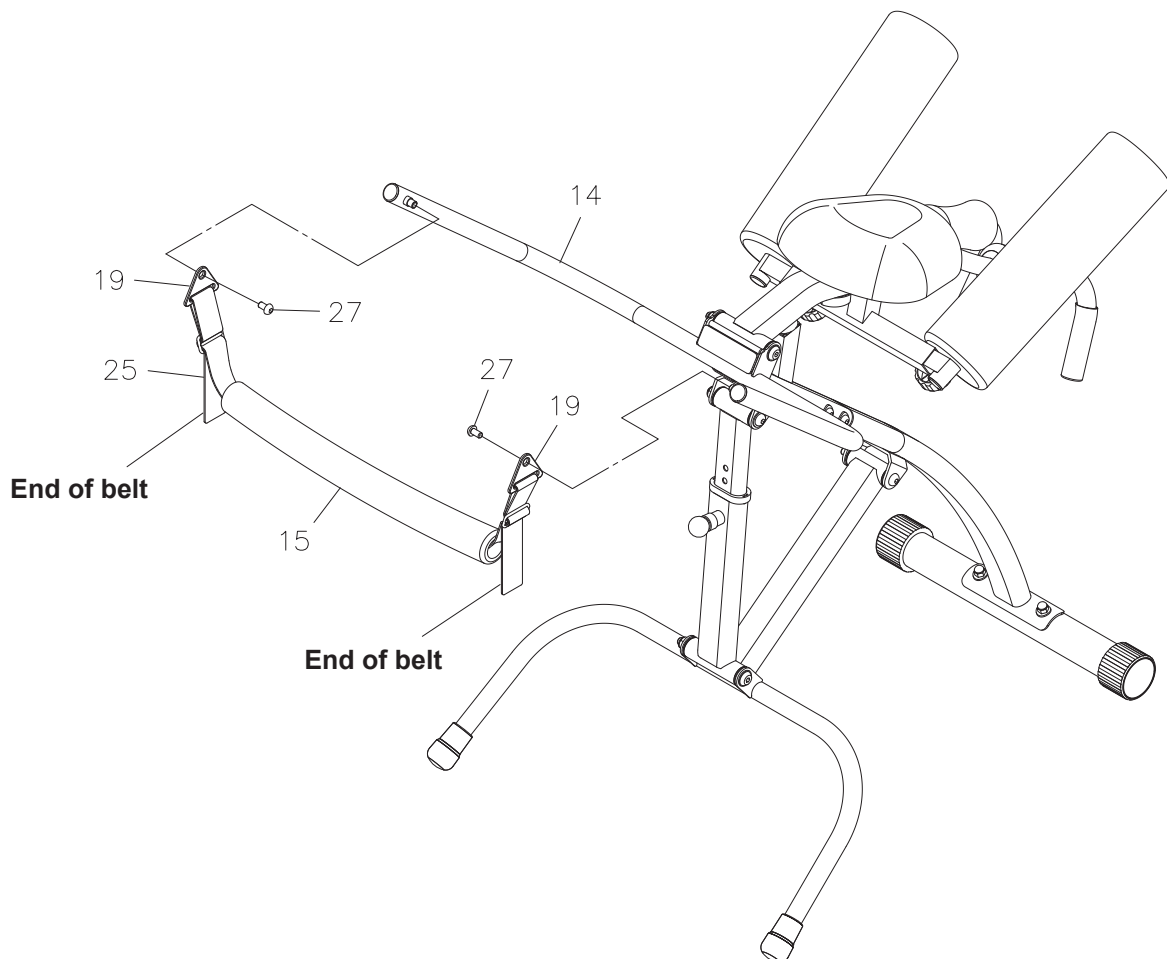

## OPERATIONAL INSTRUCTIONS

To use the inLine® Traction Control System, proper set up and adjustment of the inLine® Traction Control System is important for a revitalizing stretch.

### HEIGHT ADJUSTMENT

Refer to illustration A. The proper height of the inLine® Traction Control System for stretching is to match the pivot of the **BELT(25)** on the **MAIN FRAME(14)** to your body pivot point at the hip.

To make a height adjustment, pull the **SPRING PIN(12)** and slide the **INNER TUBE(43)** to adjust. Lock the **INNER TUBE(43)** in desired position by inserting the **SPRING PIN(12)** into one of the adjustment holes in the **INNER TUBE(43)**.

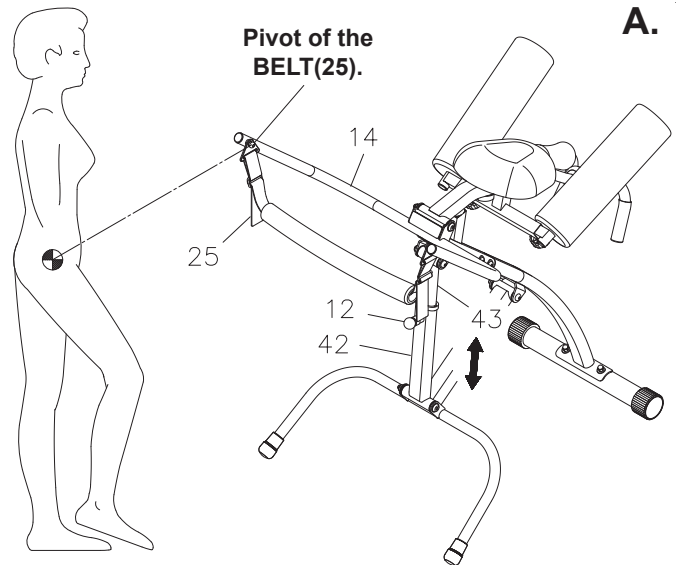

### FOAM ROLLER(15)/BELT(25) ADJUSTMENT

The **FOAM ROLLER(15)** and **BELT(25)** are used to control the stretching amount and adjusts to fit the different size of the users. Refer to illustration B and the detail view to adjust the length of the **BELT(25)** at the **BUCKLES(16)** on both sides.

Refer to illustration C. If you are an average height person, start with setting the **FOAM ROLLER(15)** in the middle position of the U shaped brace of the **MAIN FRAME(14)** and adjust if necessary.

1. Adjust the **FOAM ROLLER(15)** closer to the pivot of the **BELT(25)** if you are taller than average or you want to increase the amount of stretching.
2. Adjust the **FOAM ROLLER(15)** closer to the front edge of the **MAIN FRAME(14)** if you are shorter than average or you want to reduce the amount of stretching amount.

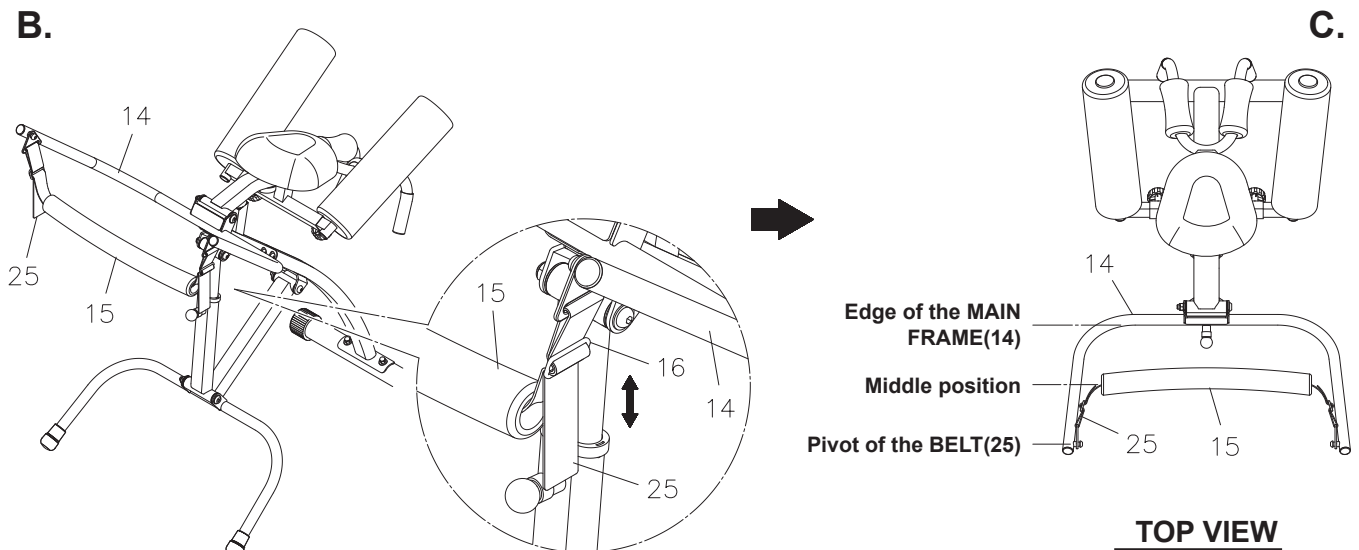

## OPERATIONAL INSTRUCTIONS

### ARM PAD(20) ADJUSTMENT

The width between the two **ARM PADS(20)** must be adjusted properly to fit the width of your upper body. The back of your upper arms should rest on the **ARM PADS(20)** during use.

To adjust, remove the **ADJUSTMENT KNOBS(7)** and slid the **LEFT** and **RIGHT ARM TUBES(3, 4)** to the desired position. Insert the pin of the **ADJUSTMENT KNOBS(7)** into one of the adjustment holes in the **LEFT** and **RIGHT ARM PAD TUBES(3, 4)** and tighten securely. Use the same adjustment hole position on both sides.

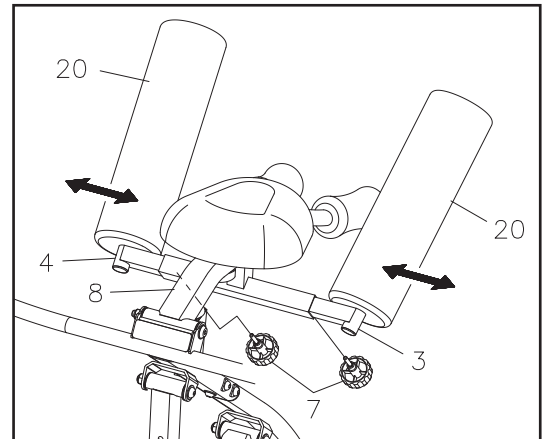

### CUSHION(6) ADJUSTMENT

The position of the **CUSHION(6)** is adjustable. Place the **CUSHION(6)** at the position which is most comfortable for supporting your chest when stretching on the **inLine® Traction Control System**.

Adjust the **CUSHION(6)** by loosening, but not removing, the **LOCKING KNOBS(9)** and sliding the **CUSHION(6)** to desired position. Tighten the **LOCKING KNOBS(9)** to lock the **CUSHION(6)** securely.

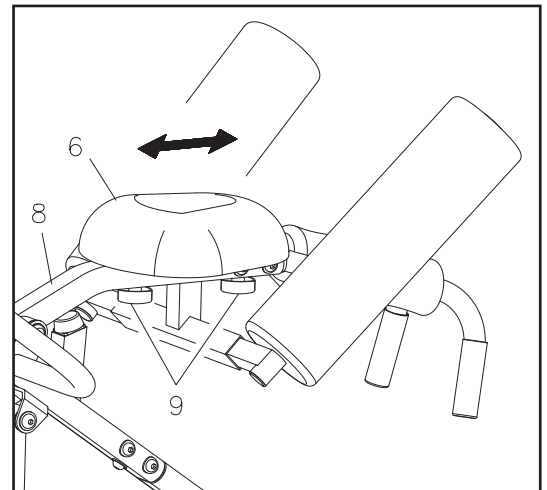

## OPERATIONAL INSTRUCTIONS

**CAUTION:** Keep both feet flat on the ground while stretching. Exercise within your limits. If you feel faint or dizzy, immediately discontinue use of this equipment.



**STEP ONE:** Adjust the height, rollers and waist belt as described on pages 12 and 13. Walk into the machine until the belt fits comfortably against your waist.



**STEP TWO:** Raise the two handles to bring the pad up against your chest. Your body should fit comfortably between the arm pads and the back of your arms should rest on the pads.



**STEP THREE:** Slowly lean into the machine. You should feel a gentle stretching in the spine and hamstrings. Go slowly and if needed make adjustments to the belt in order to find the position that allows you to comfortably stretch and decompress your spine. Maintain a comfortable stretching position for 2 or 3 minutes. Many people find additional relief by repeating this process a few times. Exhaling and breathing slowly while performing the movement will allow your muscles to relax so you can maximize the stretching and decompression effects.



## **STORAGE**

1. To store the **inLine® Traction Control System**, simply keep it in a clean dry place.
2. Two people are required to move the **inLine® Traction Control System**. One person is required to lift the back end of the **MAIN FRAME(14)** and another person is required to lift the **FRONT STABILIZER(2)**.

## **MAINTENANCE**

The safety and integrity designed into the **inLine® Traction Control System** can only be maintained when the **inLine® Traction Control System** is regularly examined for damage and wear. Special attention should be given to the following:

1. Verify that all nuts and bolts are present and properly tightened. Replace missing nuts and bolts. Tighten loose nuts and bolts.
2. Verify that the **CAUTION LABEL(38)** is in place and easy to read. Call Stamina Products immediately at **1-800-375-7520** for a replacement **CAUTION LABEL(38)** if it is missing or damaged.
3. It is the sole responsibility of the user/owner to ensure that regular maintenance is performed.
4. Worn or damaged components shall be replaced immediately or the **inLine® Traction Control System** removed from service until repair is made.
5. Only Stamina Products supplied components shall be used to maintain/repair the **inLine® Traction Control System**.
6. Keep your **inLine® Traction Control System** clean by wiping it off with an absorbent cloth after use.

# PRODUCT PARTS DRAWING

FRONT

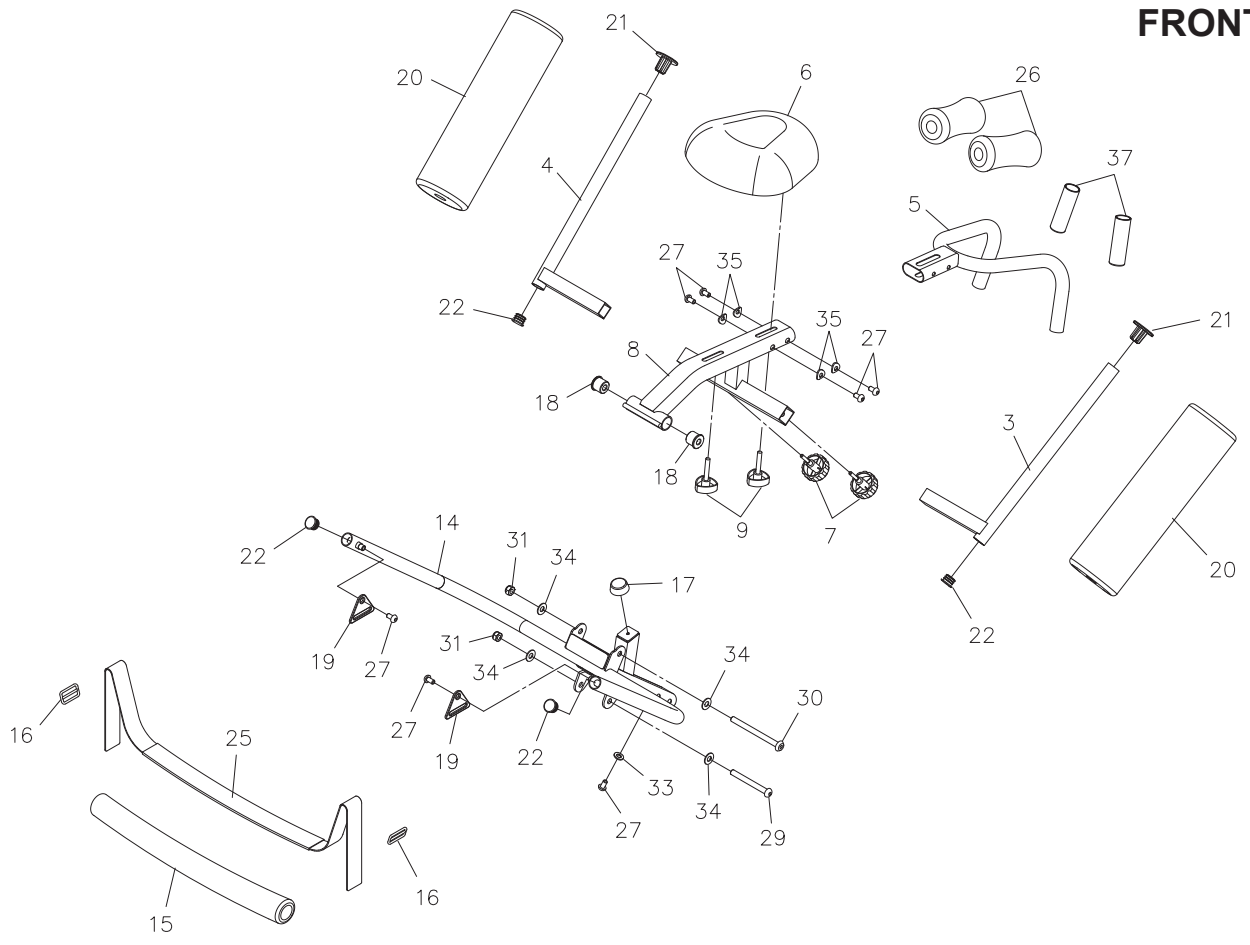

BACK

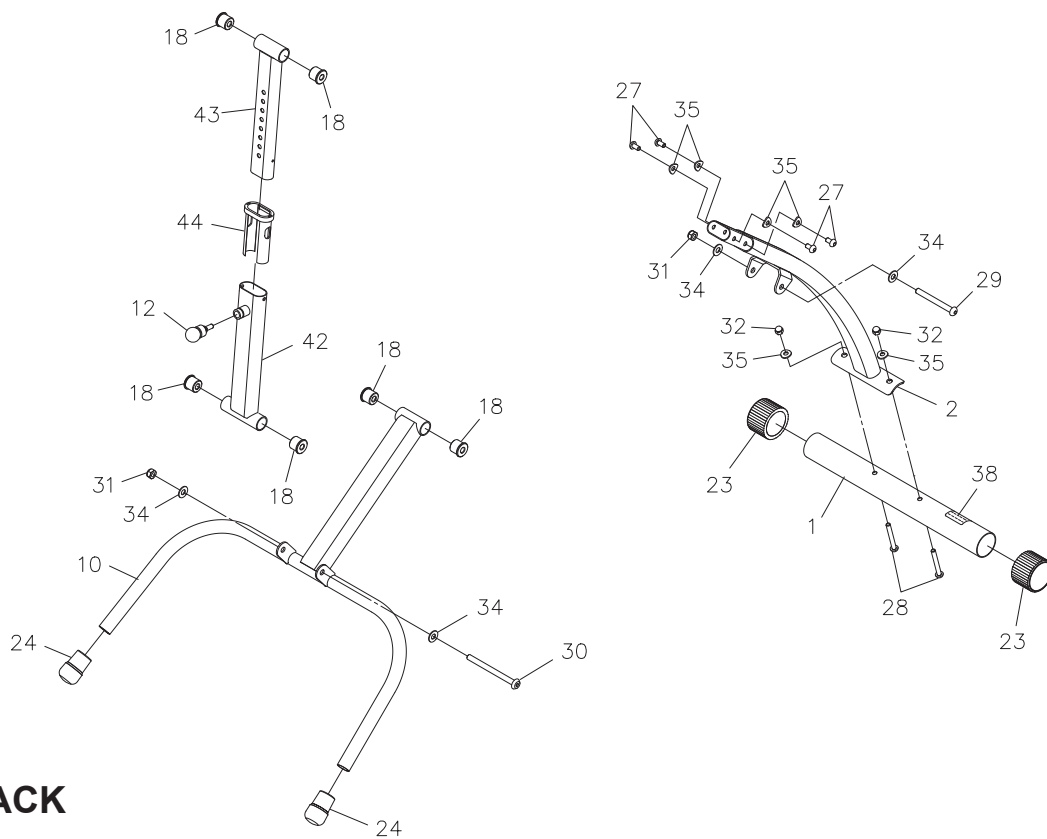

## PARTS LIST

PART#	PART NAME	QTY
1	Front Stabilizer	1
2	Front Support	1
3	Right Arm Pad Tube	1
4	Left Arm Pad Tube	1
5	Handlebar	1
6	Cushion	1
7	Adjustment Knob	2
8	Swing Arm	1
9	Locking Knob	2
10	Rear Support	1
12	Spring Pin	1
14	Main Frame	1
15	Foam Roller	1
16	Buckle	2
17	Bumper	1
18	Bushing	8
19	Triangle Hook	2
20	Arm Pad	2
21	Flange Plug (ø25.4mm)	2
22	Round Plug (ø25.4mm)	4
23	Endcap (ø50.8mm)	2
24	Dome Endcap (ø25.4mm)	2
25	Belt	1
26	Foam Pad	2
27	Bolt, Button Head (M8 x 1.25 x 15mm)	11
28	Bolt, Button Head (M8 x 1.25 x 60mm)	2
29	Bolt, Button Head (M10 x 1.5 x 95mm)	2
30	Bolt, Button Head (M10 x 1.5 x 125mm)	2
31	Nylock Nut (M10 x 1.5)	4
32	Acorn Nut (M8 x 1.25)	2
33	Washer (M8)	1
34	Washer (M10)	8
35	Arc Washer (M8)	10
37	Hand Grip	2
38	Caution Label	1
39	Allen Wrench (6mm)	1
40	Wrench	1
41	Manual	1
42	Outer Tube	1
43	Inner Tube	1
44	Oval Sleeve	1

## LIMITED WARRANTY

MODEL 20-4800A

### WARRANTY

Stamina Products, Inc. warrants that this product will be free from defects in materials and workmanship under normal use, service, proper assembly and proper operation for a period of 90 days on the parts and three years on the frame from the date of the original purchase from an authorized retailer. **THIS WARRANTY SHALL NOT APPLY TO ANY PRODUCT WHICH HAS BEEN SUBJECT TO COMMERCIAL USE, ABUSE, MISUSE, ALTERATION OF ANY TYPE OR CAUSE OR TO ANY DEFECT OR DAMAGE CAUSED BY IMPROPER ASSEMBLY, REPAIR, REPLACEMENT, SUBSTITUTION OR USE WITH PARTS OTHER THAN PARTS PROVIDED BY STAMINA PRODUCTS, INC.** Commercial use includes use of the product in athletic clubs, health clubs, spas, gymnasiums, exercise facilities, and other public or semipublic facilities whether or not the product's use is in furtherance of a profit making enterprise, and all other use which is not for personal, family, or household purposes.

To implement this limited warranty, send a written notice stating your name, date, and place of purchase and a brief description of the defect along with your receipt to **Stamina Products, Inc. P.O. Box 1071, Springfield Missouri, USA, 65801-1071**, or email us at **customerservice@staminaproducts.com**, or call us at **1-800-375-7520**. If the defect is covered under this limited warranty, you will be requested to return the product or part to us for free repair or replacement at our option. **NO ACTION FOR BREACH OF THIS LIMITED WARRANTY MAY BE COMMENCED MORE THAN ONE (1) YEAR AFTER THE DATE THE ALLEGED BREACH WAS OR SHOULD HAVE BEEN DISCOVERED. NO ACTION FOR BREACH OF ANY IMPLIED WARRANTY MAY BE COMMENCED MORE THAN ONE (1) YEAR AFTER DELIVERY OF THE PRODUCT TO THE PURCHASER.** This limited warranty is not transferable. **IF ANY PART OF THE PRODUCT IS NOT IN COMPLIANCE WITH THIS LIMITED WARRANTY OR ANY IMPLIED WARRANTY, THE REMEDY OF REPAIR OR REPLACEMENT IS THE EXCLUSIVE REMEDY AVAILABLE TO YOU.** In the event that the purchaser makes any claim under this limited warranty or any implied warranty, the Warrantor reserves the right to require the product to be returned for inspection, at the purchaser's expense, to the Warrantor's premises in Springfield, Missouri. Return of the enclosed warranty registration card is not required for warranty coverage, but is merely a way of establishing the date and place of purchase.

Stamina Products, Inc. **SHALL NOT BE LIABLE FOR THE LOSS OF USE OF ANY PRODUCT, LOSS OF TIME, INCONVENIENCE, COMMERCIAL LOSS OR ANY OTHER INDIRECT, CONSEQUENTIAL, SPECIAL OR INCIDENTAL DAMAGES DUE TO BREACH OF THE ABOVE WARRANTY OR ANY IMPLIED WARRANTY.**

This limited warranty is the only written or express warranty given by Stamina Products, Inc. This warranty gives you specific legal rights, and you may also have other legal rights which vary from state to state. **ANY OTHER RIGHT WHICH YOU MAY HAVE, INCLUDING ANY IMPLIED WARRANTY OR MERCHANTABILITY OR FITNESS FOR A PARTICULAR PURPOSE, IS LIMITED IN DURATION TO THE DURATION OF THIS WARRANTY.**

The laws in some jurisdictions restrict the rights of manufacturers and distributors of consumer goods to disclaim or limit implied warranties and consequential and incidental damages with respect thereto. If any such law is found to be applicable, the foregoing disclaimers and limitations of and on implied warranties and consequential and incidental damages with respect thereto shall be disregarded and shall be deemed not to have been made to the extent necessary to comply with such legal restriction.

## TO CONTACT CUSTOMER SERVICE

For your convenience, Stamina's customer service representatives can be reached by email at customerservice@staminaproducts.com or by phone at 1-800-375-7520 (in the U.S.). Our customer service representatives are available Monday through Thursday from 7:30 a.m. until 5:00 p.m., and Friday 8:00 a.m. until 3 p.m. Central Time.



**ONLINE  
CUSTOMER SERVICE**  
customerservice@staminaproducts.com  
www.staminaproducts.com



**TELEPHONE  
CUSTOMER SERVICE**  
Tel: 1 (800) 375-7520



**FAX  
CUSTOMER SERVICE**  
Fax: (417) 889-8064



**MAIL  
STAMINA PRODUCTS, INC.**  
ATTN: Customer Service  
P.O. Box 1071 Springfield, MO. 65801-1071

Would you like to receive email information or special offers from Stamina Products? Register at [contact.staminaproducts.com](http://contact.staminaproducts.com)

## TO REGISTER YOUR PRODUCT

To enact your warranty, please register your product by going to [register.staminaproducts.com](http://register.staminaproducts.com). Please have your product model number (printed on the cover of this owner's manual) and the serial number (printed on the black and white sticker on your product) ready.

If you don't have internet access, you can call customer service at 1-800-375-7520, or fill out and mail the product registration form below to Stamina Products, Inc.; P.O. Box 1071; Springfield, MO 65801-1071.

<b>PRODUCT REGISTRATION FORM</b>	<b>Stamina Products, Inc.</b> P.O. Box 1071 Springfield, MO 65801-1071
Model Number: .....	Serial Number: .....
Product Name: .....	
Place Purchased: .....	
Date of Purchase: .....	Purchase Price: .....
First Name: .....	Last Name: .....
City: .....	State: ..... Zip Code: .....
Email Address: .....	Phone #: (     ) .....
Would you like to receive email information or special offers from Stamina Products?* <input type="checkbox"/> Yes <input type="checkbox"/> No *If yes, be sure your email address is included above.	



Detach and Mail or Fax the Form Above



## TO ORDER PARTS

If there are missing or damaged parts, you can go to [parts.staminaproducts.com](http://parts.staminaproducts.com) and order those parts. If you have questions, please contact customer service. Do not return the product. To order parts by mail, fill out the sheet below and fax it to 417-889-8064. The part will be mailed to your address.



Detach and Mail or Fax the Form Below



<b>PARTS ORDER FORM</b>	<b>Stamina Products, Inc.</b> P.O. Box 1071 Springfield, MO 65801-1071	
Mr./Ms: .....		
Address: ..... Apt. #: .....		
City: ..... State: ..... Zip Code: .....		
<b>IMPORTANT : We must have your phone number to process the order!</b>		
Phone #: (     ) ..... Work Phone #: (     ) .....		
Date of Purchase: .....		
Model #: .....		
Purchased From: .....		
<b>IMPORTANT : Before filling out the form below make sure you have the correct information. Refer to the parts list to make sure you're ordering the right parts!</b>		
PART #	DESCRIPTION	QUANTITY
EXAMPLE: 1	Rear Unit Assembly	1