

Duro
NEXT GENERATION

Max
POWER SYSTEMS

TM

Gasoline Powered Generator

Owner's Manual

XP4400



XP4400E

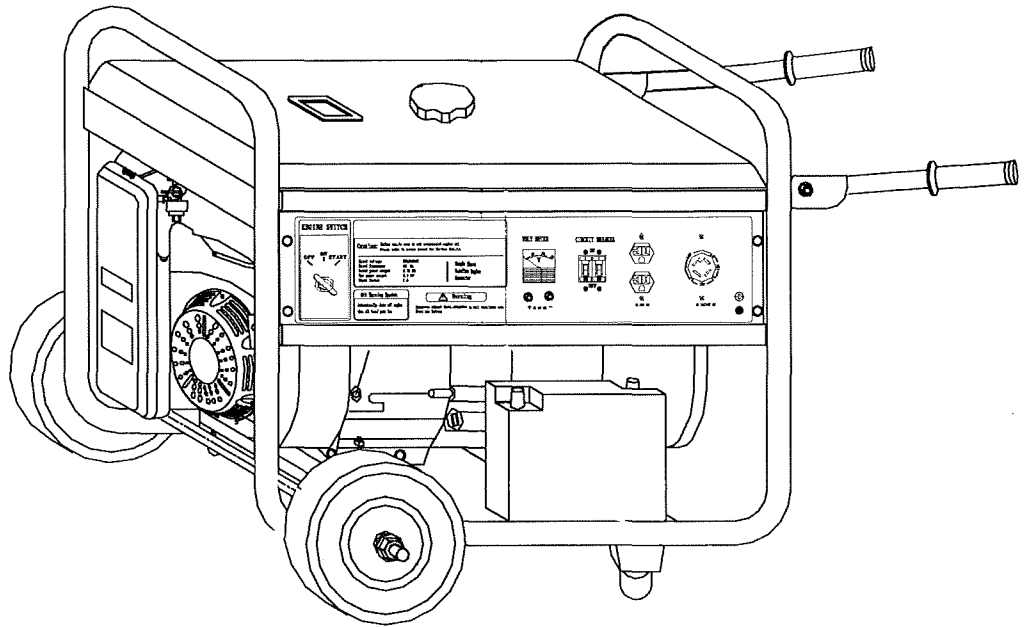

Max Tool Customer Service

customer_service@maxtool.com

or call 1-800-629-3325 (option 3) Monday -Thursday 6am to 7pm, Friday - Saturday 6am to 3pm. PST

Product Support (Product: information, application, service info & warranty questions)

support@maxtool.com

or call 1-800-629-3325 (option 3) Monday -Thursday 6am to 7pm, Friday - Saturday 6am to 3pm. PST

This manual provides information regarding the operation and maintenance of these products.

We have made every effort to ensure the accuracy of the information in this manual.

We reserve the right to change this product at any time without prior notice.

FEATURES

- ***Durable 6.5 Hp, Air Cooled Overhead Valve Engine.***
- ***Heavy Duty Steel Frame with Four Point Fully Isolated Motor Mounts for Smooth and Quiet Operation.***
- ***Wheel and Handle Kit for Easy Transporting.***
- ***Full Power Panel with Engine Shutoff Switch, Volt Meter, Circuit Breaker and Power Outlets.***
- ***(2) Fully Protected 120V Outlets & (1) 120V/240V Twist-Lock Outlet.***
- ***8 Hour Run Time.***
- ***All Steel 4.0 Gal. Fuel Tank with EZ-Read Gauge.***
- ***Low Oil Shut-Off Protects Engine.***
- ***Super Quiet Muffler Reduces Engine Noise.***
- ***Meets EPA and CARB Emission Standards.***

Notice Regarding Emissions

Engines that are certified to comply with California and U.S. EPA emission regulations for SORE (Small Off Road Equipment), are certified to operate on regular unleaded gasoline, and may include the following emission control systems: (EM) Engine Modifications and (TWC) Three-Way Catalyst (if so equipped).

TABLE OF CONTENTS

GENERAL SAFETY PROCEDURES	1
PACKAGE CONTENTS.....	4
GENERATOR COMPONENTS	5
PREPARING THE GENERATOR FOR USE	6
Using the Generator for the First Time.....	6
Step 1 – Add Oil.....	6
Step 2 – Add Gasoline	7
Step 3 – Ground the Generator	8
Subsequent Use of the Generator	8
Step 1 – Check the Oil	8
Step 2 – Check the Gas Level	8
Step 3 – Ground the Generator	9
STARTING THE GENERATOR	9
USING THE GENERATOR	10
AC Usage	10
DC Usage.....	13
STOPPING THE GENERATOR	14
MAINTENANCE / CARE	14
Cleaning the Generator	15
Checking the Oil	15
Changing / Adding Oil.....	15
Air Cleaner Maintenance	17
Fuel Filter Cup Cleaning	17
Spark Plug Maintenance.....	17
Emptying the Gas Tank	18
STORAGE / TRANSPORT PROCEDURE	18
SPECIFICATIONS.....	19
TROUBLESHOOTING	19
GENERATOR ASSEMBLY AND MOUNTING	20
CHANGE THE CARBON-BRUSH.....	21
CHANGE THE AVR.....	22
WIRING DIAGRAM	23
EXPLODED VIEW AND PARTS LIST	25

GENERAL SAFETY PROCEDURES

Please familiarize yourself with the following safety symbols and words:

The safety alert symbol  is used with one of the safety words (**DANGER**, **CAUTION**, or **WARNING**) to alert you to hazards. Please pay attention to these hazard notices both in this manual and on the generator.

DANGER: Indicates a hazard that will result in serious injury or death if instructions are not followed.

WARNING: Indicates a strong possibility of causing serious injury or death if instructions are not followed.

CAUTION: Indicates a possibility of personal injury or equipment damage if instructions are not followed.

 **DANGER:** This generator produces poisonous carbon monoxide gas when running. This gas is both odorless and colorless. Even if you do not see or smell gas, carbon monoxide may still be present. Breathing this poison can lead to headaches, dizziness, drowsiness, and eventually death.

- Use outdoors **ONLY** in non-confined areas.
- Keep several feet of clearance on all sides to allow proper ventilation of the generator.

 **WARNING:** The exhaust from this product contains chemicals known to the State of California to cause cancer, birth defects, or other reproductive harm.

 **WARNING:** This generator may emit highly flammable and explosive gasoline vapors, which can cause severe burns or even death. A nearby open flame can lead to explosion even if not directly in contact with gas.

- Do not operate near open flame.
- Do not smoke near generator.
- Always operate on a firm, level surface.
- Always turn generator off before refueling. Allow generator to cool for at least 2 minutes before removing fuel cap. Loosen cap slowly to relieve pressure in tank.
- Do not overfill gas tank. Gas may expand during operation. Do not fill to the top of the tank.
- Always check for spilled gas before operating.
- Empty gasoline tank before storing or transporting the generator.
- Before transporting, turn fuel valve to off and disconnect spark plug.

⚠ WARNING: This generator produces powerful voltage, which can result in electrocution.

- ALWAYS ground the generator before using it (see the "Grounding the Generator" portion of the "PREPARING THE GENERATOR FOR USE" section).
- Generator should only be plugged into electrical devices, either directly or with an extension cord. NEVER connect to a building electrical system without a qualified electrician. Such connections must comply with local electrical laws and codes. Failure to comply can create a backflow of power, which may result in serious injury or death to utility workers.
- Use a ground fault circuit interrupter (GFCI) in highly conductive areas such as metal decking or steel work. GFCIS are available in-line with some extension cords.
- Do not use in rainy or wet conditions.
- Do not touch bare wires or receptacles (outlets).
- Do not allow children or non-qualified persons to operate.

⚠ WARNING: This generator produces heat when running. Temperatures near exhaust can exceed 150°F (65°C).

- Do not touch hot surfaces. Pay attention to warning labels on the generator denoting hot parts of the machine.
- Allow generator to cool several minutes after use before touching engine or areas which heat during use.

CAUTION: Misuse of this generator can damage it or shorten its life.

- Use generator only for its intended purposes.
- Operate only on dry, level surfaces.
- Allow generator to run for several minutes before connecting electrical devices.
- Shut off and disconnect any malfunctioning devices from generator.
- Do not exceed the Wattage capacity of the generator by plugging in more electrical devices than the unit can handle (see "PRECAUTIONS-OVERLOADING THE GENERATOR").
- Do not turn on electrical devices until after they are connected to the generator.
- Turn off all connected electrical devices before stopping the generator.

In addition to the above safety notices, please familiarize your self with the safety and hazard markings on the generator.

CAUTION! POISONOUS GAS

Generator exhaust contains toxic carbon monoxide gas. NEVER operate indoors or in poorly ventilated areas.

WARNING! RISK OF EXPLOSION

- Stop generator before refueling.
- Check for spilled fuel.
- Do not operate near open flame.

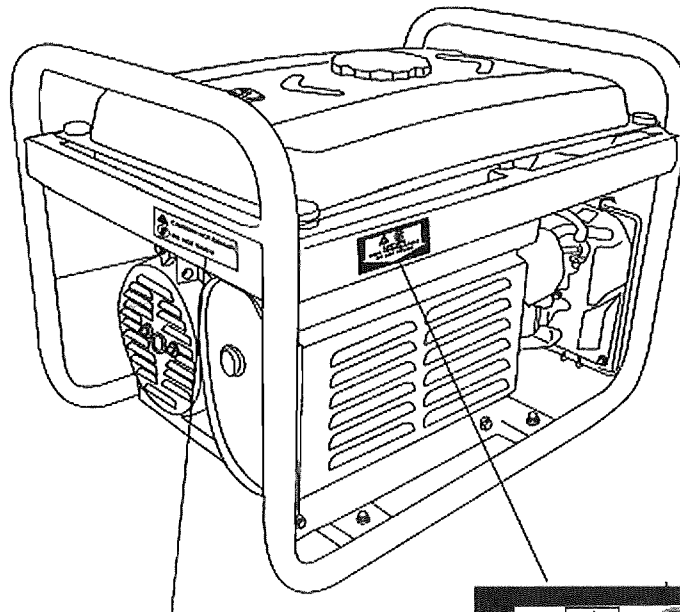
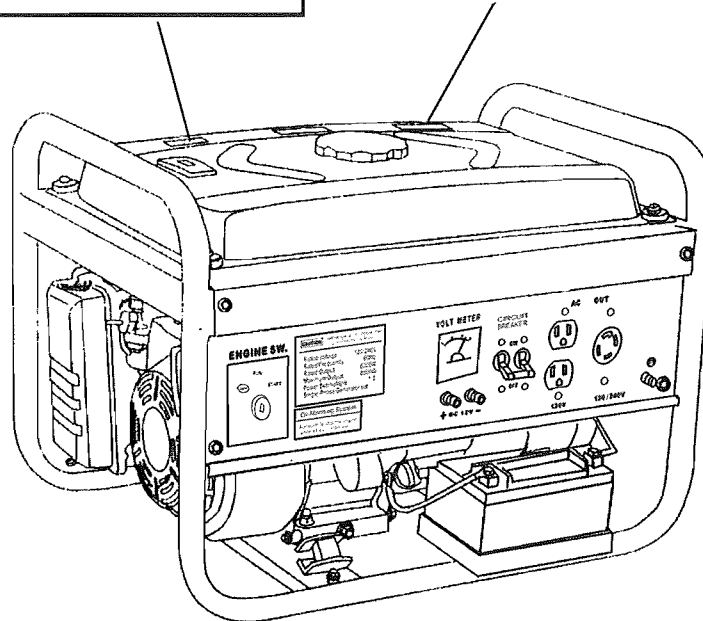

CAUTION! HOT EXHAUST

DO NOT TOUCH

↓

CAUTION! HIGH TEMPERATURE

DO NOT TOUCH

PACKAGE CONTENTS

Your generator comes with the items listed below. Please check to see that all of the following items may be included with your generator, depending on your generator model.



Screw driver

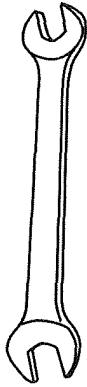

Spanner

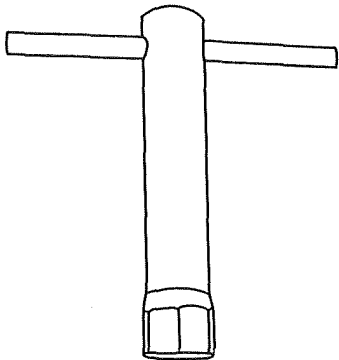

Spark plug wrench

GENERATOR COMPONENTS

Please familiarize yourself with the locations and functions of the various components and controls of your generator.

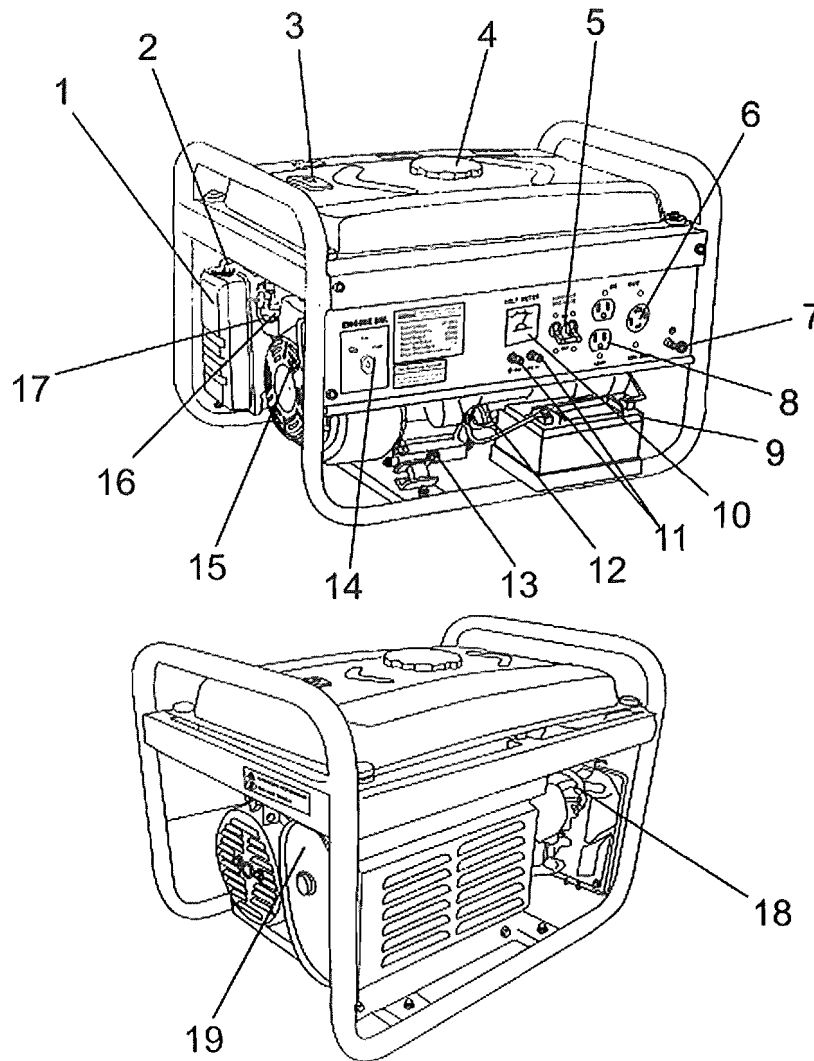

(1) Air cleaner- a removable, cleanable, sponge-like element that limits the amount of dirt pulled into the engine.

(2) Choke lever- Adjusts the amount of air let into the engine.

(3) Fuel Gauge- Indicates the amount of fuel in the tank.

(4) Fuel Cap- Access to the fuel tank for adding fuel.

(5) Circuit Breaker- Reset switch that protects the generator from electrical overload.

(6) 120/ 240 Volt AC Receptacle- Use to connect electrical devices that run 120 and/or 240 Volt, 60Hz, single phase, AC current (NEMA L14-30).

(7) Ground Terminal- Connect grounding wires here to properly ground unit.

(8) 120 Volt AC Receptacle- Use to connect electrical devices that run 120 Volt, 60 Hz, single phase, AC current (2× duplex GFCI).

(9) 12V DC of batteries.

(10) Volt Meter- Provides reading of voltage output.

- (11) **I2V DC Receptacle**- Use for charging 12 Volt automotive-type batteries only.
- (12) **Oil Filler Cap**- Use to Add oil or checking the oil.
- (13) **Oil Fill and Dipstick**- Location for checking and filling engine oil.
- (14) **Engine Switch**- Used to start/stop engine.
- (15) **Recoil Starter**- Pull-cord for starting engine.
- (16) **Fuel Filter Cup**- Traps dirt and water from fuel before it enters the engine.
- (17) **Fuel valve**- Allows fuel to enter engine.
- (18) **Spark plug**- Provides proper engine ignition.
- (19) **Muffler**- Reduces engine noise.

PREPARING THE GENERATOR FOR USE

Using the Generator for the First Time

If you are using the generator for the first time, there are a few steps you must take to prepare it for operation.

Step 1- Add oil

The generator requires engine oil to operate properly. The generator, when new from the package, contains no oil in the crankcase. You must add the proper amount of oil before operating the generator for the first time. This amount, which is equal to the oil capacity of the engine crankcase, can be found on the chart in *figure 1*. When filling the engine with oil in the future, please refer to this chart.

Model number	XP4400	XP4400E
Engine oil capacity	20 fluid oz.	

Figure 1- Generator Oil Capacity

CAUTION:

- **Do not apply engine oil with additives or 2-stroke gasoline engine oil**, as they haven't enough lubrication, which may shorten the engine's service life.
- **Engine oil recommended: SAE 10W-30.** As viscosity varies with regions and temperatures, so the lubricant has to be selected in accordance with our recommendation.

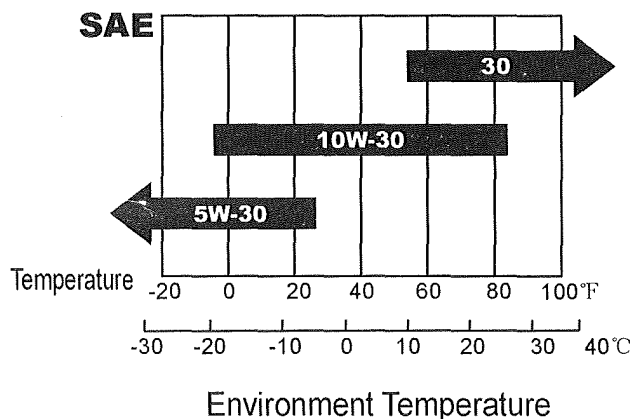

To add oil, follow these steps:

1. Make sure the generator is on a level surface.
2. Unscrew the oil filler/dipstick cap from the engine as shown in *figure 2*.
3. Using a funnel, add the appropriate amount of oil, as found in *figure 1*, into the crankcase. You will know the crankcase is full when the oil level has reached the lower lip of the opening you have just poured the oil into (see *figure 3*).
4. Replace oil filler cap.

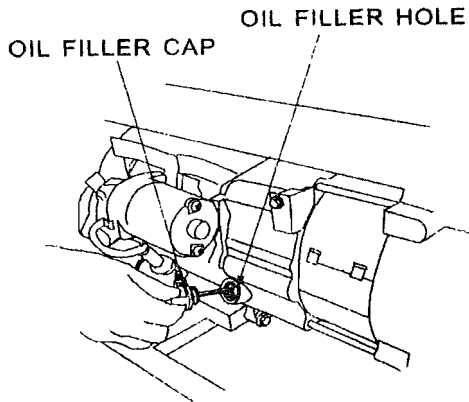

Figure 2- Unscrewing the oil cap



Figure 3 - Adding oil

Step 2- Add Gasoline

⚠ WARNING: Gasoline and gas fumes are highly flammable.

- Do not fill tank near an open flame.
- Do not overfill. Always check for fuel spills.

To ensure that the generator runs smoothly use only FRESH, UNLEADED GAS WITH AN OCTANE RATING OF 87 OR HIGHER. To add gasoline:

1. Make sure the generator is on a level surface.
2. Unscrew gas cap and set aside (NOTE: the gas cap may be tight and hard to unscrew).
3. Slowly add unleaded gasoline to the fuel tank. Be careful not to overfill. Please refer to the chart in *figure 4* to find the gas capacity of your generator model. The fuel gauge on the top of the generator indicates how much gasoline is in the generator gas tank. NOTE: Gas can expand. Do not fill the gas tank to the very top.
4. Replace fuel cap and wipe up any spilled gasoline with a dry cloth.

IMPORTANT:

- Never use an oil/gasoline mixture.
- Never use old gas.
- Avoid getting dirt or water in the fuel tank.
- Gas can age in the tank and make it hard to start up the generator in the future.
- Never store generator for extended periods of time with fuel in the tank.

Model number	XP4400	XP4400E
Gas tank capacity	15L(3.96 us. gallons)	

Figure 4 - Gas Tank Capacity

Step 3- Ground the Generator

⚠ WARNING: Failure to properly ground the generator can result in electrocution.

Ground the generator by tightening the grounding nut against a grounding wire (see *figure 5*). A generally acceptable grounding wire is a No. 12 AWG (American Wire Gauge) stranded copper wire. This grounding wire should be connected at the other end to a copper or brass-grounding rod that is driven into the end. Grounding codes can vary by location. Please contact a local electrician to check the grounding regulations for your area.

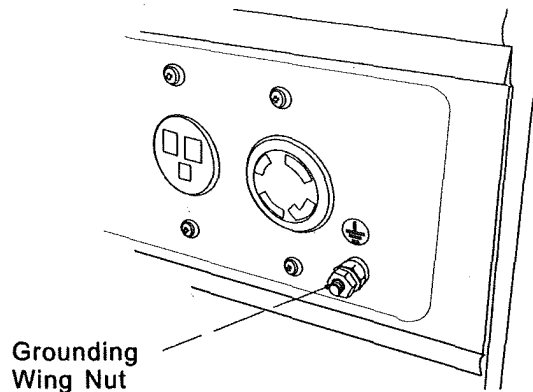

Figure 5 – Attaching the Grounding Wire to the Generator

Subsequent Use of the Generator

If this is not your first time using the generator there are still steps you should take to prepare it for operation.

IMPORTANT: At this point you should be familiar with the procedures described in the first portion of this section entitled "*Using the Generator for the First Time.*" If you have not yet read this section, go back and read it now.

Step 1- Check the oil

The generator is equipped with an automatic shutoff to protect it from damage due to low oil. Nonetheless, you should check the oil level of the engine before each use to ensure that the engine crankcase has a sufficient amount. To check the oil level:

1. Make sure the generator is on a level surface.
2. Unscrew the oil filler/dipstick cap.
3. With a dry cloth, wipe the oil off of the stick on the inside of the cap.
4. Insert the dipstick as if you were replacing the cap and then remove again. There should now be oil on the stick. If there is no oil on the stick, or oil only at the very end of the stick, you should add oil until the engine crankcase is filled (see "*Adding Oil*" portion of the "*Maintenance*" section).
5. Be sure to replace cap when finished checking oil.

NOTE: The oil capacity for your generator can be found in the "*Specifications*" section of this manual.

Step 2 - Check the Gas Level

Before starting the generator, check to see that there is sufficient gasoline in the gas tank. The fuel gauge on top of the generator will indicate the gas level in the tank. Add gas if necessary according to the steps in the "*Adding Gasoline*" portion of the "*Maintenance*" section.

⚠ WARNING: Gasoline and gasoline fumes are highly flammable.

- Do not fill tank near an open flame.
- Always allow engine to cool for several minutes before refueling.
- Do not overfill (check the "Specifications" section for the tank capacity of your generator). Always check for fuel spills.

IMPORTANT:

- Use only UNLEADED gasoline with an octane rating of 87 or higher.
- Do not use old gas.
- Never use an oil/gasoline mixture.
- Avoid getting dirt or water in the fuel tank.
- Never store generator for extended periods of time with fuel in the tank.

Step 3- Ground the Generator

⚠ WARNING: Failure to properly ground the generator can result in electrocution.

Ground the generator by tightening the grounding nut against a grounding wire (see J figure 5). A generally acceptable grounding wire is a No. 12 AWG (American Wire Gauge) stranded copper wire. This grounding wire should be connected at the other end to a copper or brass-grounding rod that is driven into the earth.

Grounding codes can vary by location. Please contact a local electrician to check the grounding regulations for your area.

STARTING THE GENERATOR

⚠ CAUTION: Disconnect all electrical loads from the generator before attempting to start.

To start your generator, perform the following steps:

1. Make sure no electrical devices are connected to the generator. Such devices can make it difficult for the engine to start.
2. Check that the generator is properly grounded (see page 13, "*Ground the Generator*").
3. Turn the fuel valve to the "ON" position (see *figure 6*).
4. Move the choke lever to the "CLOSED" position (see *figure 7*).
5. Set the engine switch to the "ON" position.
6. Pull on the recoil starter handle slowly until a slight resistance is felt (see *figure 8*). Then pull quickly to start the engine. Return cord gently into the machine. Never allow the cord to snap back.
7. If engine fails to start, repeat step 4. NOTE: After repeated attempts to start the engine, please consult the troubleshooting guide before attempting again.
8. Once the engine has started and run for about a minute, move the choke lever about half way towards the "OPEN" position. Wait another 30 seconds and then move the choke lever all the way to the "OPEN" position.
9. Allow the generator to run for several minutes before attempting to connect any electrical devices.

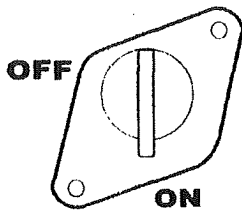

Figure 6- Fuel Valve in the “on” position

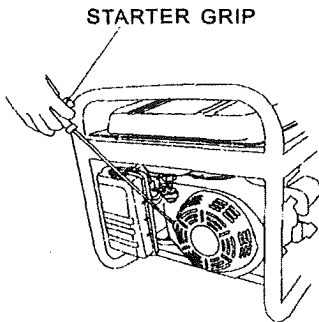

Figure 8- Pulling the start cord

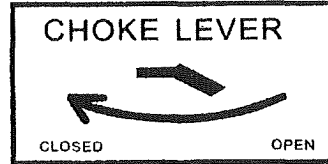

Figure 7- Choke in the “closed” position (refer to choke location)

USING THE GENERATOR

Once you have allowed the engine to run for several minutes, you may connect electrical devices to the generator.

AC Usage

You may connect electrical devices running on AC current according to their wattage requirements. The chart in figure 9 shows the rated and surge wattage of your generator according to its model number.

The *rated wattage* corresponds to the maximum wattage the generator can output on a continuous basis.

The *surge wattage* corresponds to the maximum amount of power the generator can output for a short period of time. Many electrical devices such as refrigerators require short bursts of extra power, in addition the rated wattage listed by the device, to stop and start their motors. The surge wattage ability of the generator covers this extra power requirement.

Model Number	Rated (Running) Wattage	Surge Wattage
XP4400	3500	4400
XP4400E	3500	4400

Figure 9-generator wattage by model number

The total running wattage requirement of the electrical devices connected to the generator should not exceed the rated wattage of the generator itself. To calculate the total wattage requirement of the electrical devices you wish to connect, find the rated (or running) wattage of each device. This number should be listed somewhere on the device or in its instruction manual. If you cannot find this wattage, you may calculate it by multiplying the Voltage requirement by the Amperage drawn:

$$\text{Watts} = \text{Volts} \times \text{Amperes}$$

If these specifications are not available you may estimate the Watts required by your device by using the chart in *figure 10*.

Tool or Appliance	Rated (Running) Watts	Additional Surge Watts
Electric water heater (40 gal)	4000	0
Hot plate	2500	0
Saw-radial arm	2000	2000
Electric stove	1500	0
Saw-circular	1500	1500
Air compressor (1HP)	1500	3000
Window air conditioner	1200	1800
Saw-miter	1200	1200
Microwave	1000	0
Well water pump	1000	1000
Reciprocating saw	960	1040
Sump pump	800	1200
Refrigerator freezer	800	1200
Furnace blower	800	1300
Computer	800	0
Electric drill	600	900
Television	500	0
Deep freezer	500	500
Garage door opener	480	0
Stereo	400	0
Box fan	300	600
Clock radio	300	0
Security system	180	0
DVD player/VCD	100	0
Common light bulb	75	0

Figure 10- Estimated wattage requirements of common electrical devices.

Once you have found the rated wattage requirement of each electrical device, add these numbers to find the total rated wattage you wish to draw from the generator. If this number exceeds the rated wattage of the generator, **DO NOT** connect all these devices, Select a combination of electrical devices, which has a total rated wattage lower than or equal to the rated wattage of the generator.

CAUTION - The generator can run at its surge wattage capacity for only a short time. Connect electrical devices requiring a rated (running) wattage equal to or less than the rated wattage of the generator. Never connect devices requiring a rated wattage equal to the surge wattage of the generator.

NOTE: The above wattage figures are estimates. Try to check the wattage listed on your electrical device before consulting this chart.

Once you have determined what electrical devices you will be powering with the generator, connect these devices according to the following procedure:

1. Plug in each electrical device with the device turned off.
 - a. **NOTE:** Be sure to attach appliances to the correct receptacle (outlet). Connect standard 120 Volt, single phase, 60 Hz loads only to the 120 Volt receptacle.
 - b. Connect 120/240 Volt, single phase, 60Hz loads with NEMA L14-30 plug **only** to the 120/240 Volt receptacle See *Figure 11* for a depiction of each of these receptacles.
2. Switch the circuit breaker to the "ON" position.
3. Turn on the connected electrical devices in the order of the amount of power they require beginning with the device with the highest rated Wattage requirement.

CAUTION: Do not connect 50Hz or 3-phase loads to the generator.

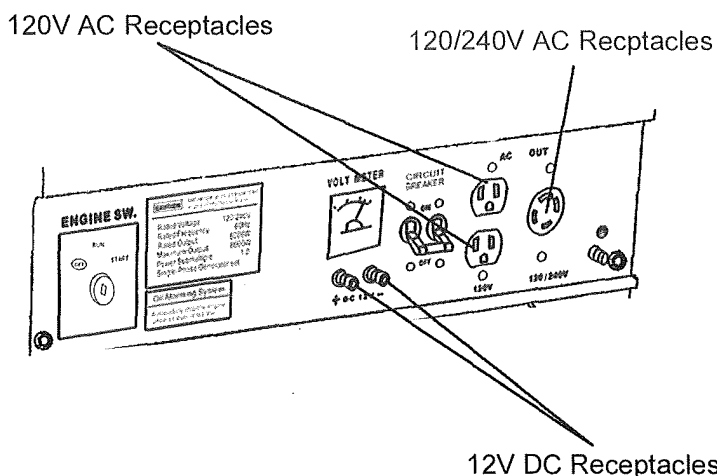

Figure 11- Receptacles available on the generator

VOLTAGE SELECTOR SWITCH (XP4400/XP4400E)

The voltage selector switches the main power carrying windings of the generator to produce "120V ONLY" or "120/240V". If a 240V appliance is connected to the 4-prong receptacle, the switch must be in the "120/240V" position. If only a 120V appliance is being connected to any of the 120V 3-prong receptacles, select the "120V ONLY" position.

- 120/240V: The 120V and 120/240V receptacles can be used simultaneously.
- 120V: ONLY the 120V receptacles can be used. Do not use the 120/240V receptacle in this position. Rated power will be available at the 120V twist lock receptacle.

WARNING:

Change the Voltage Selector Switch after turning the AC circuit breaker to OFF. The generator may be damaged.

SOME NOTES ABOUT POWER CORDS

Long or thin cords can drain the power provided to an electrical device by the generator. When using such cords, allow for a slightly higher rated wattage requirement by the electrical device. See *Figure 12* for recommended cords based on the power requirement of the electrical device.

Device Requirements			Max. Cord Length (ft) by Wire Gauge				
Amps	Watts (120V)	Watts (240V)	#8 wire	#10 wire	#12 wire	#14 wire	#16 wire
2.5	300	600	NR	1000	600	375	250
5	600	1200	NR	500	300	200	125
7.5	900	1800	NR	350	200	125	100
10	1200	2400	NR	250	150	100	50
15	1800	3600	NR	150	100	65	NR
20	2400	4800	175	125	75	50	NR
25	3000	6000	150	100	60	NR	NR
30	3600	7200	125	65	NR	NR	NR
40	4800	9600	90	NR	NR	NR	NR

*NR= not recommended

Figure 12-Maximum Extension Cord Lengths by Power Requirement

DC Usage

CAUTION: The DC receptacle is for recharging 12 Volt automotive-type batteries only. Do not connect any other device to this receptacle.

CAUTION: Use the generator only to recharge 12 Volt batteries. Never try to jumpstart a car with your generator.

To connect 12 Volt batteries to the DC receptacle:

1. Connect one charging wire to the positive terminal on the battery and the other charging wire to the negative terminal.
2. Connect the free end of the positive wire to the positive receptacle (outlet) on the generator.
3. Start the generator.
4. Carefully connect the free end of the negative wire to the negative receptacle on the generator.
5. When disconnecting, always disconnect the wires from the generator first to avoid a spark.

⚠ DANGER: Storage batteries emit highly explosive hydrogen gas when charged. Batteries also contain acid, which can cause severe chemical burns.

- Do not allow open flames or cigarettes nearby for several minutes after charging a battery.
- Always wear protective goggles and rubber gloves when charging a battery.
 - ☆ If battery acid gets on your skin, flush with water.
 - ☆ If battery acid gets in your eyes, flush with water and call a physician immediately.
 - ☆ If battery acid is swallowed, drink large quantities of milk and call a Physician immediately.

If the generator you buy is electric start one, once beginning to work, it will charge the battery on the generator automatically. At this time, you can see the indication light is shining, after the battery is full, the light will be extinct.

STOPPING THE GENERATOR

To stop the generator:

1. Turn off, then unplug all connected electrical devices.
2. Switch the circuit breaker to the "OFF" position.
3. Allow the generator to run for several more minutes with no electrical devices connected. This helps stabilize the temperature of the generator.
4. Set the engine switch to the "OFF" position.
5. Turn the fuel valve to the "OFF" position.

⚠ WARNING: Allow the generator to cool for several minutes before touching areas that become hot during use.

CAUTION: Allowing gas to sit in the generator tank for long periods of time without use can make it difficult to start the generator in the future. Never store generator for extended periods of time with fuel in the tank.

MAINTENANCE /CARE

Proper routine maintenance of your generator will help prolong the life of your machine. Please perform maintenance checks and operations according the schedule in *figure 13*.

CAUTION: Never perform maintenance operations while the generator is running.

Recommended Maintenance schedule

		Each use	Every month or 20 hrs	Every 3 months or 50 hrs	Every 6 months or 100 hrs	Every year or 300 hrs
Engine oil	Check level	×				
	Replace		×			
Air cleaner	Check	×				
	Clean			×		
Fuel filter cup	Clean				×	
Spark plug	Check/clean				×	
Gas tank	Check gas level	×				
	Clean		×			×

Figure 13- Recommended maintenance schedule

Cleaning the Generator

Always try to use your generator in a cool dry place. However, in the event your generator becomes dirty you may clean the exterior with one or more of the following:

- A damp cloth
- A soft brush

- A vacuum
- Pressurized air

Never clean your generator with a bucket of water or a hose. Water can get inside the working parts of the generator and cause a short circuit or corrosion.

Checking the Oil

The generator is equipped with an automatic shutoff to protect it from running on low oil. Nonetheless, you should check the oil level of the generator before each use to ensure that the generator crankcase has a sufficient amount. To check the oil level:

1. Make sure the generator is on a level surface.
2. Unscrew the oil filler/dipstick cap (see *figure 14*).
3. With a dry cloth, wipe the oil off of the stick on the inside of the cap.
4. Insert the dipstick as if you were replacing the cap and then remove again. There should now be oil on the stick. If there is no oil on the stick, or oil only at the very end of the stick, you should add oil until the engine crankcase is filled. See "*Changing/ Adding Oil*" in this section.
5. Be sure to replace cap when finished checking oil.

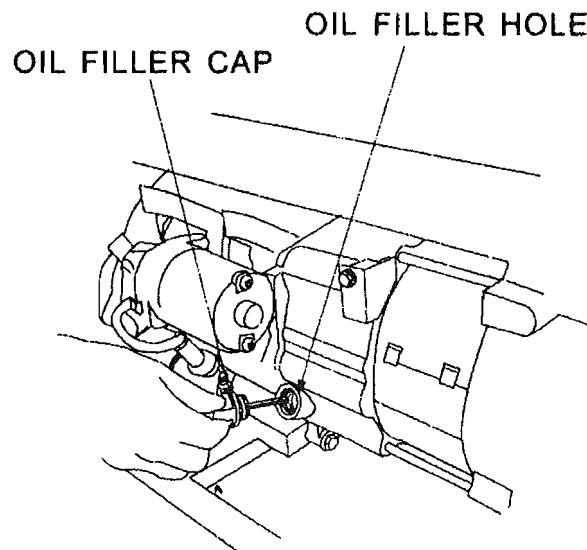

Figure 14- Checking the Oil

Changing/ Adding Oil

You should check the oil level of your generator according to the maintenance schedule in *figure 13*. When the oil level is low you will need to add oil until the level is sufficient to run the generator.

The oil capacity of your generator engine is listed in *figure 15*

Model number	XP4400	XP4400E
Engine oil capacity	20 fluid oz.	

Figure 15- Engine Oil Capacity.

It is only necessary to drain the oil from the crankcase if it has become contaminated with water or dirt. In this case, you can drain the oil from the generator according to the following steps:

1. Place a bucket underneath the generator to catch oil as it drains.
 2. Using a 10 mm hex wrench, unscrew the oil drain plug, which is located on the crankcase underneath the oil filler/dipstick cap (see *figure 16*). Allow all the oil to drain from the generator.
 3. Replace the oil drain plug and tighten with a 10 mm hex wrench.
- To add oil to the crankcase, follow these steps:
1. Make sure the generator is on a level surface.
 2. Unscrew the oil filler/dipstick cap from the engine as shown in *figure 14* above.
 3. Using a funnel, add high detergent motor oil to the crankcase. We recommend SAE 10W30 motor oil for general use. When full, the oil level should come close in the top of the oil fill opening (see *figure 17*).

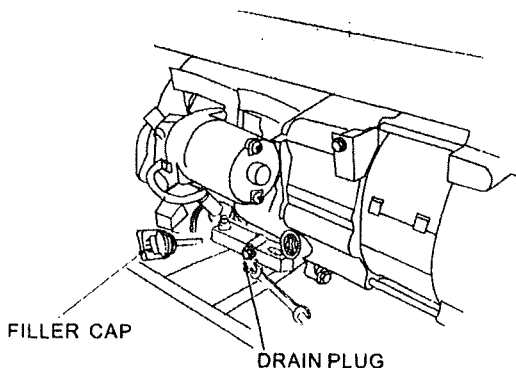

Figure 16- Draining oil



Figure 17- Adding oil

NOTE: Never dispose of used motor oil in the trash or down a drain. Please call your local recycling center or auto garage to arrange oil disposal.

Air Cleaner Maintenance

Routine maintenance of the air cleaner helps maintain proper airflow to the carburetor. Occasionally check that the air cleaner is free of excessive dirt.

1. Unhinge the clasps at the top and bottom of the air cleaner cover (see *figure 18*).
2. Remove the sponge-like elements from the casing.
3. Wipe the dirt from inside the empty air cleaner casing
4. Wash the sponge-like elements in household detergent and warm water. Allow to dry.
5. Soak the dry elements in engine oil. Squeeze out any excess oil.
6. Replace the sponge-like elements in the air cleaner casing and replace the cover.

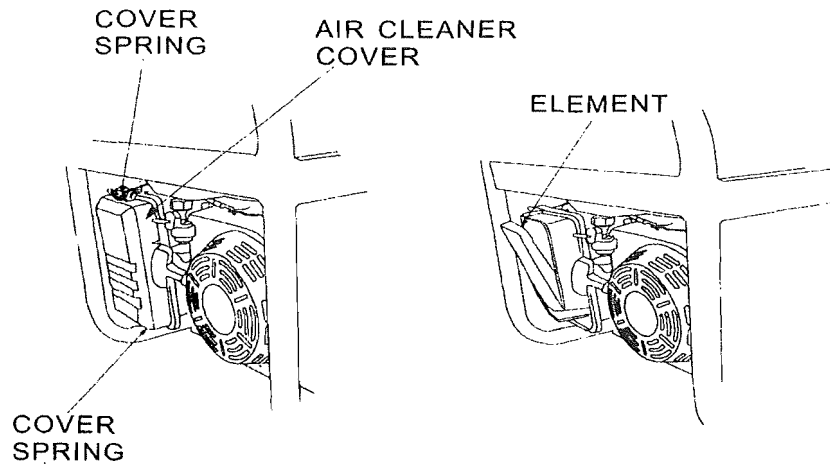

Figure 18- Removing the air cleaner casing.

Fuel Filter Cup Cleaning

The fuel filter cup is a small well underneath the fuel valve. It helps to trap dirt and water that may be in your fuel tank before it can enter the engine. To clean the fuel filter cup:

1. Turn the fuel valve to the "OFF" position.
2. Unscrew the fuel filter cup from the fuel valve using a wrench. Turn the valve toward you to unscrew (see figure 19).
3. Clean the cup of all sediment. Using a rag or brush.
4. Reinstall the fuel filter cup.

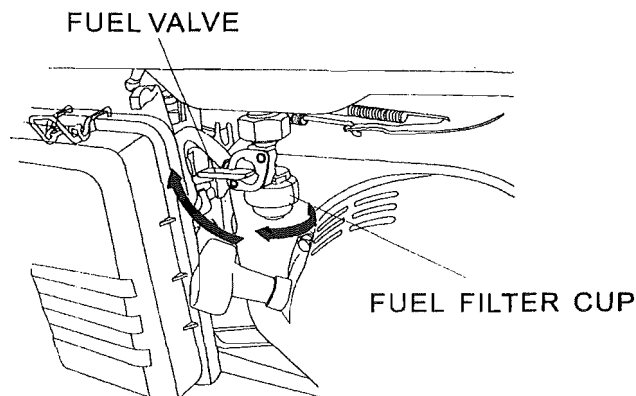

Figure 19 –Removing the Fuel Filter Cup

Spark Plug Maintenance

The spark plug is important for proper engine operation. A good spark plug should be intact, free of deposits, and properly gapped. To inspect your spark plug:

1. Pull on the spark plug cap to remove it.
2. Unscrew the spark plug from the generator using the spark plug wrench included with this product (see figure 20).
3. Visually inspect the spark plug. If it is cracked or chipped, discard and replace with a new spark plug. We recommend using a F6RTC spark plug such as NGKBPR5ES.
4. Measure the plug gap with a gauge (see figure 21). The gap should be 0.7-0.8 nun (0.028-0.031 in).
5. If you are re-using the spark plug, use a wire brush to clean any dirt from around the spark plug base and then re-gap the spark plug.
6. Screw the spark plug back into its place on the generator using the spark plug wrench. Replace the spark plug cap.

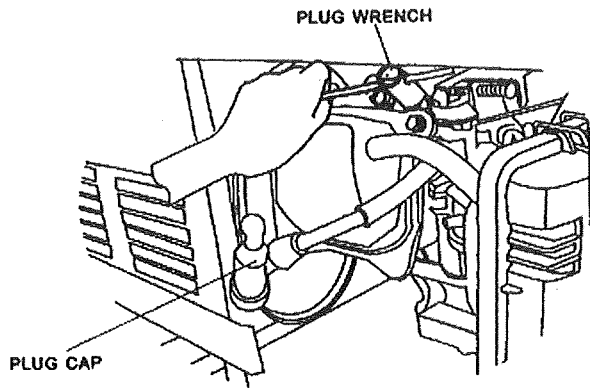

Figure 20- Removing the spark plug

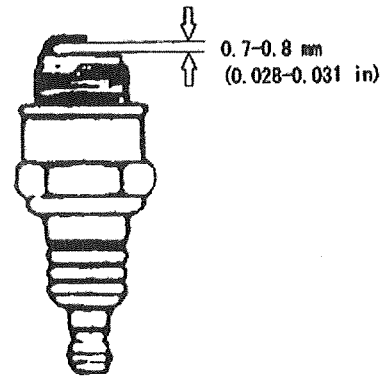

Figure 21- Measuring the spark plug gap

Emptying the Gas Tank

Before storing your generator for extended periods of time, you should drain your generator of gasoline. To drain the generator of gas:

1. Turn the fuel valve to the "OFF" position.
2. Remove the fuel filter cup (see "*Removing the Fuel Filter Cup*" earlier in this section).
3. Empty the fuel filter cup of any fuel.
4. With a receptacle underneath the generator to catch the gas, turn the fuel valve to the "ON" position. Drain all the gas from the generator.
5. Turn the fuel valve to the "OFF" position.
6. Replace the fuel filter cup.
7. Store the emptied gasoline in a suitable place.

⚠ CAUTION: Do not store fuel from one season to another.

STORAGE/TRANSPORT PROCEDURES

⚠ CAUTION: Never place any type of storage cover on the generator while it is still hot.

When transporting or storing your generator for extended periods of time:

- Empty the gas tank (see "*Emptying the Gas Tank*" in the "*Maintenance*" section).
- Disconnect the spark plug.
- Do not obstruct any ventilation openings.
- Keep the generator in a cool dry area.

GENERATOR SPECIFICATIONS

AC Output

	XP4400	XP4400E
Rated Wattage	3500W	3500W
Surge Wattage	4400W	4400W
Rated Voltage	120/240V	120/240V
Rated Frequency	60Hz	60Hz
Phase	Single	Single

DC Output

	XP4400	XP4400E
Voltage	12V	12V
Amperage	8.3A	8.3A
Dimensions (in):	Length=23.2 Width=17 Height=17	Length=23.2 Width=17 Height=17

Engine

	XP4400	XP4400E
Engine type	4-stroke OHV single cylinder with forced air cooling system	
Ignition system	Non-contact transistor	
Displacement	200cc	
Starting type	Recoil	Electric
Fuel tank capacity:	15L(3.96US gal.)	
Oil capacity	0.6L(20fl oz.)	
Run time on 50% load	14hrs	12 hrs
Noise Level	< 69dB	

TROUBLESHOOTING

Problem	Cause	Solution
Engine will not start	Engine switch is set to "OFF".	Set engine switch to "ON".
	Fuel valve is turned to "CLOSED".	Turn fuel valve to "OPEN" position.
	Choke is open.	Close the choke
	Engine is out of gas.	Add gas.
	Engine is filled with contaminated or old gas	Change the gas on the engine.
Engine will not start	Spark plug is dirty.	Clean spark plug.
	Spark plug is broken.	Replace spark plug.

(continued from page 19)	Generator is not on level surface.	Move generator to a level surface to prevent low oil shutdown from triggering.
	Oil is low	Add or replace oil.
Engine runs but there is no electrical output	Circuit breaker is off.	Set the circuit breaker to the "ON" position.
	Bad connecting wires/cables.	If you are using an extension cord, try a different one.
	Bad electrical device connected to generator.	Try connecting a different device.
Generator runs but does not support all electrical devices connected.	Generator is overloaded	Try connecting fewer electrical loads to the generator.
	Shorten one of the connected devices.	Try disconnecting any faulty or short-circuited electrical loads.
	Air cleaner is dirty.	Clean or replace air cleaner.

GENERATOR ASSEMBLY AND MOUNTING

Generator is supplied with a wheel kit. If you want to install the wheel kit on your unit, please follow the instructions below. If you will not be using the wheel kit, skip this section.

1. Place the bottom of the generator cradle on a flat, even surface. Temporarily place unit on blocks to ease assembly.
2. Secure the support leg to the cradle with cap screws (M8 x 16) and lock nuts (M8) (see *figure 22*).
3. Secure the axle to the cradle with cap screws (M8 x 16) and lock nuts (M8) (see *figure 23*).
4. Slide a wheel (with the inflation valve facing out) and a flat washer over the axle, then secure the wheel with a retaining pin (see *figure 24, Figure 25, Figure 26*).
5. Position the handles on the cradle and attach with plastic flat washer, cap screws (M8 X 16) and lock nuts(M8)(*Figure 27, Figure 28*).
6. Check that all fasteners are tight and tires are inflated between 15-40 PSI.



Figure 22



Figure 23

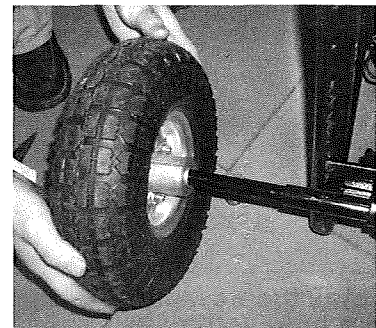

Figure 24

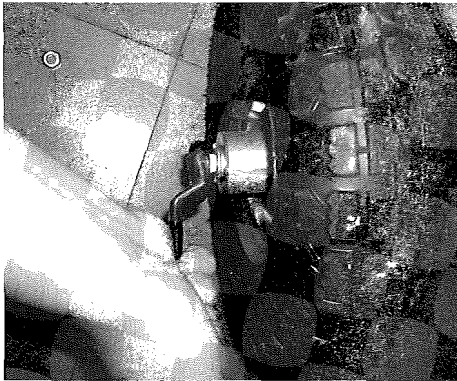

Figure 25

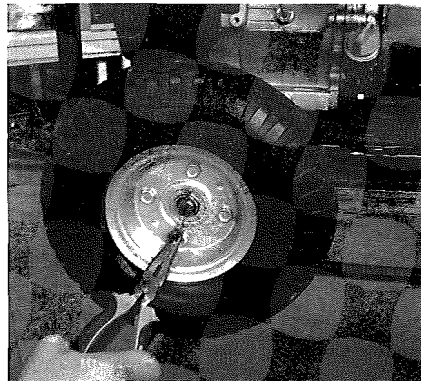

Figure 26

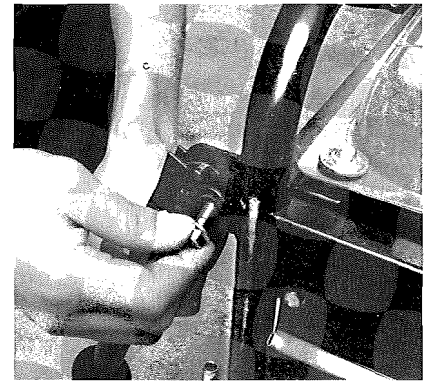

Figure 27

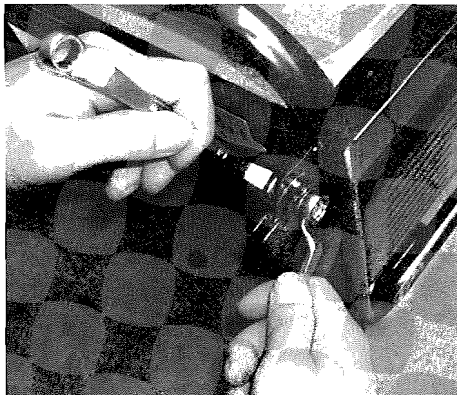
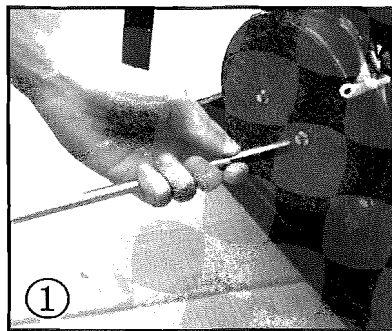
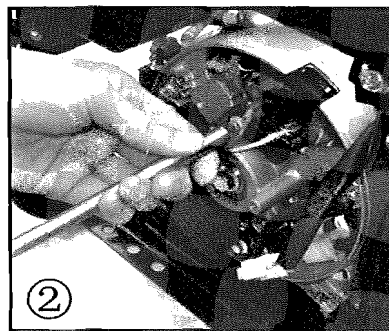

Figure 28

CHANGE THE CARBON-BRUSH



① Dismantle the 2 bolts (M5X12) of electric machine back-cover.



② Take down the installed bolts (M5X16) of carbon-brush.

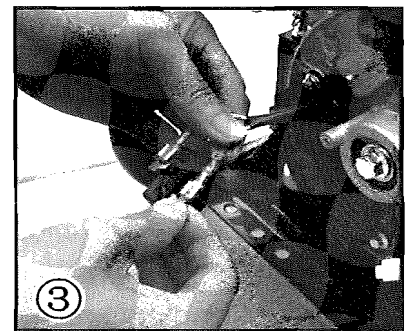

③ Take down the carbon-brush from DC wire of excitation.

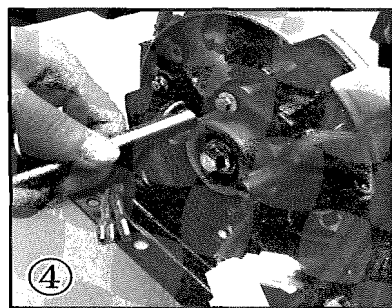

④ Install the new carbon-brush with bolts (M5X16).



⑤ Insert and connect the DC wire of excitation according to anode-cathode.

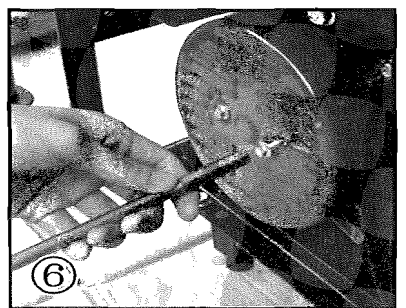

⑥ Install the electric machine back-cover with 2 bolts (M5X12).

CHANGE THE AVR

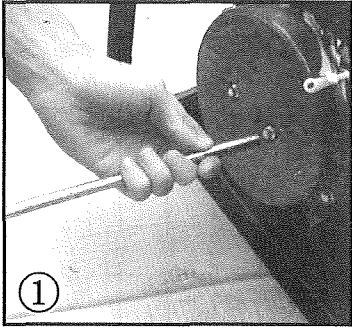

① Dismantle the 2 bolts (M5X12) of electric machine back-cover.

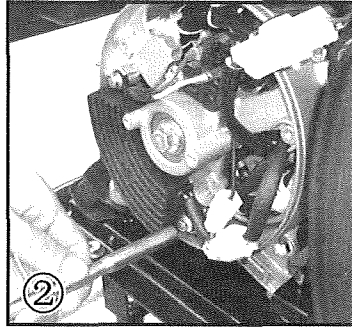

② Take down the 2 installed bolts (M5X16) of AVR.

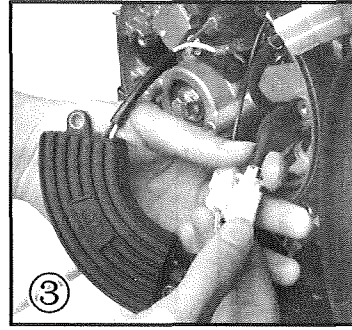

③ Disconnect the sample wire hindered.

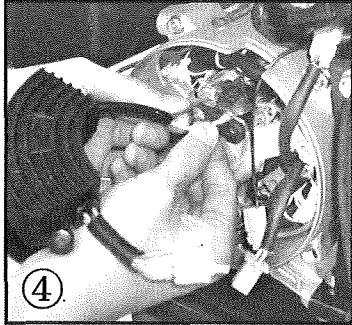

④ Take down the AVR from carbon-brush

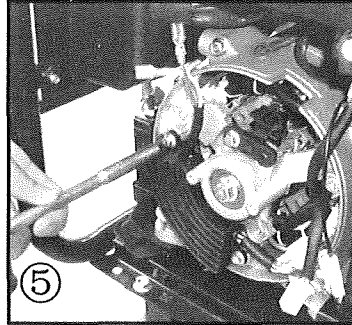

⑤ Install the new AVR with 2 bolts (M5X16)

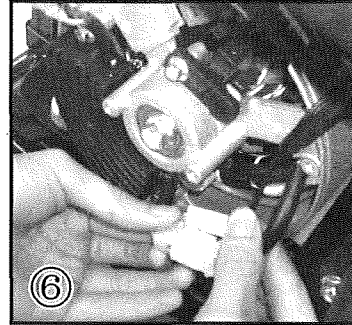

⑥ Connect the sample wire hindered.

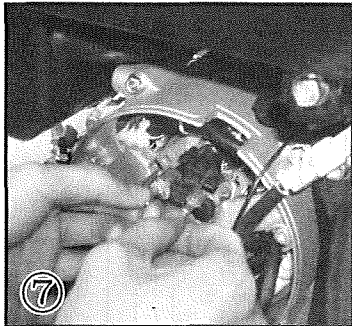

⑦ Insert and connect the DC wire of excitation according to anode-cathode.

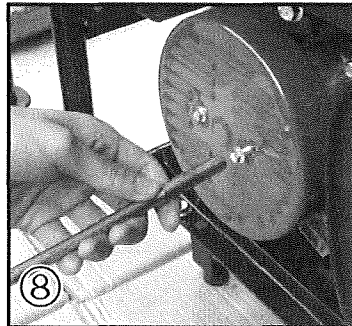

⑧ Install the electric machine back-cover with 2 bolts (M5 X12)

WIRING DIAGRAM (XP4400)

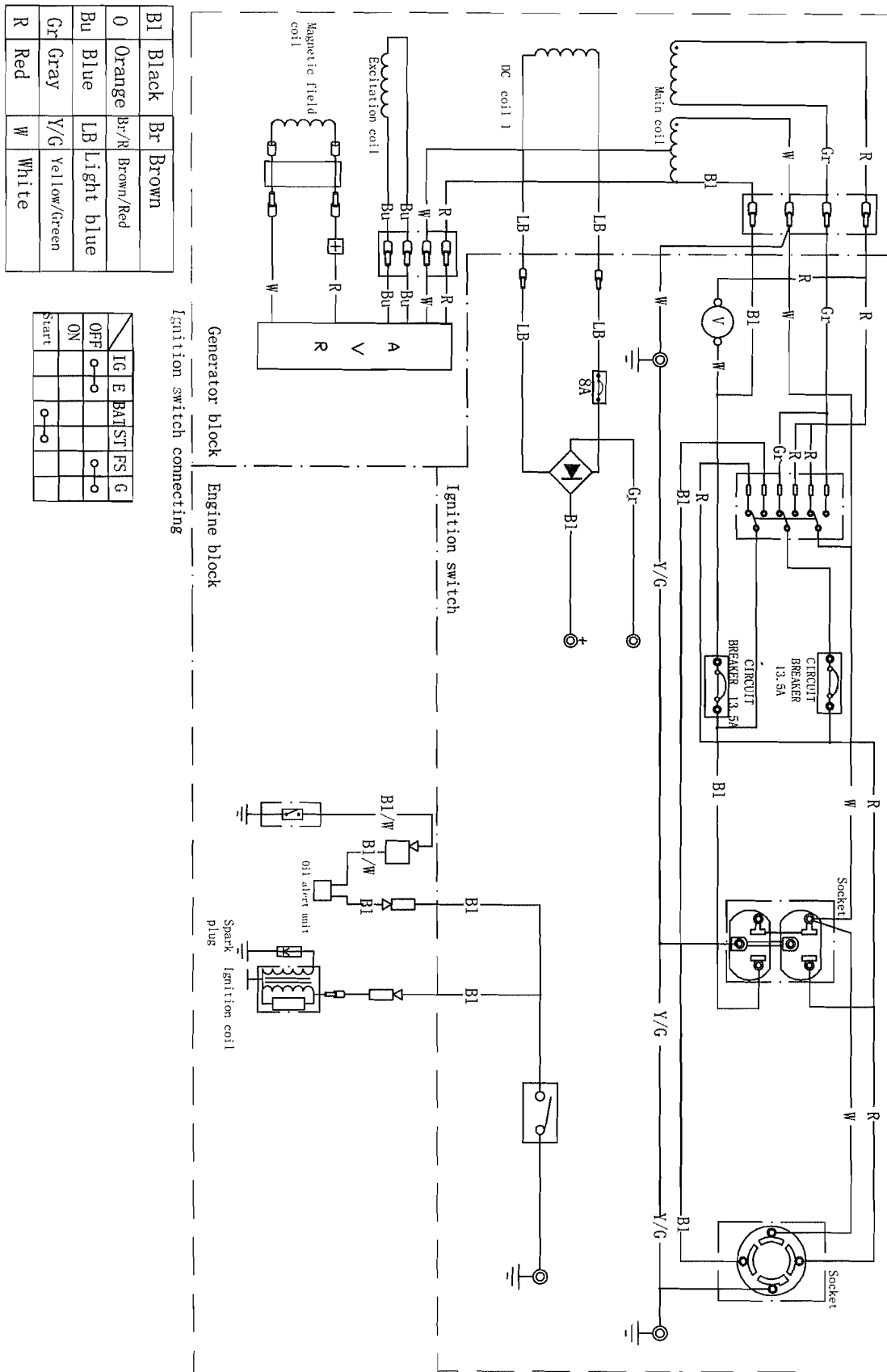

B1	Black	Br	Brown
0	Orange	Br/R	Brown/Red
Bu	Blue	LB	Light blue
Gt	Gray	Y/G	Yellow/Green
R	Red	W	White

IG	E	BAT	ST	FS	G
ON	OFF	ON	OFF	ON	OFF
Start					

WIRING DIAGRAM OF 120V/240V GENERATOR SET

WIRING DIAGRAM (XP4400E)

WIRING DIAGRAM OF 120V/240V GENERATOR SET

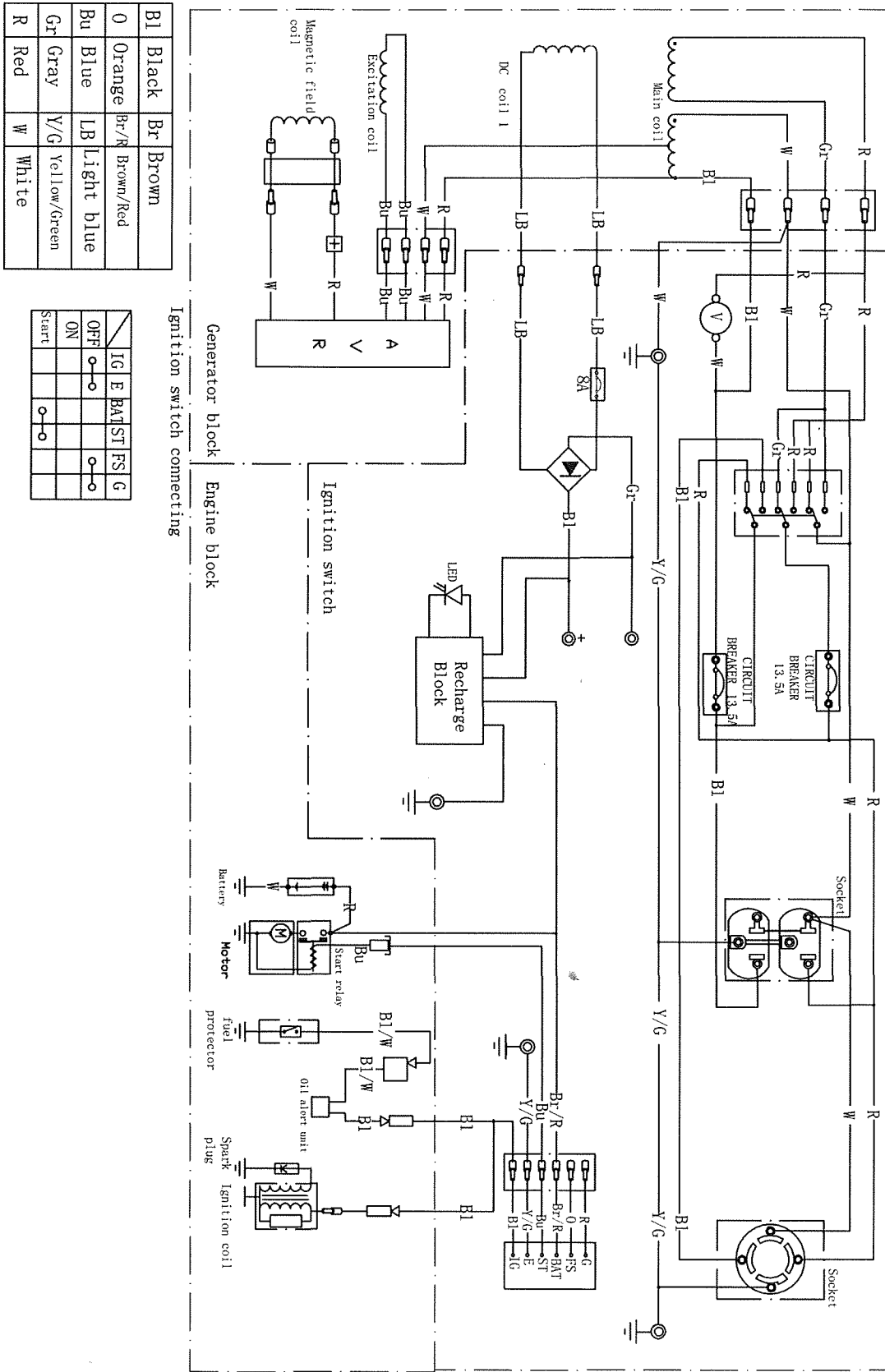

B1	Black	Br	Brown
0	Orange	Br/R	Brown/Red
Bu	Blue	LB	Light blue
Gr	Gray	Y/G	Yellow/Green
R	Red	W	White

IG	E	BAT	ST	FS	G
OFF	ON				
Start					

EXPLODED VIEW AND PARTS LIST (XP4400)

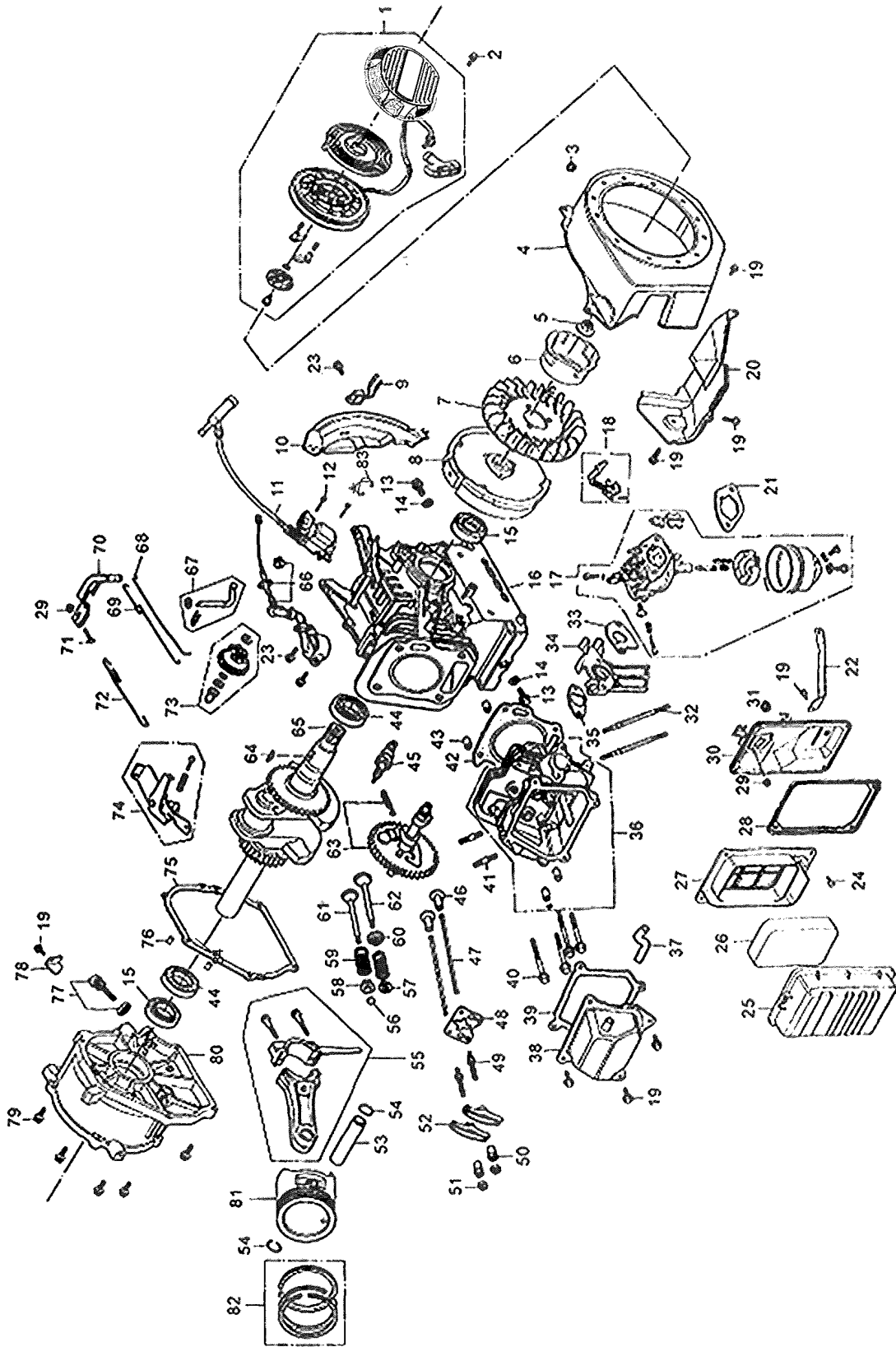

Ite	Part	Qt	Description	Ite	Part	Qt	Description
-----	------	----	-------------	-----	------	----	-------------

Item	Part	Qty	Description	Item	Part	Qty	Description
1	DJ168F-16121-K	1	Recoil Sarer	43	DJ168F-11009-A	2	Set Pin, 10×14
2	GBT5787-B6-8	4	Bolt Flange M6×8	44	GB276-89-6205	2	Radial ball bearing (6025)
3	DJ168F-16118	1	Grommet drain hole	45	DJ168F-18500-A	1	Spark Plug F7TC
4	DJ168F-16120	1	Fan case	46	DJ170F-13009-A	2	Tappet Litter Valve
5	GBT61771/10-N-14	1	Flange nut M14	47	DJ170F-13008-B	2	Rod, push
6	DJ168F-16000-A	1	Starting Cup	48	DJ168F-13300-A	1	Plate, push rod guide
7	DJ168F-16002-A	1	Flywheel Fan	49	DJ168F-13202-A	2	Fastening Bolt
8	DJ168F-16200-C	1	Flywheel	50	DJ168F-13203-A	2	Adjusting Nut
9	DJ168F-18300-A	1	Amplifier	51	DJ168F-13204-A	2	Lock Nut
10	DJ168F-11400-A	1	Wind Shiel Assembly	52	DJ168F-13201-A	2	Arm, valve rocker
11	DJ168F-18100-C	1	Ignition Coil	53	DJ170F-12002-B	1	Pin, piston
12	GBT5787-B6-25	10	Flange bolt M6×25	54	DJ168F-12003-A	2	Clip, piston pin
13	DJ168F-11004-A	2	Drain Plug Washer	55	DJ170F-12200-B	1	Tie-rod Assembly
14	DJ168F-11005-A	2	Washer, drain lug	56	DJ168F-13006-A	1	Rotator, valve
15	DJ168F-11014-A	2	Oil seal, 25×41×6	57	DJ168F-13004-A	1	Retainer, IN. Valve spring
16	DJ170F-11100-F	1	Crank case assy.	58	DJ168F-13005-A	1	Retainer, EX. Valve spring
17	DJ170FD-14100-B	1	Carburetor Assembly	59	DJ168F-13003-A	2	Spring, valve
18	DJ168F-14119	1	Lever comp, choke	60	DJ168F-13010-A	1	Returner, Exhaust Valve
19	GBT5787-B6-16	15	Bolt Flange M6×16	61	DJ168F-13002-A	1	Intake Valve
20	DJ168F-11012-A	1	Air-leading Cover	62	DJ168F-13001-A	1	Exhaust Valve
21	DJ168F-14027-A	1	Air Cleaner Gasket	63	DJ168F-13100-B	1	Camshaft assy.
22	DF2500H-14205-A	1	Stay, air cleaner	64	DJ168F-12104	1	Woodruff Key
23	GBT5787-B6-12	7	Flange bolt M6×12	65	DJ168F-12100-BB	1	Crankshaft Assembly
24	GBT5787-B5-14	4	Flange bolt M5×14	66	DJ168F-18200-A	1	Oil Sensor Assembly
25	DJ168F-14204	1	Air Cleaner Cover	67	DJ168F-15001-A	1	Shaft, governor assy.
26	DJ170F-14201	1	Element, air cleaner	68	DJ168F-15006-A	1	Pulling Rod
27	DJ168F-14202	1	Air Cleaner Housing	69	DJ170F-15008-A	1	Fine Regulating Spring C
28	DJ168F-14206	1	Packing Slip	70	DJ168F-15004-A	1	Speed Regulating Arm
29	GBT6177-N-6	2	Flange nut M6	71	DJ168F-15005-A	1	Lock Bolt
30	DJ168F-14205-A	1	Air Cleaner Base	72	DJ170F-15007-A	1	Back Spring B
31	DJ168F-14014-A	1	Grommet	73	DJ168F-15100-A	1	centrifugal assy.
32	DJ168FD-14001-A	2	Bolt Stud, 6×90	74	DJ168FD-15200-A	1	speed adjuster
33	DJ168F-14005-A	1	Carbretor Gasket	75	DJ170F-11003-B	1	Crankcase Gasket
34	DJ168F-14004-A	1	Connecting Block, Carbretor	76	DJ168F-11002-C	1	Pin, dowel, 9×12
35	DJ168F-14003-B	1	Inlet Gasket	77	DJ168F-11007-A	1	Oil Filler Assembly
36	DJ170F-11200-C	1	Head comp, cylinder	78	DF1800H-33016-A	1	Plat
37	DJ168FD-11013-A	1	Tube, Breather	79	GBT5787-B8-35	6	bolt M8×35
38	DJ168F-11300-C	1	Cylinder Head Cover Assembly	80	DJ168FD-11001-C	1	Crankcase cover
39	DJ168F-11011-A	1	Cylinder Head Cover Gasket	81	DJ170F-12001-B	1	Piston
40	GBT5787-B8-60	4	Flange bolt M8×60	82	DJ170F-12300-A	1	Scraper Ring Set, Piston
41	DJ168F-14002-A	2	Bolt head, M8×35	83	DJ168F-11039-A	1	O-Clip
42	DJ170F-11010-C	1	Casket, cylinder head	84	DJ168F-11002-B	1	Pin, dowel, 7×12

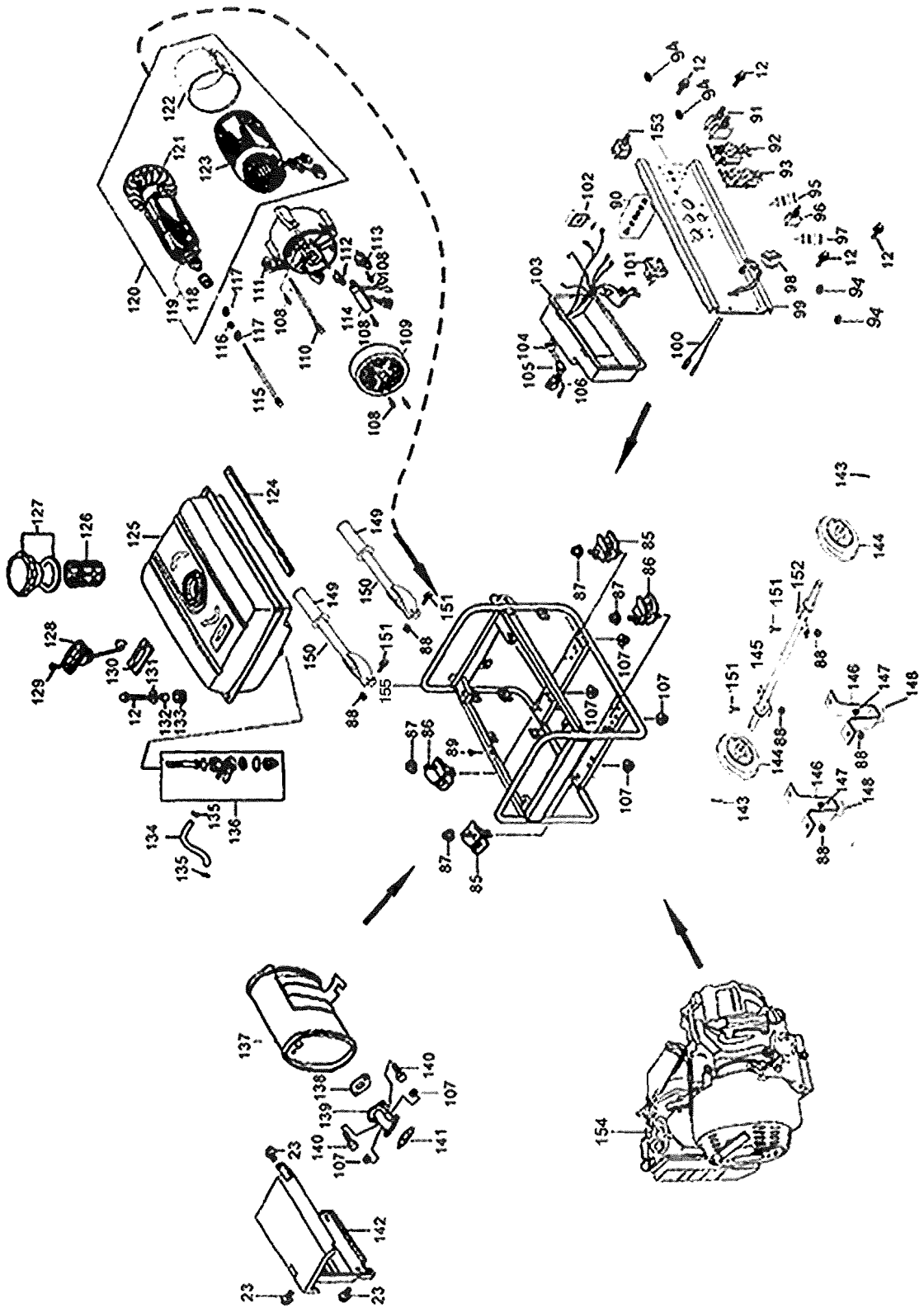

Item	Part	Qty	Description	Item	Part	Qty	Description
85	DF2500H-31201-A	2	Bottom rubber A	127	14306	1	Fuel filler cap comp
86	DF2500H-31202-A	2	Bottom rubber B	128	14303	1	Fuel sensor
87	GBT6177-N-8	4	Flange nut M8	129	GBT819-B-5	2	Screw M5×10
88	GBT889-N-8	10	Flange nut M8	130	14313	1	GASKET,FUEL SENSOR
89	DF2500H-14304-A	1	Rubber Screws, Fuel Tank	131	14311	4	Washer
90	34107	1	Earth terminal set	132	14305	4	Collar
91	34206-100	1	Circuit breaker	133	14304	4	Cushion
92	34204-003	1	4-holes Socket	134	DJ168FD-14007-C	1	Outlet pipeφ4.5×165
93	34204-005	1	3-holes Socket	135	DJ168F-14008-A	2	Tube clip
94	20140	4	Plain Washer	136	DF2500H-14302-A	1	Fuel cock
95	34204-038	1	Output Set, DC A	137	DF2500H-14400-E	1	Muffler
96	34208-004	1	Over-current protector, DC	138	DJ188F-14010-A	1	Gasket , Exhaust Pipe
97	34204-039	1	Output Set, DC B	139	DF2500H-14009	1	Exhaust Pipe
98	34203-004	1	Engine switch	140	GB5787-B-8	2	Flange bolt M8×25
99	XP4400-34101-A	1	Control panel	141	DJ168F-14006-A		Muffler Gasket
100	34213-001	1	Sub Wire Harness Assay	142	DF2500H-14018-B	1	Outer Hood
101	34205-001	1	Voltmeter	143	DF2500H-31019-B	2	φ 3 Clip
102	34210-001	1	Rectifier bridge 30A	144	31017-F	2	Wheel comp
103	34102-A	1	Control panel case	145	DF3000H-31018-F	1	Well shaft
104	34109	1	Boot, main wire harness	146	DF3000H-31070-E	2	Support
105	34117	1	Boot, AC output wire	147	GBT889-N-6	2	Flange nut M6
106	34212-001	1	Boot, main wire harness	148	DF9000H-31204-A	2	Rubber feet
107	GBT6170-N-8	6	Flange nut M8	149	DF6500H-31016-A	2	Rubber Coat, Handle
108	GBT5789-B5-16	8	Flange bolt M5×16	150	DF3800H-31058-C	2	Handle
109	DF1800H-33006-B	1	Generator end cover	151	GBT889-N-8×20	10	Flange bolt M8×20
110	DF3500H-33015-A	4	Flange bolt M6×156	152	DFD3000H-31021-B	1	Axle
111	DF1800H-33005-A	1	GENERATOR STAY	153	34202-006	1	Transfer Switch
112	DF3500H-33001	1	BRUSH ASSEMBLY	154	DJ170N-B	1	Gasoline engine
113	DF3500H-33002	1	Conecting Plate	155	XP4400-31100-B	1	Frame com
114	DF2500H-33011-A	1	Voltage regulator				
115	DF3500H-33003-A	1	Bolt M8×220				
116	GBT93-LW-8	1	Plain washer φ8				
117	GBT97-W-8	2	Plain Washer				
118	GB276-89-6204	1	Bearing 6204-2RS				
119	DF3500H-33110-B	1	ROTOR ASSEMBLY				
120	DF3000H33103-B-2360 2	1	Stator & Rotor Assy.				
121	DF2500H-33023	1	Generator fan				
122	DF3500H-33129	1	Stator cover				
123	DF3500H-33120	1	Stator Assy.				
124	DF2500H-14304-A	1	rubber belt				
125	DF2500H-14300-B	1	Fuel tank				
126	14307	1	Fuel filter				

EXPLODED VIEW AND PARTS LIST (XP4400E)

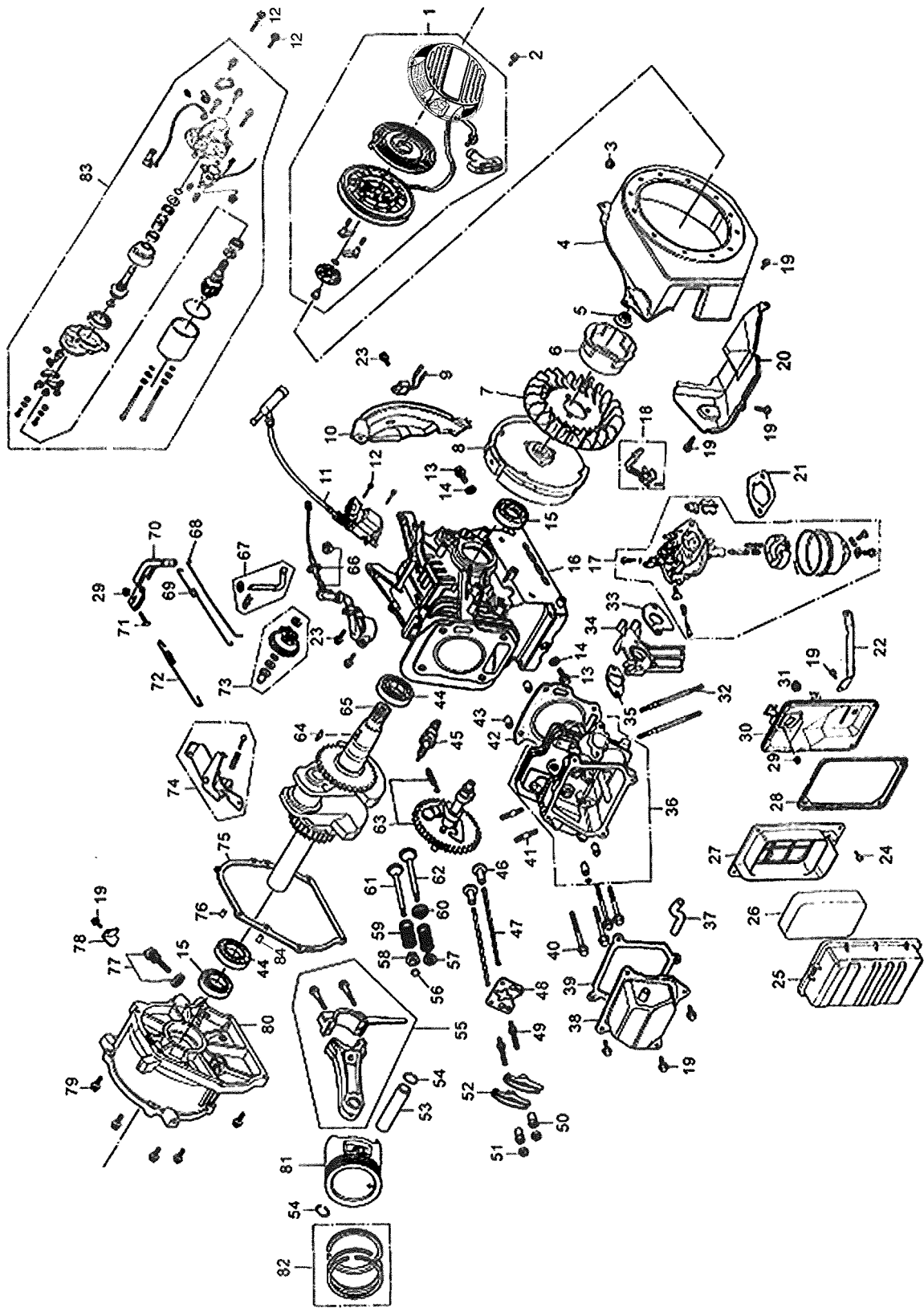

Item	Part	Qty	Description	Item	Part	Qty	Description
1	DJ168F-16121-K	1	Recoil Sarer	43	DJ168F-11009-A	2	Set Pin, 10×14
2	GBT5787-B6-8	4	Bolt Flange M6×8	44	GB276-89-6205	2	Radial ball bearing (6025)
3	DJ168F-16118	1	Grommet drain hole	45	DJ168F-18500-A	1	Spark Plug F7TC
4	DJ168FB-16120	1	Fan case	46	DJ170F-13009-A	2	Tappet Litter Valve
5	GBT61771/10-N-14	1	Flange nut M14	47	DJ170F-13008-B	2	Rod, push
6	DJ168F-16000-A	1	Starting Cup	48	DJ168F-13300-A	1	Plate, push rod guide
7	DJ168F-16002-A	1	Flywheel Fan	49	DJ168F-13202-A	2	Fastening Bolt
8	DJ168F-16200-I	1	Flywheel	50	DJ168F-13203-A	2	Adjusting Nut
9	DJ168F-18300-A	1	Amplifier	51	DJ168F-13204-A	2	Lock Nut
10	DJ170S-11400-A	1	Wind Shiel Assembly	52	DJ168F-13201-A	2	Arm, valve rocker
11	DJ168F-18100-C	1	Ignition Coil	53	DJ170F-12002-B	1	Pin, piston
12	GBT5787-B6-25	4	Flange bolt M6×25	54	DJ168F-12003-A	2	Clip, piston pin
13	DJ168F-11004-A	2	Drain Plug Washer	55	DJ170F-12200-B	1	Tie-rod Assembly
14	DJ168F-11005-A	2	Washer, drain lug	56	DJ168F-13006-A	1	Rotator, valve
15	DJ168F-11014-A	2	Oil seal, 25×41×6	57	DJ168F-13004-A	1	Retainer, IN. Valve spring
16	DJ170F-11100-F	1	Crank case assy.	58	DJ168F-13005-A	1	Retainer, EX. Valve spring
17	DJ170FD-14100-B	1	Carburetor Assembly	59	DJ168F-13003-A	2.	Spring, valve
18	DJ168F-14119	1	Lever comp, choke	60	DJ168F-13010-A	1	Returned, Exhaust Valve
19	GBT5787-B6-16	15	Bolt Flange M6×16	61	DJ168F-13002-A	1	Intake Valve
20	DJ168F-11012-A	1	Air-leading Cover	62	DJ168F-13001-A	1	Exhaust Valve
21	DJ168F-14027-A	1	Air Cleaner Gasket	63	DJ168F-13100-B	1	Camshaft assy.
22	DF2500H-14205-A	1	Stay, air cleaner	64	DJ168F-12104	1	Woodruff Key
23	GBT5787-B6-12	7	Flange bolt M6×12	65	DJ168F-12100-BB	1	Crankshaft Assembly
24	GBT5787-B5-14	4	Flange bolt M5×14	66	DJ168F-18200-A	1	Oil Sensor Assembly
25	DJ168F-14204	1	Air Cleaner Cover	67	DJ168F-15001-A	1	Shaft, governor assy.
26	DJ170F-14201	1	Element, air cleaner	68	DJ168F-15006-A	1	Pulling Rod
27	DJ168F-14202	1	Air Cleaner Housing	69	DJ170F-15008-A	1	Fine Regulating Spring C
28	DJ168F-14206	1	Packing Slip	70	DJ168F-15004-A	1	Speed Regulating Arm
29	GBT6177-N-6	2	Flange nut M6	71	DJ168F-15005-A	1	Lock Bolt
30	DJ168F-14205-A	1	Air Cleaner Base	72	DJ170F-15007-A	1	Back Spring B
31	DJ168F-14014-A	1	Grommet	73	DJ168F-15100-A	1	centrifugal assy.
32	DJ168FD-14001-A	2	Bolt Stud, 6×90	74	DJ168FD-15200-A	1	speed adjuster
33	DJ168F-14005-A	1	Carburetor Gasket	75	DJ170F-11003-B	1	Crankcase Gasket
34	DJ168F-14004-A	1	Connecting Block,Carbretor	76	DJ168F-11002-C	1	Pin, dowel, 9×12
35	DJ168F-14003-B	1	Inlet Gasket	77	DJ168F-11007-A	1	Oil Filler Assembly
36	DJ170F-11200-C	1	Head comp, cylinder	78	DF1800H-33016-A	1	Plat
37	DJ168FD-11013-A	1	Tube, Breather	79	GBT5787-B8-35	6	bolt M8×35
38	DJ168F-11300-C	1	Cylinder Head Cover Assembly	80	DJ168FD-11001-C	1	Crankcase cover
39	DJ168F-11011-A	1	Cylinder Head Cover Gasket	81	DJ170F-12001-B	1	Piston
40	GBT5787-B8-60	4	Flange bolt M8×60	82	DJ170F-12300-A	1	Scraper Ring Set, Piston
41	DJ168F-14002-A	2	Bolt head, M8×35	83	DJ168F-18600-A	1	Starting Motor Assembly
42	DJ170F-11010-C	1	Casket, cylinder head	84	DJ168F-11002-B	1	Pin, dowel, 7×12

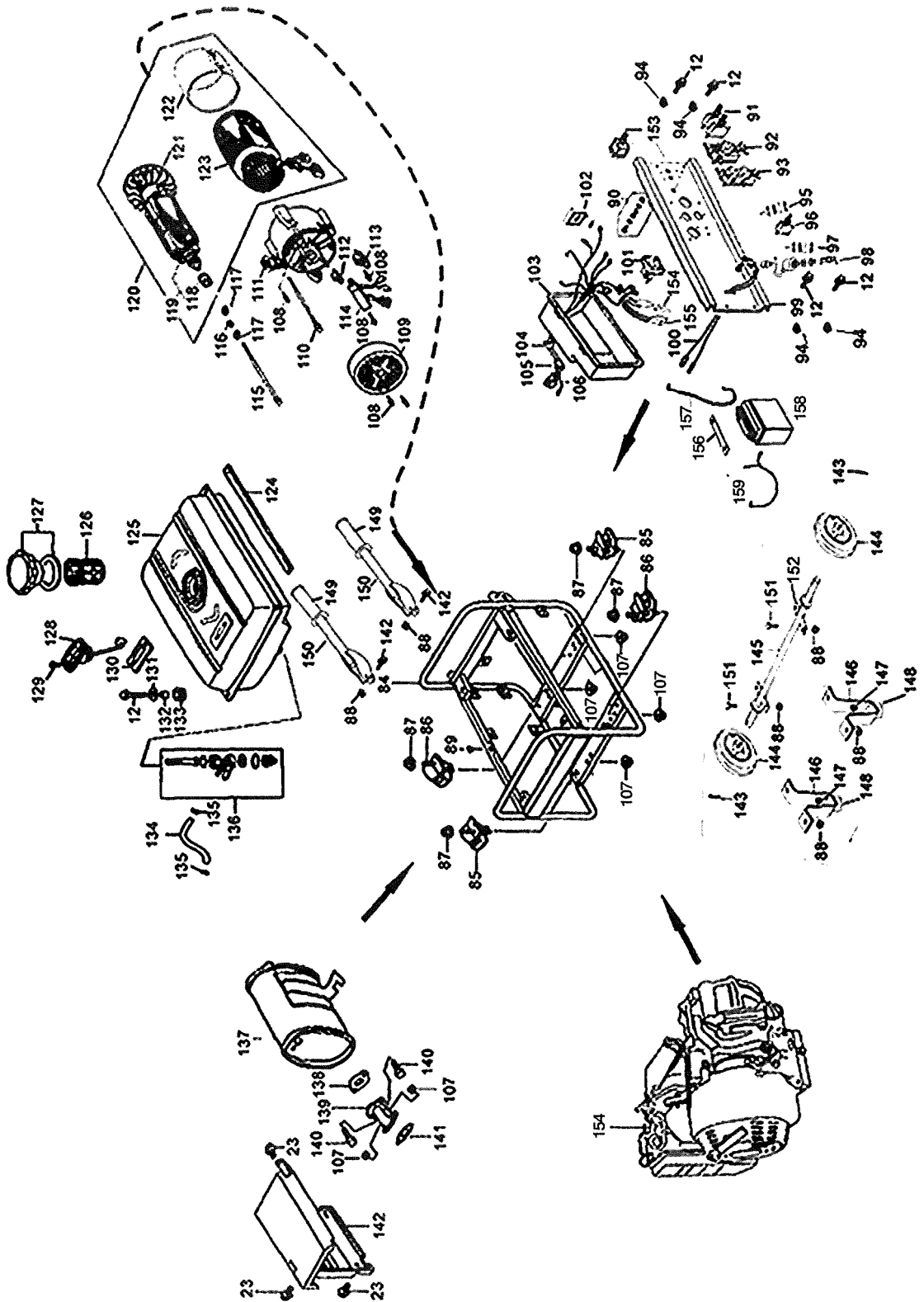

Item	Part	Qty	Description	Item	Part	Qty	Description
84	XP4400E-31100-B	1	Frame comp	125	DF2500H-14300-B	1	Fuel tank
85	DF2500H-31201-A	2	Bottom rubber A	126	14307	1	Fuel filter
86	DF2500H-31202-A	2	Bottom rubber B	127	14306	1	Fuel filler cap comp
87	GBT6177-N-8	4	Flange nut M8	128	14303	1	Fuel sensor
88	GBT889-N-8	10	Flange nut M8	129	GBT819-B-5	2	Screw M5×10
89	DF2500H-14304-A	1	Rubber Screws, Fuel Tank	130	14313	1	GASKET,FUEL SENSOR
90	34107	1	Earth terminal set	131	14311	4	Washer
91	34206-100	1	Circuit breaker	132	14305	4	Collar
92	34204-003	1	4-holes Socket	133	14304	4	Cushion
93	34204-005	1	3-holes Socket	134	DJ168FD-14007-C	1	Outlet pipeφ4.5×165
94	20140	4	Plain Washer	135	DJ168F-14008-A	2	Tube clip
95	34204-038	1	Output Set, DC A	136	DF2500H-14302-A	1	Fuel cock
96	34208-004	1	Over-current protector, DC	137	DF2500H-14400-E	1	Muffler
97	34204-039	1	Output Set, DC B	138	DJ188F-14010-A	1	Gasket , Exhaust Pipe
98	34203-002	1	Engine switch	139	DF2500H-14009	1	Exhaust Pipe
99	XP4400E-34101-A	1	Control panel	140	GB5787-B-8	2	Flange bolt M8×25
100	34213-002	1	Sub Wire Harness Assay	141	DJ168F-14006-A		Muffler Gasket
101	34205-001	1	Voltmeter	142	DF2500H-14018-B	1	Outer Hood
102	34210-001	1	Rectifier bridge 30A	143	DF2500H-31019-B	2	φ 3 Clip
103	34102-A	1	Control panel case	144	31017-F	2	Wheel comp
104	34109	1	Boot, main wire harness	145	DF3000H-31018-F	1	Well shaft
105	34117	1	Boot, AC output wire	146	DF3000H-31070-E	2	Support
106	34212-001	1	Boot, main wire harness	147	GBT889-N-6	2	Flange nut M6
107	GBT6170-N-8	6	Flange nut M8	148	DF9000H-31204-A	2	Rubber feet
108	GBT5789-B5-16	8	Flange bolt M5×16	149	DF6500H-31016-A	2	Rubber Coat, Handle
109	DF1800H-33006-B	1	Generator end cover	150	DF3800H-31058-C	2	Handle
110	DF3500H-33015-A	4	Flange bolt M6×156	151	GBT889-N-8×20	10	Flange bolt M8×20
111	DF1800H-33005-A	1	GENERATOR STAY	152	DFD3000H-31021-B	1	Axle
112	DF3500H-33001	1	BRUSH ASSEMBLY	153	34202-006	1	Transfer Switch
113	DF3500H-33002	1	Connecting Plate	154	DJ170N-BD	1	Gasoline engine
114	DF2500H-33011-A	1	Voltage regulator	155	34224-001	1	Charger
115	DF3500H-33003-A	1	Bolt M8×220	156	DF1800H-31033-A	1	Foot
116	GBT93-LW-8	1	Plain washer φ8	157	31040-001	1	Negative Wire of battery
117	GBT97-W-8	2	Plain Washer	158	31300-001	1	7Ah battery
118	GB276-89-6204	1	Bearing 6204-2RS	159	31038-001	1	Positive wire of battery
119	DF3500H-33110-B	1	ROTOR ASSEMBLY				
120	DF3000H33103-B-2360 2	1	Stator & Rotor Assy.				
121	DF2500H-33023	1	Generator fan				
122	DF3500H-33129	1	Stator cover				
123	DF3500H-33120	1	Stator Assy.				
124	DF2500H-14304-A	1	rubber belt				

