



Instruction Manual

Rice Cooker & Food Steamer



Questions or concerns about your rice cooker?

Before returning to the store...



Aroma's customer service experts are happy to help. Call us toll-free at **1-800-276-6286**.



Answers to many common questions and even replacement parts can be found online. Visit **www.AromaCo.com/Support**.

Congratulations on your purchase of the Aroma® Professional™ 12-Cup Digital Rice cooker! In no time at all, you'll be making fantastic, restaurant-quality rice at the touch of a button. Whether long, medium or short grain, this cooker is specially calibrated to prepare a variety of rice, including tough-to-cook whole grain brown rice, to fluffy perfection.

In addition to rice, your new Aroma® Professional™ rice cooker is ideal for healthy, one-pot meals for the whole family. The convenient steam tray inserts directly over the rice, allowing you to cook fresh meats and vegetables at the same time, in the same pot. Steaming foods locks in their natural flavor and nutrients without added oil or fat, for meals that are as nutritious as they are easy. But it doesn't end there. Your new rice cooker is also great for soup, stew, gumbo, jambalaya, breakfast frittata, dips and even desserts! Several delicious recipes are included at the back of this manual, and even more are available online at www.AromaCo.com.

This manual contains instructions for using your rice cooker and its convenient pre-programmed digital settings, as well as all of the accessories included. There are also helpful measurement charts for cooking rice and steaming.

For more information on your Aroma® Professional™ rice cooker, or for product service, recipes and other home appliance solutions, please visit us online at www.AromaCo.com.



Visit AromaCo.com/cookn to download your free Cook'n® Recipe Browser

- Capture online recipes and organize them in electronic cookbooks
- Receive exclusive recipes from Aroma® and Mahatma®/Carolina® rice
- Get nutrition facts for all your favorite dishes
- Create menu plans
- Organize shopping lists

...and so much more!

Published By:
Aroma Housewares Co.
6469 Flanders Drive
San Diego, CA 92121
U.S.A.

1-800-276-6286

www.AromaCo.com

©2012 Aroma Housewares Company

All rights reserved.



IMPORTANT SAFEGUARDS

Basic safety precautions should always be followed when using electrical appliances, including the following:

1. Important: Read all instructions carefully before first use.

2. Do not touch hot surfaces. Use the handles or knobs.
3. Use only on a level, dry and heat-resistant surface.
4. To protect against fire, electric shock and injury to persons, do not immerse cord, plug or the appliance in water or any other liquid. See instructions for cleaning.
5. Close supervision is necessary when the appliance is used by or near children.
6. Unplug from outlet when not in use and before cleaning. Allow unit to cool before putting on or taking off parts and before cleaning the appliance.
7. Do not operate any appliance with a damaged cord or plug or after the appliance malfunctions or has been damaged in any manner. Contact Aroma® customer service for examination, repair or adjustment.
8. The use of accessory attachments not recommended by Aroma® Housewares may result in fire, electrical shock or injury.
9. Do not use outdoors.
10. Do not let cord touch hot surfaces or hang over the edge of a counter or table.
11. Do not place on or near a hot gas or electric burner or in a heated oven.
12. Do not use the appliance for other than its intended use.
13. Extreme caution must be used when moving the appliance containing rice, hot oil or other liquids.
14. Do not touch, cover or obstruct the steam vent on the top of the rice cooker as it is extremely hot and may cause scalding.
15. Use only with a 120V AC power outlet.
16. Always unplug from the base of the wall outlet. Never pull on the cord.
17. The rice cooker should be operated on a separate electrical circuit from other operating appliances. If the electrical circuit is overloaded with other appliances, the appliance may not operate properly.
18. Always make sure the outside of the inner cooking pot is dry prior to use. If the inner pot is returned to the cooker when wet, it may damage or cause the product to malfunction.
19. Use extreme caution when opening the lid during or after cooking. Hot steam will escape and may cause scalding.
20. Rice should not be left in the inner cooking pot with the “Keep Warm” function on for more than 12 hours.
21. To prevent damage or deformation, do not use the inner cooking pot on a stovetop or burner.
22. To disconnect, turn any control to “OFF,” then remove the plug from the wall outlet.
23. To reduce the risk of electrical shock, cook only in the removable inner cooking pot provided.

SAVE THESE INSTRUCTIONS



IMPORTANT SAFEGUARDS CONT.

Short Cord Instructions

1. A short power-supply cord is provided to reduce the risks resulting from becoming entangled in or tripping over a longer cord.
2. Longer extension cords are available and may be used if care is exercised in their use.
3. If a longer extension cord is used:
 - a. The marked electrical rating of the extension cord should be at least as great as the electrical rating of the appliance.
 - b. The longer cord should be arranged so that it will not drape over the counter top or tabletop where it can be pulled by children or tripped over unintentionally.

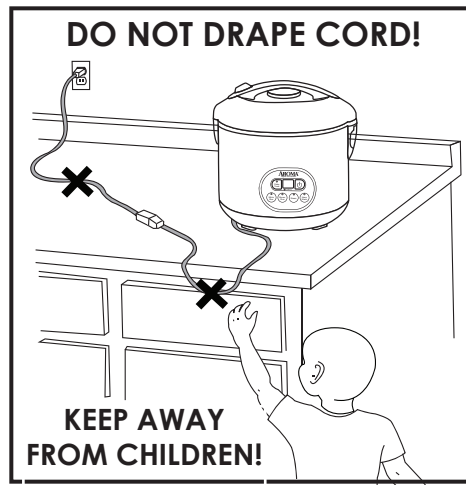

Polarized Plug

This appliance has a **polarized plug** (one blade is wider than the other); follow the instructions below:

To reduce the risk of electric shock, this plug is intended to fit into a polarized outlet only one way. If the plug does not fit fully into the outlet, reverse the plug. If it still does not fit, contact a qualified electrician. Do not attempt to modify the plug in any way.

If the supply cord is damaged, it must be replaced by the manufacturer, its service agent or a similarly qualified person in order to avoid a hazard.

THIS APPLIANCE IS FOR HOUSEHOLD USE ONLY.



PARTS IDENTIFICATION

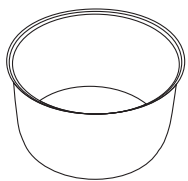
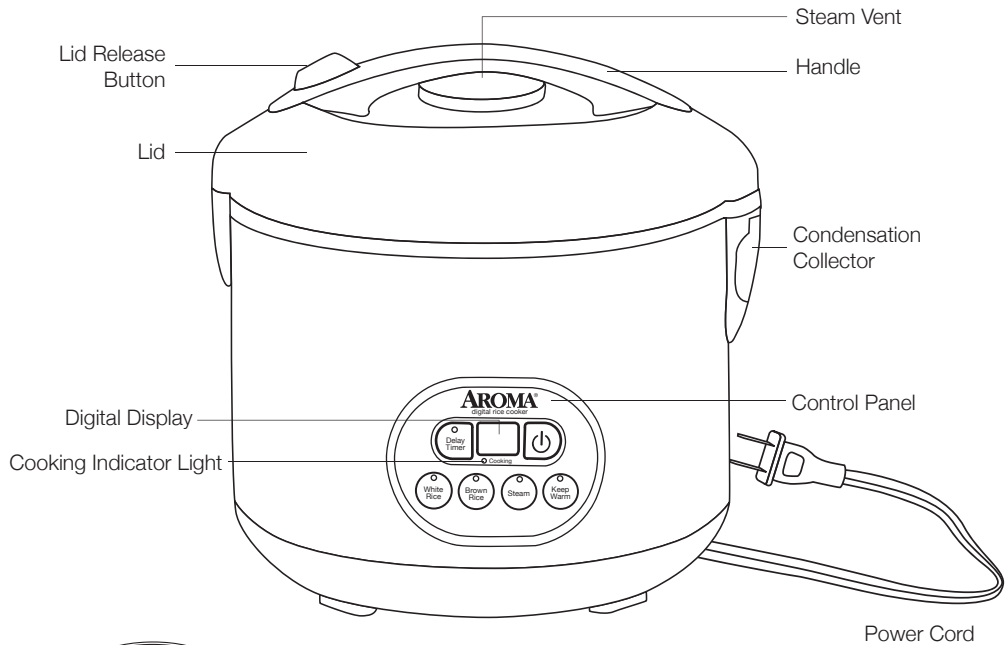

Inner Pot

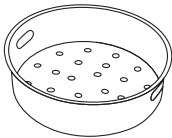

Steam Tray



Measuring Cup



Serving Spatula

Digital Controls



The **POWER** button turns on the rice cooker once it is plugged in.



The **DELAY TIMER** button allows for rice to be ready right when it's needed. Add rice and water in the morning and come home to delicious warm rice ready to eat.



The **WHITE RICE** button cooks restaurant-quality rice automatically.



The **BROWN RICE** button is ideal for cooking brown rice and other tough-to-cook whole grains to perfection.



The **STEAM** button is perfect for quickly steaming delicious meats and vegetables.



The **KEEP WARM** button is great for serving and re-heating.



BEFORE FIRST USE

1. Read all instructions and important safeguards.
2. Remove all packaging materials and check that all items have been received in good condition.
3. Tear up all plastic bags as they can pose a risk to children.
4. Wash steam vent and all other accessories in warm, soapy water. Rinse and dry thoroughly.
5. Remove the inner cooking pot from rice cooker and clean with warm, soapy water. Rinse and dry thoroughly.
6. Wipe body clean with a damp cloth.



NOTE

- Do not use abrasive cleaners or scouring pads.
- Do not immerse the rice cooker base, cord or plug in water at any time.



TO COOK RICE

1

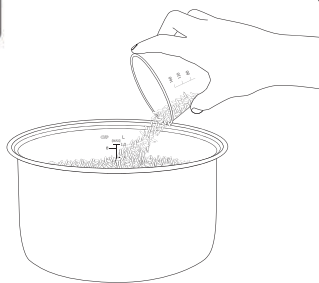

Using the provided measuring cup, add rice to the inner cooking pot.

2

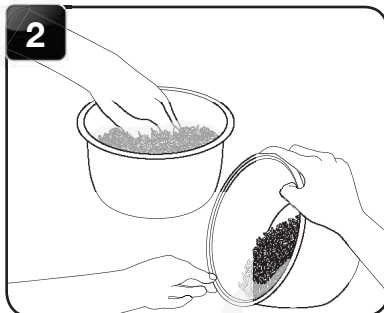

Rinse rice to remove excess starch. Drain.

3

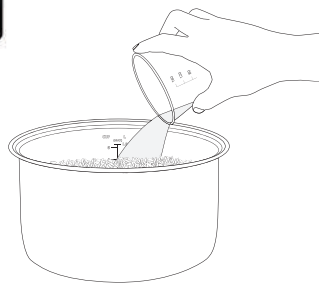

Fill the inner cooking pot with water to the line which matches the number of cups of rice being cooked.

4

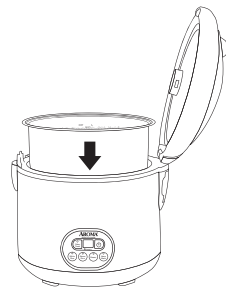

Place the inner cooking pot into the rice cooker.



NOTE

- Before placing the inner cooking pot into the rice cooker, check that it is dry and free of debris. Adding the inner cooking pot when wet may damage the rice cooker.



HELPFUL HINTS

- If you misplace the measuring cup, a $\frac{3}{4}$ standard US cup is an exact replacement.
- To add more flavor to rice, try substituting a favorite meat or vegetable broth or stock. The ratio of broth/stock to rice will be the same as water to rice.
- For approximate rice cooking times and suggested rice/water ratios, see the "Rice/Water Measurement Table" on **page 8**.



TO COOK RICE (CONT.)

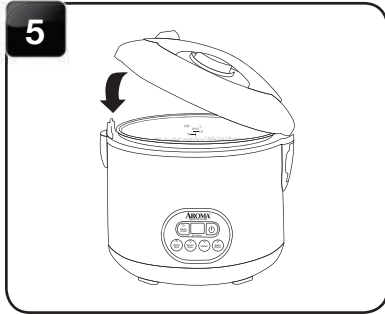

Close the lid securely.

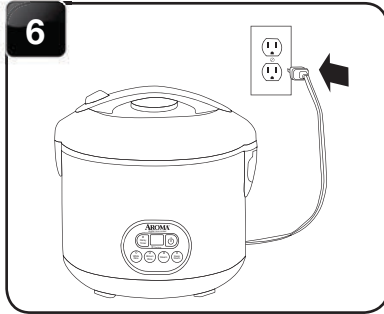

Plug the cord into an available outlet.

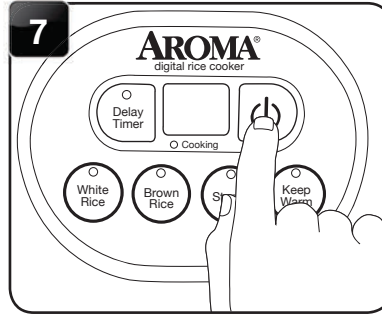

Press the **POWER** button to turn the rice cooker on.

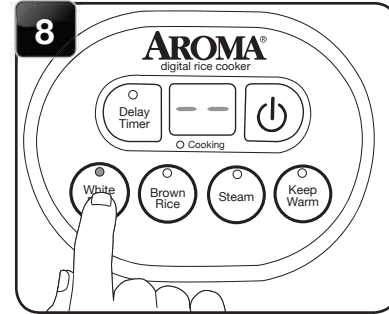

Press the **WHITE RICE** or **BROWN RICE** button, depending on the type of rice being cooked.

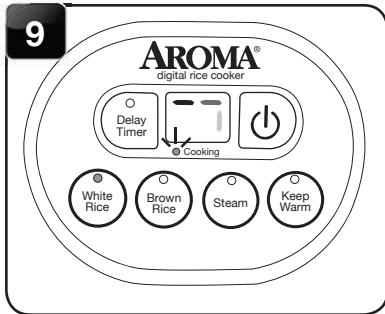

The rice cooker will now begin cooking. The **COOKING** indicator light will illuminate and the digital display will show a “chasing” pattern.

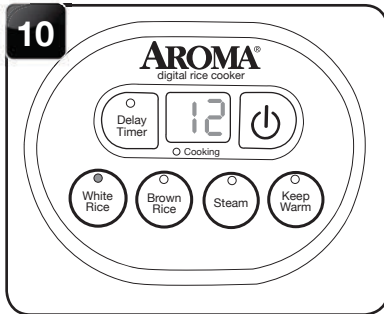

The rice cooker will countdown the final minutes of cook time (12 minutes for white rice and 25 minutes for brown rice).



HELPFUL HINTS

- Pressing the **POWER** button once at any time will cancel the current function.
- Brown rice requires a much longer cooking cycle than other rice varieties due to the extra bran layers on the grains. The “Brown Rice” function on this rice cooker allows extra time and adjusted heat settings in order to cook the rice properly. If it appears the rice cooker is not heating up immediately on the “Brown Rice” setting, this is due to a low-heat soak cycle that precedes the cooking cycle to produce better brown rice results.



TO COOK RICE (CONT.)

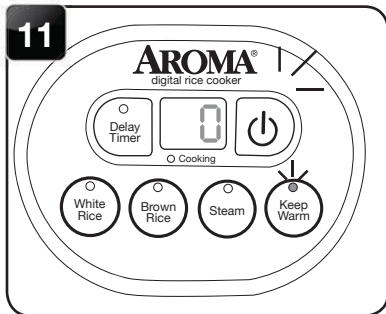

11 Once rice is finished, the rice cooker will beep and automatically switch to its “Keep Warm” setting. The digital display will show the number of hours the rice cooker has been on “Keep Warm,” beginning with “0.”

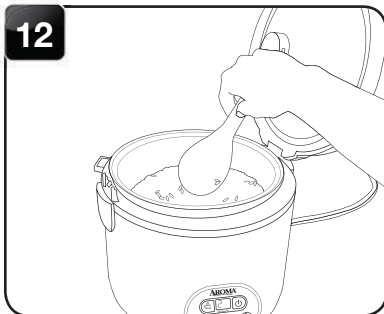

12 For best results, stir the rice with the serving spatula to distribute any remaining moisture.

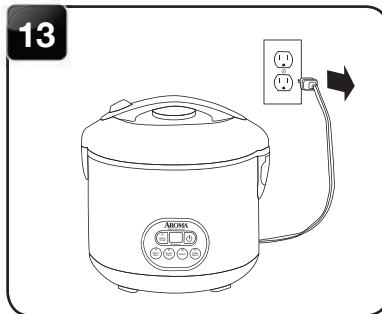

13 When finished serving rice, turn the rice cooker off by pressing the POWER button twice and unplug the power cord.



NOTE

- Rice should not be left in the rice cooker on its “Keep Warm” setting for more than 12 hours.



RICE/WATER MEASUREMENT TABLE

UNCOOKED RICE	RICE WATER LINE INSIDE POT	APPROX. COOKED RICE YIELD	COOKING TIMES
2 Cups	Line 2	4 Cups	WHITE RICE: 30-35 Min. BROWN RICE: 60-65 Min.
3 Cups	Line 3	6 Cups	WHITE RICE: 32-37 Min. BROWN RICE: 65-70 Min.
4 Cups	Line 4	8 Cups	WHITE RICE: 35-42 Min. BROWN RICE: 70-75 Min.
5 Cups	Line 5	10 Cups	WHITE RICE: 40-45 Min. BROWN RICE: 75-80 Min.
6 Cups	Line 6	12 Cups	WHITE RICE: 42-47 Min. BROWN RICE: 80-85 Min.



HELPFUL HINTS

- Rinse rice before placing it into the inner cooking pot to remove excess bran and starch. This will help reduce browning and sticking to the bottom of the pot.
- Want perfect brown rice without the wait? Use the “Delay Timer.” Simply add rice and water in the morning and set the “Delay Timer” for when rice will be needed that night. See “To Use The Delay Timer” on **page 9** for more details.
- This chart is only a general measuring guide. As there are many different kinds of rice available (see “About Rice” on **page 20**), rice/water measurements may vary.

15 TO USE THE DELAY TIMER

Follow steps 1 to 7 of "To Cook Rice" beginning on page 5.

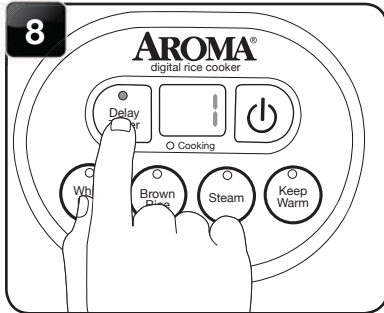

Press the **DELAY TIMER** button. Each press increases in one hour increments. It may be set to have rice ready in 1 to 15 hours.

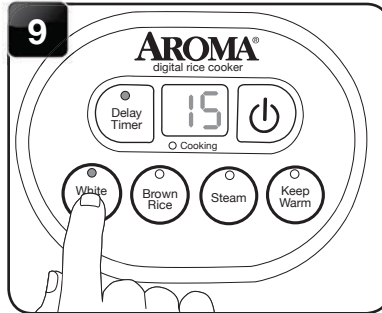

Once the needed time is selected, press the **WHITE RICE** or **BROWN RICE** button, depending on the rice being cooked.

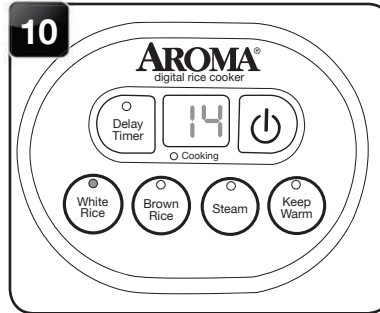

The digital display will countdown from the time selected and begin cooking.

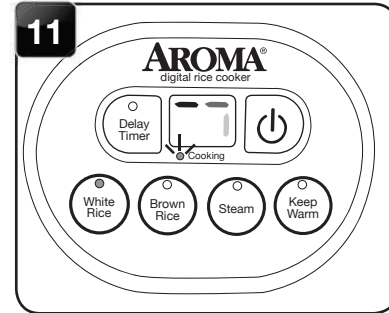

Once rice begins cooking, the **COOKING** indicator light will illuminate and the digital display will show a "chasing" pattern.



NOTE

- Due to the longer cooking time needed, brown rice may only be delayed for 2 hours or more.



HELPFUL HINTS

- If you misplace the measuring cup, a $\frac{3}{4}$ standard US cup is an exact replacement.
- To add more flavor to rice, try substituting a favorite meat or vegetable broth or stock. The ratio of broth/stock to rice will be the same as water to rice.

15 TO USE THE DELAY TIMER (CONT.)

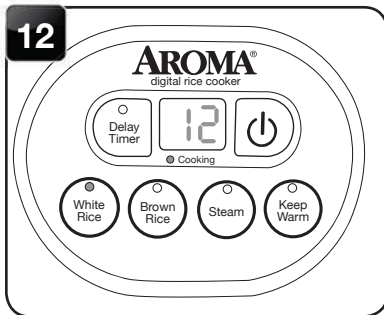

The rice cooker will countdown the final minutes of cook time (12 minutes for white rice and 25 minutes for brown rice).

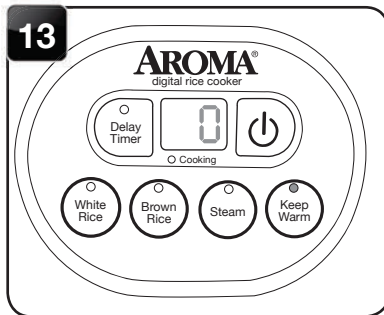

Once rice is finished, the rice cooker will beep and automatically switch to its “Keep Warm” setting. The digital display will show the number of hours the rice cooker has been on “Keep Warm,” beginning with “0.”

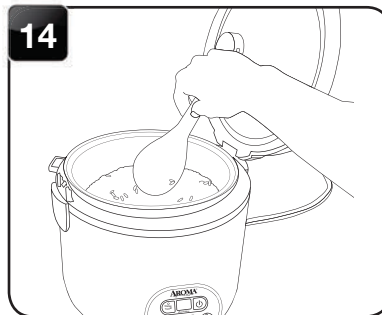

For best results, stir the rice with the serving spatula to distribute any remaining moisture.

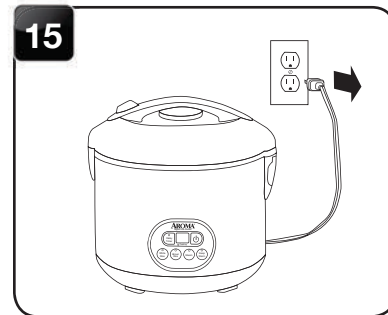

When finished serving rice, turn the rice cooker off by pressing the POWER button twice and unplug the power cord.



- Rice should not be left in the rice cooker on “Keep Warm” for more than 12 hours.

NOTE

TO STEAM

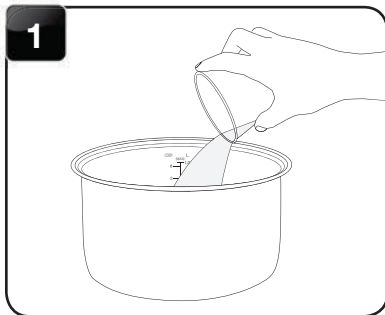

1 Using the provided measuring cup, add 3 cups of water to the inner cooking pot.



2 Place the inner cooking pot into the rice cooker.

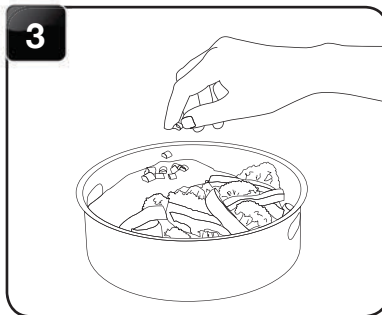

3 Place food to be steamed onto the steam tray.



4 Place the steam tray into the rice cooker.



5 Close the lid securely.

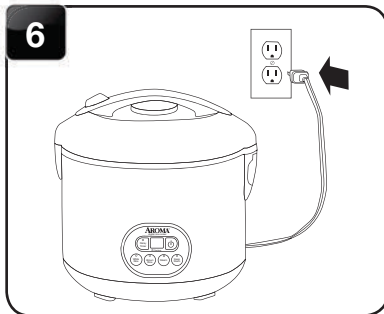

6 Plug the cord into an available outlet.



NOTE

- Before placing the inner cooking pot into the rice cooker, check that it is dry and free of debris. Adding the inner cooking pot when wet may damage the rice cooker.



HELPFUL HINTS

- Smaller foods may be placed on a heat-proof dish and then placed onto the steam tray. Parchment paper or aluminum foil may be used as well. Place the paper/foil in the center of the steam tray and ensure it does not create a seal along the bottom of the steam tray. For best results, it is recommended to puncture small holes in the paper/foil.
- For suggested steaming times and water amounts, see the meat and vegetable steaming tables on **page 15**.



TO STEAM (CONT.)

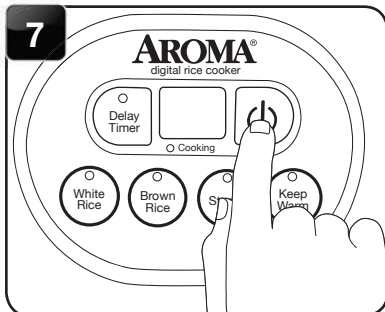

Press the **POWER** button to turn the rice cooker on.

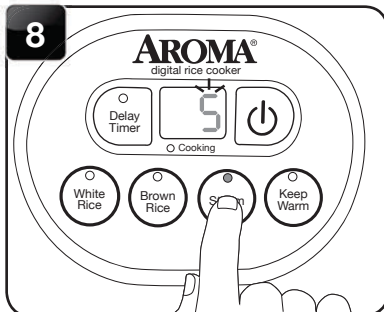

Press the **STEAM** button. The digital display will show a flashing 5 to represent five minutes of steam time.

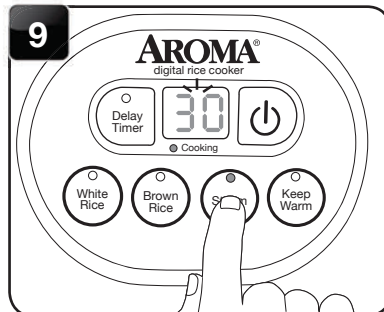

Each press of the **STEAM** button will increase steaming time by one minute, up to 30 minutes. After 30 minutes, it will cycle back to five minutes.

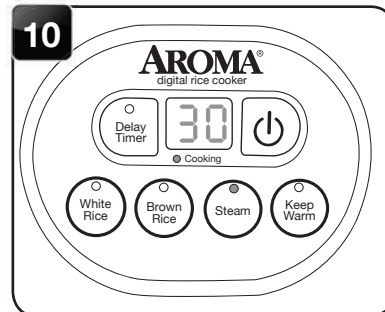

Once cooking time is selected, the rice cooker will beep and the digital display will stop flashing to indicate it is setting to the displayed time and steaming has begun.

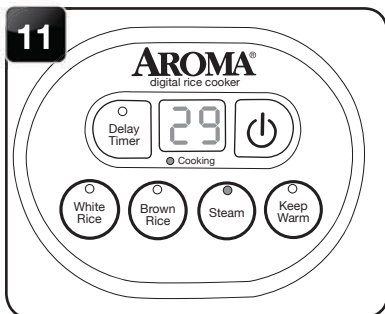

When the water reaches a boil, the digital display will count down in one minute increments from the selected time.

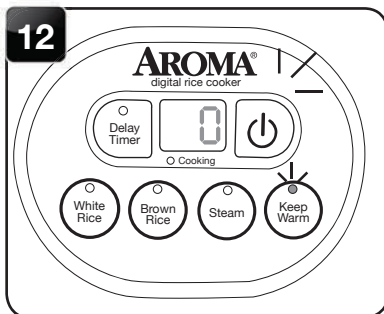

Once the selected time has passed, the rice cooker will beep and switch to its "Keep Warm" setting. The digital display will show the number of hours the rice cooker has been on "Keep Warm," beginning with "0."

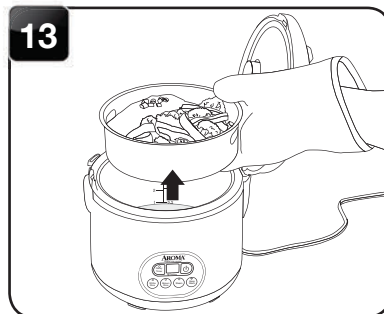

Check steamed food for doneness. If finished steaming, carefully remove the steam tray. It will be hot.

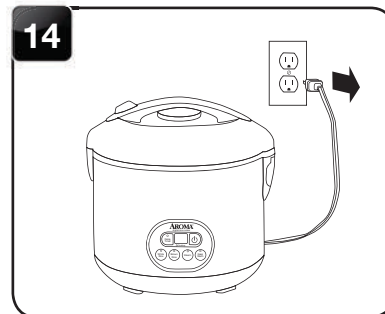

Press the **POWER** button twice to turn off the rice cooker and unplug the power cord.



TO STEAM FOOD & SIMULTANEOUSLY COOK RICE

Follow steps 1 to 9 of “To Cook Rice” beginning on page 5.

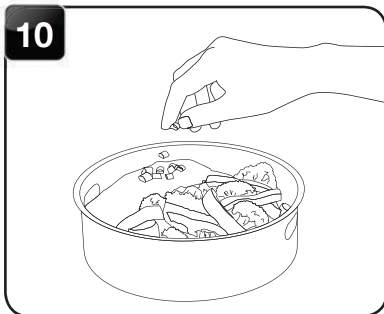

10
Place food to be steamed onto the steam tray.



11
Using caution to avoid escaping steam, open the lid.



12
Place steam tray into the rice cooker.



13
Close the lid securely.



NOTE

- Do not attempt to cook more than **4 cups (uncooked)** of rice if steaming and cooking rice simultaneously.
- It is possible to steam at any point during the rice cooking cycle. However, it is recommended that you steam during the end of the cycle so that steamed food does not grow cold or become soggy before the rice is ready.



HELPFUL HINTS

- The countdown feature is an excellent way to plan when to add the steam tray to ensure rice and steamed food finish cooking at the same time.
- Refer to the steaming tables for meats and vegetables on **page 15** for hints and approximate steaming times. See the “Rice/Water Measurement Table” included on **page 8** for approximate rice cooking times.



TO STEAM FOOD & SIMULTANEOUSLY COOK RICE (CONT.)



14 Using caution, open the lid to check food for doneness. If finished, remove steam tray. It will be hot.



15 Allow rice cooker to continue cooking rice.

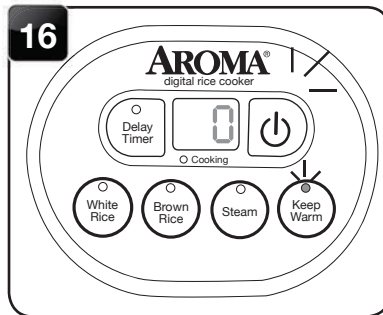

16 Once rice is finished, the rice cooker will beep and automatically switch to its "Keep Warm" setting. The digital display will show the number of hours the rice cooker has been on "Keep Warm," beginning with "0."

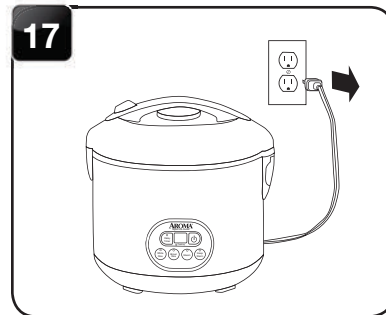

17 When finished serving rice, turn the rice cooker off by pressing the POWER button twice and unplug the power cord.



NOTE

- Rice should not be left in the rice cooker on "Keep Warm" for more than 12 hours.



STEAMING TABLES

When steaming, Aroma® recommends using 3 cups of water with the provided measuring cup.

Meat Steaming Table

MEAT	STEAMING TIME	SAFE INTERNAL TEMPERATURE
Fish	25 Min.	140°
Chicken	30 Min.	165°
Pork	30 Min.	160°
Beef	Medium = 25 Min. Medium-Well = 30 Min. Well = 33 Min.	160°

Vegetable Steaming Table

VEGETABLE	STEAMING TIME
Asparagus	9-11 Minutes
Broccoli	6-8 Minutes
Cabbage	5-7 Minutes
Carrots	11-13 Minutes
Cauliflower	7-9 Minutes
Corn on the Cob	12-16 Minutes
Green Beans	9-11 Minutes
Peas	4-6 Minutes
Potatoes	28-33 Minutes
Spinach	2-4 Minutes
Squash	9-11 Minutes
Zucchini	9-11 Minutes



HELPFUL HINTS

- Since most vegetables only absorb a small amount of water, **there is no need to increase the amount of water with a larger serving of vegetables.**
- Steaming times may vary depending on the cut of meat being used.
- To ensure meat tastes its best, and to prevent possible illness, check that meat is completely cooked prior to serving. If it is not, simply place more water in the inner cooking pot and repeat the cooking process until the meat is adequately cooked.



NOTE

- Altitude, humidity and outside temperature will affect cooking times.
- These steaming charts are for reference only. Actual cooking times may vary.



TO COOK SOUP, CHILI OR STEW

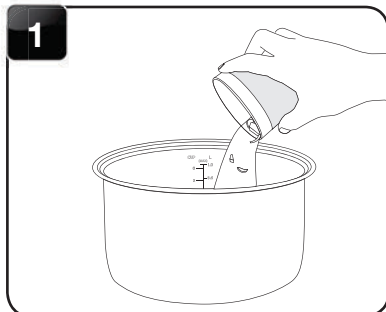

1
Add ingredients to the inner cooking pot.



2
Place the inner cooking pot into the rice cooker.



3
Close the lid securely.

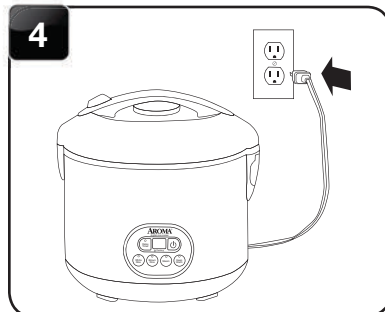

4
Plug the cord into an available outlet.



CAUTION

- The rice cooker will not switch to its “Keep Warm” setting until all liquid is boiled away. Follow the recipe carefully and do not leave the rice cooker unattended.



TO COOK SOUP, CHILI OR STEW (CONT.)

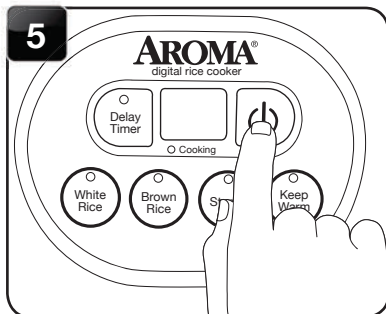

Press the **POWER** button to turn the rice cooker on.

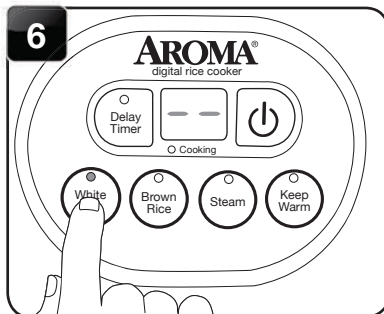

Press the **WHITE RICE** button to begin cooking.

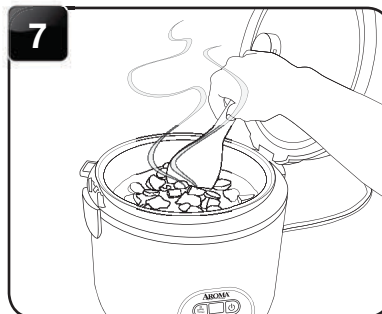

Using caution to avoid escaping steam, open the lid and stir occasionally with a long-handled wooden spoon.

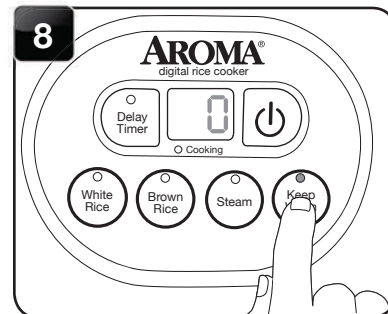

Once cooking is complete, press the **KEEP WARM** button to switch the rice cooker to its “Keep Warm” setting.

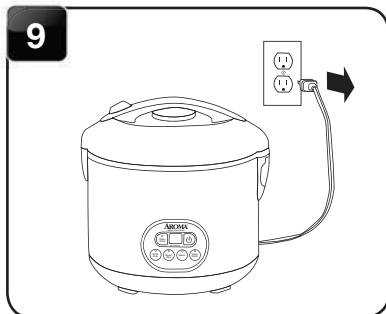

When finished serving, turn the rice cooker off by pressing the **POWER** button twice and unplug the power cord.



NOTE

- Food should not be left in the rice cooker on its “Keep Warm” setting for more than 12 hours.



HOW TO CLEAN

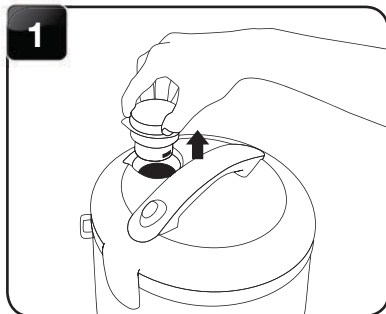

Remove the steam vent.

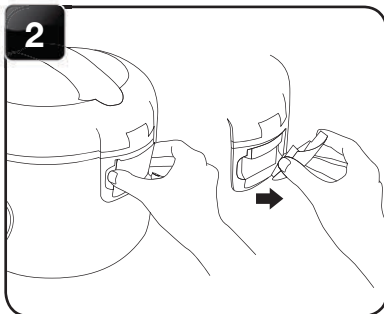

Remove the condensation collector.

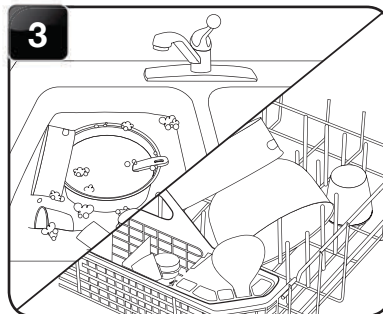

Soak inner cooking pot and all accessories or wash them in the dishwasher.



Wipe rice cooker body clean with a damp cloth.

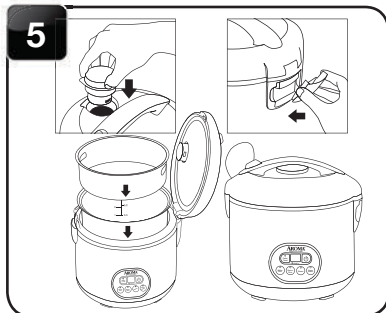

Thoroughly dry rice cooker body and all accessories. Reassemble for next use.



NOTE

- Do not use harsh abrasive cleaners, scouring pads or products that are not considered safe to use on nonstick coatings.
- If washing in the dishwasher, a slight discoloration to the inner pot and accessories may occur. This is cosmetic only and will not affect performance.
- Any other servicing should be performed by Aroma® Housewares. Contact Aroma® customer service at 1-800-276-6286, Monday to Friday 8:30AM-4:30PM PST.



TROUBLESHOOTING

Because rice varieties may vary in their make-up, results may differ. Below are some troubleshooting tips to help you achieve the desired consistency.

<p>Rice is too dry/hard after cooking.</p>	<p>If your rice is dry or hard/chewy when the rice cooker switches to “Keep-Warm” mode, additional water and cooking time will soften the rice. Depending on how dry your rice is, add ½ to 1 cup of water and stir through. Close the lid and press the WHITE RICE button. When rice cooker switches to “Keep-Warm” mode, remove the lid and stir the rice to check the consistency. Repeat as necessary until rice is soft and moist.</p>
<p>Rice is too moist/soggy after cooking.</p>	<p>If your rice is still too moist or soggy when the rice cooker switches to “Keep-Warm” mode, use the serving spatula to stir the rice. This will redistribute the bottom (moistest) part of the rice as well as release excess moisture. Close the lid and allow to remain on “Keep-Warm” mode for 10-30 minutes as needed, removing the lid and stirring periodically to release excess moisture.</p>
<p>The bottom layer of rice is browned/ caramelized.</p>	<p>The bottom layer of cooked rice may become slightly browned and/or caramelized during cooking. To reduce browning, rice should be rinsed before cooking to remove any excess starch. Stirring rice once it switches to “Keep-Warm” will also help to reduce browning/caramelizing.</p>



ABOUT RICE

Courtesy of the USA Rice Federation

Rice is the perfect foundation for today's healthier eating. It is a nutrient-dense complex carbohydrate that supplies energy, fiber, essential vitamins and minerals and beneficial antioxidants. Rice combines well with other healthy foods such as vegetables, fruits, meat, seafood, poultry, beans and soy foods.

Nearly 88% of rice consumed in the U.S. is grown in the U.S. Arkansas, California, Louisiana, Texas, Mississippi and Missouri produce high-quality varieties of short, medium and long grain rice as well as specialty rices including jasmine, basmati, arborio, red aromatic and black japonica, among others.

There are many different varieties of rice available in the market. Your Aroma® Rice Cooker can cook any type perfectly every time. The following are the commonly available varieties of rice and their characteristics:

Long Grain Rice

This rice has a long, slender kernel three to four times longer than its width. Due to its starch composition, cooked grains are more separate, light and fluffy compared to medium or short grain rice. The majority of white rice is enriched to restore nutrients lost during processing. Great for entrees and side dishes— rice bowls, stir-fries, salads and pilafs.

Medium Grain Rice

When compared to long grain rice, medium grain rice has a shorter, wider kernel that is two to three times longer than its width. Cooked grains are more moist and tender than long grain, and have a greater tendency to cling together. Great for entrees, sushi, risotto and rice puddings.

Short Grain Rice

Short grain rice has a short, plump, almost round kernel. Cooked grains are soft and cling together, yet remain separate and are somewhat chewy, with a slight springiness to the bite. Great for sushi, Asian dishes and desserts.

Brown Rice

Brown rice is a 100% whole grain food that fits the U.S. Dietary Guidelines for Americans recommendation to increase daily intake of whole grains. Brown rice contains the nutrient-dense bran and inner germ layer where many beneficial compounds are found. Brown rice is available in short, medium and long grain varieties and can be used interchangeably with enriched white rice.

Wild Rice

Wild rice is an aquatic grass grown in Minnesota and California and is a frequent addition to long grain rice pilafs and rice mixes. Its unique flavor, texture and rich dark color provide a delicious accent to rice dishes. Wild rice also makes a wonderful stuffing for poultry when cooked with broth and mixed with your favorite dried fruits.

For recipes and rice information visit the USA Rice Federation online at www.usarice.com/consumer.





ABOUT RICE (CONT.)

Courtesy of the USA Rice Federation

Did You Know?

- Rice is the primary dietary staple for more than half of the world's population.
- U.S. grown rice is the standard for excellence and accounts for nearly 88% of the rice consumed in America. It is grown and harvested by local farmers in five south-central states and California.
- Rice contains no sodium, cholesterol, trans fats or gluten, and has only a trace of fat. One half-cup of rice contains about 100 calories.
- Research shows that people who eat rice have healthier diets than non-rice eaters and eat more like the U.S. Dietary Guidelines for Americans recommendations.
- Whole grains like brown rice help reduce the risk of chronic diseases such as heart disease, diabetes and certain cancers, and aid in weight management.
- Brown rice is a 100% whole grain. One cup of whole grain brown rice provides two of the three recommended daily servings of whole grains.
- Eating rice triggers the production of serotonin in the brain, a chemical that helps regulate and improve mood.
- September is National Rice Month - promoting awareness of the versatility and the value of U.S. grown rice.

For recipes and rice information visit the USA Rice Federation online at www.usarice.com/consumer.





RECIPES

Aroma's Favorite Jambalaya

Ingredients

1 lb	spicy smoked sausage
1 lb.	shrimp, peeled and deveined
2 cups	cooked chicken, shredded
1½ cups	rice
4 cups	chicken broth
1	4-oz. can diced green chiles
2 tbsp.	Creole seasoning

Cut the smoked sausage in half, lengthwise, then into ¼" half circles. Add all ingredients to the inner cooking pot and mix well. Place inner cooking pot in the rice cooker and close the lid. Press the POWER button to turn on the rice cooker. Press WHITE RICE. The rice cooker will automatically switch to "Keep Warm" mode once the meal is ready. Serves 4.

Game Day Chili Cheese Dip

Ingredients

1	small onion, chopped
2 tsp.	vegetable oil
1	clove garlic, minced
2	15-oz. cans prepared chili without beans
1 cup	prepared medium salsa
½ cup	black olives, sliced
3 ounces	low-fat cream cheese, cubed
3 ounces	cheddar cheese, grated
-	Tortilla chips, for dipping

Press the POWER button to turn on the rice cooker. Place the onion, oil and garlic in the inner cooking pot and sauté for 3 minutes. Use a large wooden spoon to gently stir as the onion and garlic cook. Add the chili, salsa, olives, cream cheese and cheddar cheese. Stir to combine all of the ingredients, close the lid and press the WHITE RICE button. Cook for 4 minutes. Carefully open the lid, keeping hands and face away to avoid steam burns, and stir the dip. Cook again for 3 minutes. Open the lid and stir again. Continue cooking until the dip is warm throughout and the cheeses are melted. When done, serve in a large bowl and use the tortilla chips for dipping. Serves 4.



Green Chili Chicken & Rice

Ingredients

- | | |
|---------|---|
| 1½ cups | rice |
| 3 cups | chicken broth |
| 2 tbsp. | diced minced onion |
| ½ tsp. | salt |
| 1 | 10-oz. can chicken breast chunks, with liquid |
| 1 | 4-oz. can diced green chiles, with liquid |

Place all ingredients in the inner cooking pot and stir. Place inner cooking pot into the rice cooker, cover. Press the POWER button to turn on the rice cooker. Press the WHITE RICE button. Allow to cook until rice cooker switches to “Keep Warm” mode. Add additional salt to taste, if needed. Stir and serve immediately as a main course. Serves 4.

San Antonio Rice

Ingredients

- | | |
|----------------|------------------------------------|
| 1 cup | rice |
| 1 jar (12 oz.) | fresh salsa, mild or hot |
| 1 tbsp. | vegetable oil |
| 1 cup | fresh or canned corn kernels |
| ½ tsp. | ground cumin |
| ½ tsp. | salt |
| 1¼ cups | water |
| - | Fresh ground pepper, to taste |
| - | Fresh minced cilantro, for garnish |

Add all ingredients except cilantro to the inner cooking pot, stir. Close the lid and press the POWER button to turn on the rice cooker. Press the WHITE RICE button. When rice cooker switches to “Keep Warm” mode, open the cooker, quickly stir and re-cover. Allow to stand for 8-10 minutes before serving. Spoon onto a serving dish, garnish with fresh cilantro and serve. Makes a flavorful supper or side dish for grilled chicken or fish. Serves 3-4.



WARRANTY

LIMITED WARRANTY

Aroma Housewares Company warrants this product free from defects in material and workmanship for one year from provable date of purchase in the United States.

Within this warranty period, Aroma Housewares Company will repair or replace, at its option, defective parts at no charge, provided the product is returned, freight prepaid with proof of purchase and U.S. \$18.00 for shipping and handling charges payable to Aroma Housewares Company. Before returning an item, please call the toll free number below for a return authorization number. Allow 2-4 weeks for return shipping.

This warranty does not cover improper installation, misuse, abuse or neglect on the part of the owner. Warranty is also invalid in any case that the product is taken apart or serviced by an unauthorized service station.

This warranty gives you specific legal rights, which may vary from state to state, and does not cover areas outside the United States.

AROMA HOUSEWARES COMPANY
6469 Flanders Drive
San Diego, California 92121
1-800-276-6286
M-F, 8:30 AM - 4:30 PM, Pacific Time
Website: www.AromaCo.com

SERVICE & SUPPORT

In the event of a warranty claim, or if service is required for this product, please contact Aroma® customer service toll-free at:

1-800-276-6286
M-F, 8:30AM-4:30PM, Pacific Time

Or we can be reached online at CustomerService@AromaCo.com.

For your records, we recommend stapling your sales receipt to this page along with a written record of the following:

Date of Purchase: _____

Place of Purchase: _____



NOTE

- Proof of purchase is required for all warranty claims.